



# **PARTS CATALOGUE**

## *WaveRunner VX700* **VX700-G** (F1V3/6AEC/6AE1)

---

VX700-G  
PARTS CATALOGUE  
©2007 by Yamaha Motor Co., Ltd.  
1st edition, July 2007  
All rights reserved.  
Any reprinting or unauthorized use  
without the written permission of  
Yamaha Motor Co., Ltd.  
is expressly prohibited.  
Printed in Japan.

**A3**

# FOREWORD

This Parts Catalogue is related to the parts for the model(s) on the cover page. When you are ordering replacement parts, please refer to this Parts Catalogue and quote both part numbers and part names correctly.

1. Modifications or additions which have been made after the issue of the Parts Catalogue will be announced in the Parts News.

It is advisable that you make the necessary corrections to the Parts Catalogue according to the Parts News.

2. Abbreviations

The following abbreviations are used in this Parts Catalogue.

“UR” Use specified parts number.

“UN” Use as many as needed.

“AP” Alternate Parts

“LM” Locally Made (Parts need to be ordered locally)

“F#” Frame No. (Applicable machine No.)

“O/S” Over Size

3. The number of components for assembly

- Parts, which are to be supplied in an assembly, are listed with a dot (.) in front of the part name as shown below.
- The numeral appearing to the right of each component part indicates the quantity of parts for each assembly unit.

PART NO.	DESCRIPTION	Q'TY	REMARKS
2F5-83310-60	FRONT FLASHER LIGHT ASSY	2	
115-83311-60	.BULB (6V-18W)	1	

4. Applicable colours of graphics are represented in the “REMARKS” as shown below.

PART NO.	DESCRIPTION	Q'TY	REMARKS
2N4-24110-00-X5	FUEL TANK COMP.	2	MXR
3J1-24240-10	.GRAPHIC, FUEL TANK	1	FOR MXR

5. Note that the illustrations for reference in finding parts numbers are not to be used for assembling. When assembling, please use the applicable service manual.

6. The asterisk (\*) before a reference number indicates modified items after the first edition.

# FOREWORD

7. Applicable Serial No.

Engine Serial No.

Hull Serial No.

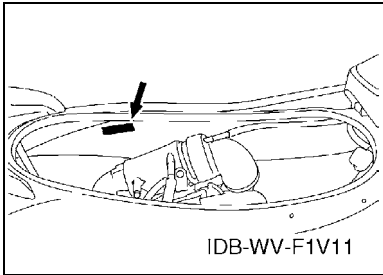
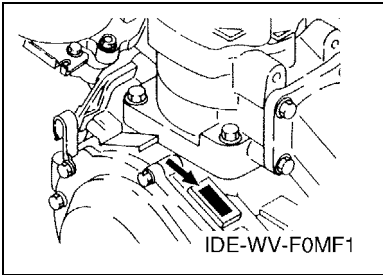

8. Applicable Colour Code (The (\*) mark shows Model colour.)

Abbreviation	Colour Name	Colour Code
NMC(*)	GRAY METALLIC C	008S
PURW(*)	PURE WHITE	0240
SS4(*)	BLACK SOLID 4	008P
RM4	RED METALLIC 4	0923
YB	YAMAHA BLACK	0033

9. Quantity Column Information

Column No.	Name Of Q'ty Column	Destination
1	OTH	OTHERS

10. Applicable Starting Serial No.

Engine Serial No.

Serial No.	Name Of Q'ty Column	Model Code
6AE-1003401	OTH	6AEC

Hull Serial No.

Serial No.	Name Of Q'ty Column	Model Code
F1V-803501	OTH	F1V3

# CONTENTS

CYLINDER & CRANKCASE .....	B2
CRANKSHAFT & PISTON .....	B4
INTAKE .....	B6
CARBURETOR .....	B8
OIL PUMP .....	B10
EXHAUST 1 .....	B11
FUEL .....	B14
JET UNIT 1 .....	B15
JET UNIT 2 .....	C3
GENERATOR .....	C4
STARTING MOTOR .....	C5
ELECTRICAL 1 .....	C6
ELECTRICAL 2 .....	C8
ENGINE HATCH 1 .....	C10
ENGINE HATCH 2 .....	C11
HULL & DECK .....	C12
GUNWALE & MAT .....	C14
VENTILATION .....	C15
SEAT & UNDER LOCKER .....	D2
OIL TANK .....	D3
FUEL TANK .....	D4
EXHAUST 2 .....	D6
CONTROL CABLE .....	D7
STEERING 1 .....	D8
STEERING 2 .....	D10
GRAPHICS .....	D11
IMPORTANT LABELS .....	D12
REPAIR KIT 1 .....	D13
REPAIR KIT 2 .....	D14

## INDEX

NUMERICAL INDEX .....	M1
-----------------------	----

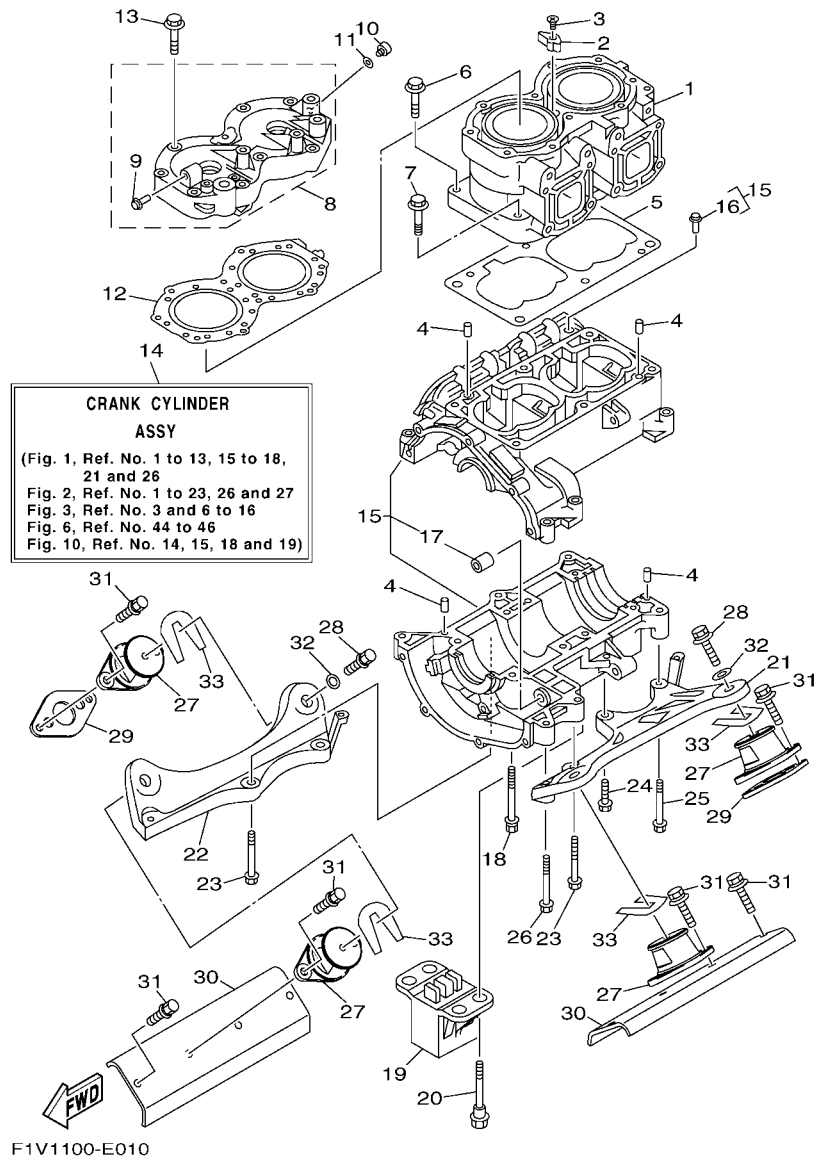

F1V1100-E010

FIG. 1 CYLINDER & CRANKCASE

REF. NO.	PART NO.	DESCRIPTION	QTY				REMARKS
1	62T-11311-00-8S	CYLINDER 1	1				
2	6E5-11325-00	ANODE	1				
3	98780-04015	SCREW, FLAT HEAD	1				
4	93606-12019	PIN, DOWEL	4				
5	6M6-11351-A2	GASKET, CYLINDER	1				
6	90119-10M56	BOLT, WITH WASHER	4				
7	90119-10M07	BOLT, WITH WASHER	2				
8	62T-11111-00-8S	HEAD, CYLINDER 1	1				
9	6K8-51129-00	.NIPPLE	1				
10	90340-08M04	PLUG, STRAIGHT SCREW	1				
11	90430-08020	GASKET	1				
12	62T-11181-01	GASKET, CYLINDER HEAD 1	1				
13	90119-08M96	BOLT, WITH WASHER	10				
14	62T-W0090-03-8S	CRANK CYLINDER ASSY	1				
15	62T-15100-00-8S	CRANKCASE ASSY	1				
16	62T-14251-10	.NIPPLE	1				
17	90380-12M29	.BUSH, SOLID	1				
18	90119-08M55	BOLT, WITH WASHER	4				
19	61L-44532-00	STOPPER, UPPER MOUNT	1				
20	90109-08M56	BOLT	4				
21	6R7-21415-01-94	BRACKET, FRONT UPPER 1	1				
22	6R7-21425-01-94	BRACKET, REAR UPPER 1	1				
23	90119-10M02	BOLT, WITH WASHER	4				
24	90119-10M00	BOLT, WITH WASHER	1				
25	90119-10M03	BOLT, WITH WASHER	1				
26	90119-10M01	BOLT, WITH WASHER	1				
27	62E-44517-A1-8P	MOUNT RUBBER	4				



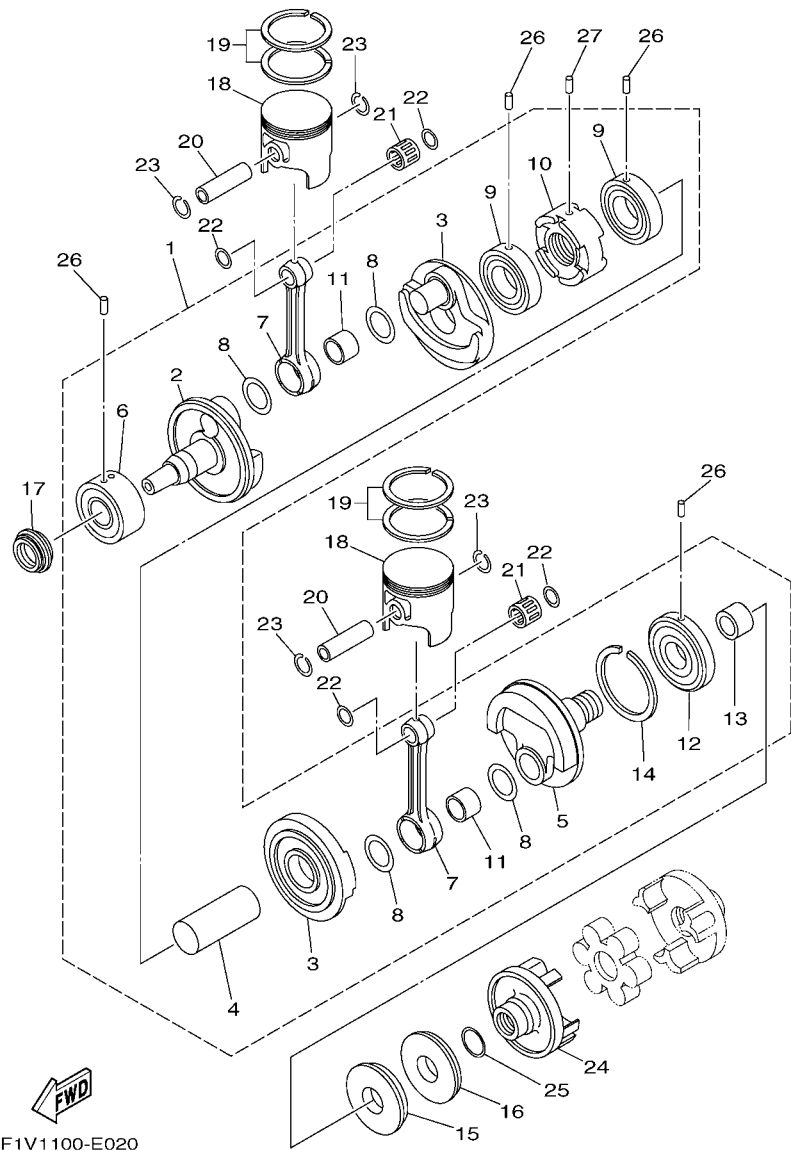

F1V1100-E020

FIG. 2 CRANKSHAFT & PISTON

REF. NO.	PART NO.	DESCRIPTION	QTY				REMARKS
1	62T-11400-02	CRANKSHAFT ASSY	1				
2	6M6-11412-00	.CRANK 1	1				
3	6M6-11422-00	.CRANK 2	2				
4	6M6-11431-00	.CRANK 3	1				
5	6M6-11442-01	.CRANK 4	1				
6	93305-30601	.BEARING	1				
7	62T-11651-00	.ROD, CONNECTING	2				
8	82M-11685-00	.WASHER, CRANK PIN	4				
9	93306-207U2	.BEARING	2				
10	82M-11515-00	.SEAL, LABYRINTH 1	1				
11	93310-525U3	.BEARING	2				
12	93306-307U3	.BEARING	1				
13	62T-45526-00	.COLLAR, DRIVE SHAFT	1				
14	93440-80023	.CIRCLIP	1				
15	93102-36M33	OIL SEAL	1				
16	93101-36M46	OIL SEAL	1				
17	93103-32M01	OIL SEAL	1				
18	62T-11631-02-92	PISTON (STD)	2				
	62T-11635-02	PISTON (0.25MM O/S)	2				AP
	62T-11636-02	PISTON (0.50MM O/S)	2				AP
19	61X-11603-01	PISTON RING SET (STD)	2				
	61X-11604-01	PISTON RING SET (0.25MM O/S)	2				AP
	61X-11605-01	PISTON RING SET (0.50MM O/S)	2				AP
20	62T-11633-00	PIN, PISTON	2				
21	93310-320U2	BEARING	2				
22	90201-20M04	WASHER, PLATE	4				
23	93450-21053	CIRCLIP	4				





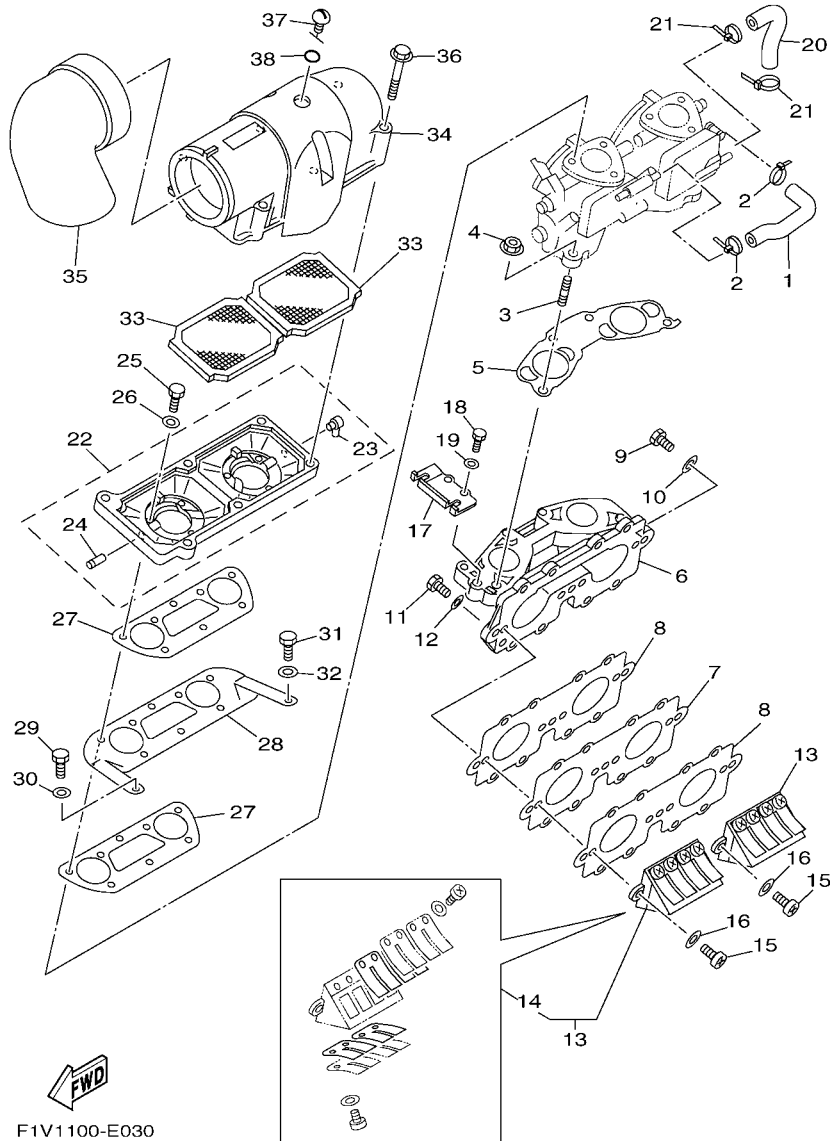

F1V1100-E030

FIG. 3 INTAKE

REF. NO.	PART NO.	DESCRIPTION	QTY				REMARKS
1	62T-24313-01	PIPE 3	1				
2	90465-11M10	CLAMP	2				
3	90116-08M60	BOLT, STUD	4				
4	90179-08M15	NUT	4				
5	62T-13556-00	GASKET, MANIFOLD	1				
6	62T-13555-00-94	MANIFOLD, INTAKE	1				
7	62T-13624-00	PLATE, REED VALVE	1				
8	62T-13566-00	GASKET	2				
9	97013-06035	BOLT	3				
10	92903-06600	WASHER, PLATE	3				
11	97013-06025	BOLT	8				
12	92903-06600	WASHER, PLATE	8				
13	62T-13610-00	REED VALVE ASSY	2				
14	62T-W0004-00	.REED SET	1				
15	97880-05016	SCREW, PAN HEAD	4				
16	92990-05600	WASHER, PLATE	4				
17	62T-14527-02	PLATE	1				
18	97013-06016	BOLT	2				
19	92903-06600	WASHER, PLATE	2				
20	62T-24314-01	PIPE 4	1				
21	90465-11M10	CLAMP	2				
22	62T-14284-01-8S	COVER, CARBURETOR 2	1				
23	6E5-11372-01	.NIPPLE, HOSE	1				
24	6H1-14485-00	.PIPE, JOINT	1				
25	97013-06020	BOLT	6				
26	92903-06600	WASHER, PLATE	6				
27	62T-13674-00	GASKET, AIR COOLER COVER 1	2				

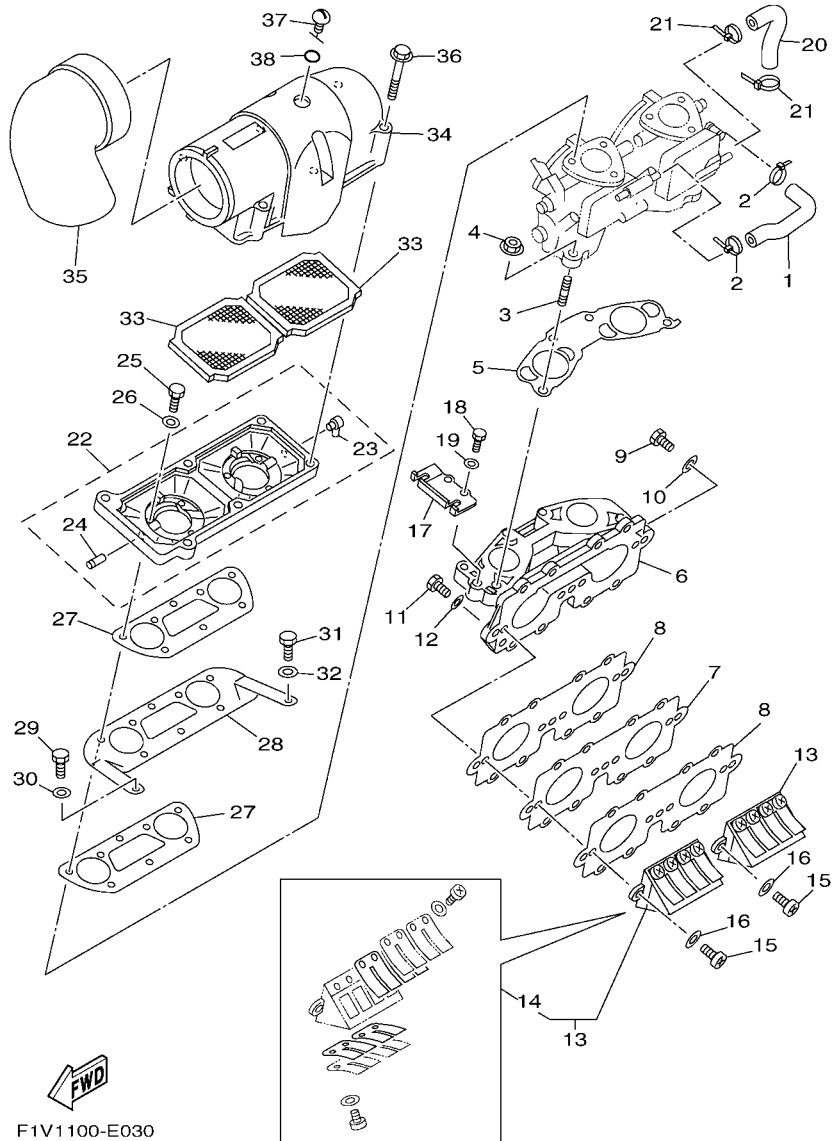

F1V1100-E030

FIG. 3 INTAKE

REF. NO.	PART NO.	DESCRIPTION	QTY				REMARKS
28	62T-14255-00	PLATE	1				
29	97013-06012	BOLT	1				
30	92903-06600	WASHER, PLATE	1				
31	90109-06M66	BOLT	1				
32	90201-06M31	WASHER, PLATE	1				
33	62T-14451-00	ELEMENT, AIR CLEANER	2				
34	62T-14283-01	COVER, CARBURETOR 1	1				
35	62T-14419-00	PIPE	1				
36	90119-05M02	BOLT, WITH WASHER	6				
37	62T-14435-00	GROMMET	1				
38	93210-13M63	O-RING	1				

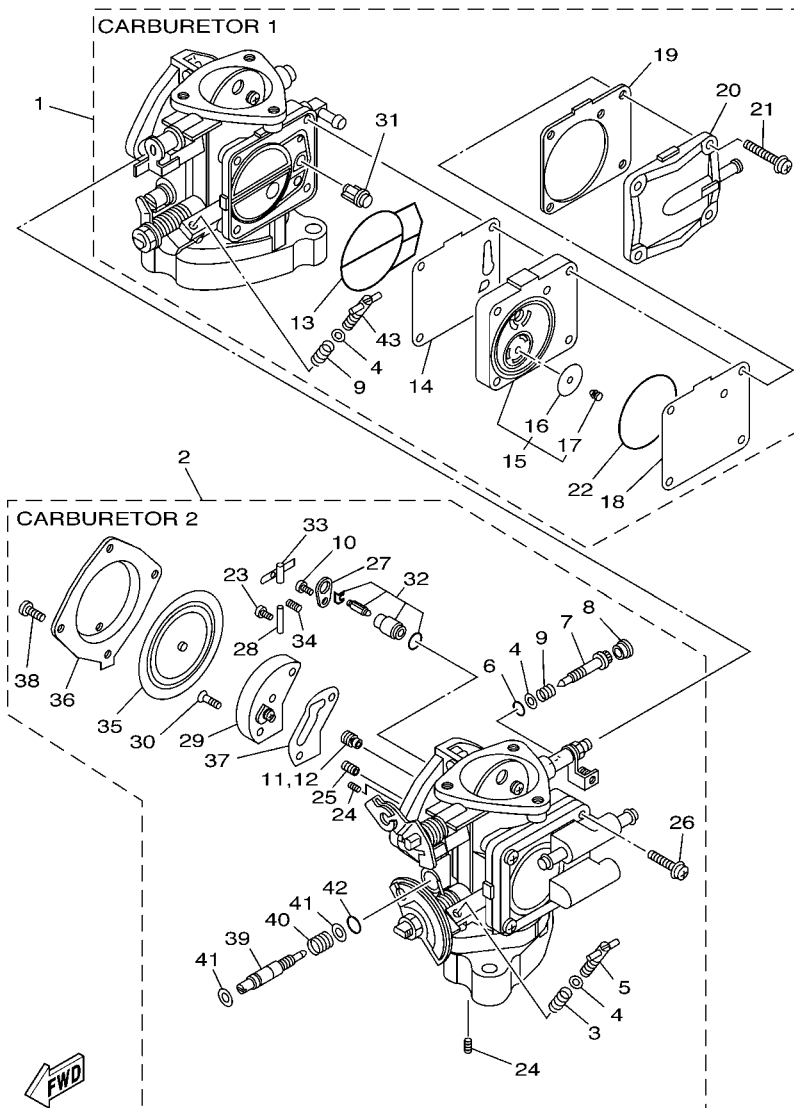

FOM5100-0040

FIG. 4 CARBURETOR

REF. NO.	PART NO.	DESCRIPTION	QTY			REMARKS
1	62T-14301-03	CARBURETOR ASSY 1	1			
2	62T-14302-03	CARBURETOR ASSY 2	1			
3	47X-14133-00	.SPRING, THROTTLE STOP	1			CARBURETOR 2
4	812-14235-00	.WASHER, NEEDLE	4			
5	6M6-14521-00	.SCREW, ADJUST	1			CARBURETOR 2
6	812-14147-00	.O-RING	2			
7	6K8-14946-10	.METERING NEEDLE	2			
8	6K8-14471-10	.CAP, CARBURETOR	2			
9	3KW-14932-00	.SPRING, THROTTLE 2	3			
10	6M6-14503-00	.SCREW	2			
11	3G2-14231-26	.JET, MAIN (#130)	1			CARBURETOR 1
12	3G2-14231-24	.JET, MAIN (#120)	1			CARBURETOR 2
13	6K8-14564-00	.O-RING	2			
14	6K8-24411-20	.DIAPHRAGM	1			CARBURETOR 1
15	6M6-24413-01	.BODY 2	1			CARBURETOR 1
16	65U-24421-00	..VALVE, CHECK	2			CARBURETOR 1
17	65U-24492-00	..BUSH, FUEL PUMP	2			CARBURETOR 1
18	6K8-24421-10	.VALVE, CHECK	1			CARBURETOR 1
19	6K8-24431-20	.GASKET, FUEL PUMP 1	1			CARBURETOR 1
20	6K8-24452-10	.COVER	1			UR CARBURETOR 1
	62T-14293-00	.COVER 1	1			UR CARBURETOR 2
21	97980-05330	.SCREW, WITH WASHER	4			CARBURETOR 1
22	6K8-14563-00	.O-RING	1			CARBURETOR 1
23	6K8-14503-02	.SCREW	2			
24	6K8-14521-10	.SCREW	4			
25	830-1423A-64	.JET, MAIN (# 67.5)	2			
26	98580-05018	.SCREW, PAN HEAD	4			CARBURETOR 2

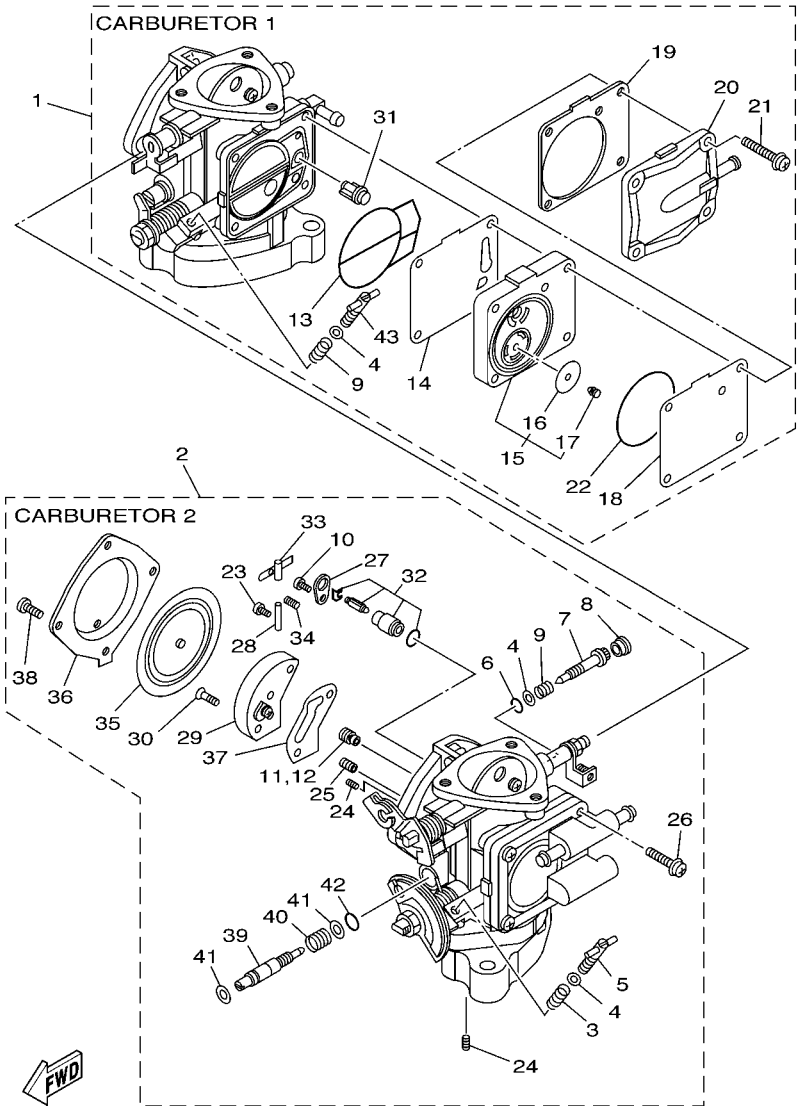

FOM5100-0040

FIG. 4 CARBURETOR

REF. NO.	PART NO.	DESCRIPTION	QTY				REMARKS
27	6K8-14527-11	.PLATE	2				
28	439-14186-00	.PIN, FLOAT	2				
29	6R7-24412-01	.BODY 1	2				
30	6K8-14523-11	.SCREW, STOP	4				
31	6R7-14569-00	.STRAINER	2				
32	61X-14916-16	.NEEDLE	2				
33	6K8-14547-01	.ARM, FLOAT	2				
34	6R7-14253-00	.SPRING	2				
35	6R7-14541-00	.DIAPHRAGM, PUMP	2				
36	6R7-14542-00	.BODY, PUMP 1	2				
37	6K8-14536-11	.GASKET	2				
38	97880-05012	.SCREW, PAN HEAD	8				
39	65U-14923-10	.SCREW, PILOT	2				
40	6K8-14589-00	.SPRING	2				
41	822-14235-00	.WASHER, NEEDLE	4				
42	583-14561-00	.O-RING	2				
43	6K8-14521-00	.SCREW, ADJUST	1				CARBURETOR 1

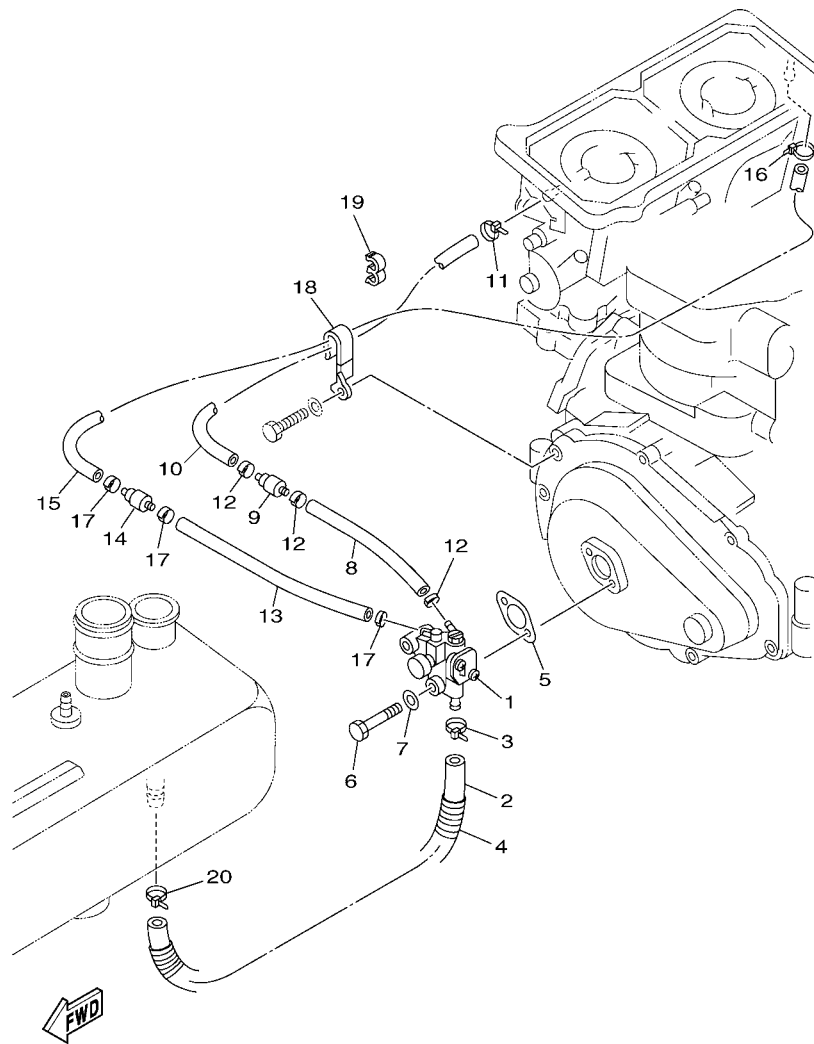

F1V1100-E050

FIG. 5 OIL PUMP

REF. NO.	PART NO.	DESCRIPTION	QTY				REMARKS
1	61X-13200-12	OIL INJECTION PUMP ASSY	1				
2	90445-11037	HOSE (L680)	1				
3	90465-11M10	CLAMP	1				
4	90447-13002	TUBE (L530)	1				
5	6R8-13116-A0	GASKET, PUMP CASE	1				
6	97095-06035	BOLT	2				
7	92995-06600	WASHER	2				
8	90445-07009	HOSE (L85)	1				
9	67X-13183-00	VALVE, CHECK	1				
10	90446-07M18	HOSE (L210)	1				
11	90465-11M10	CLAMP	1				
12	90468-02001	CLIP	3				
13	90445-07008	HOSE (L70)	1				
14	67X-13183-00	VALVE, CHECK	1				
15	90446-07M48	HOSE (L450)	1				
16	90465-11M10	CLAMP	1				
17	90468-02001	CLIP	3				
18	90465-08M69	CLAMP	1				
19	90464-10M38	CLAMP	2				
20	90465-11829	CLAMP	1				

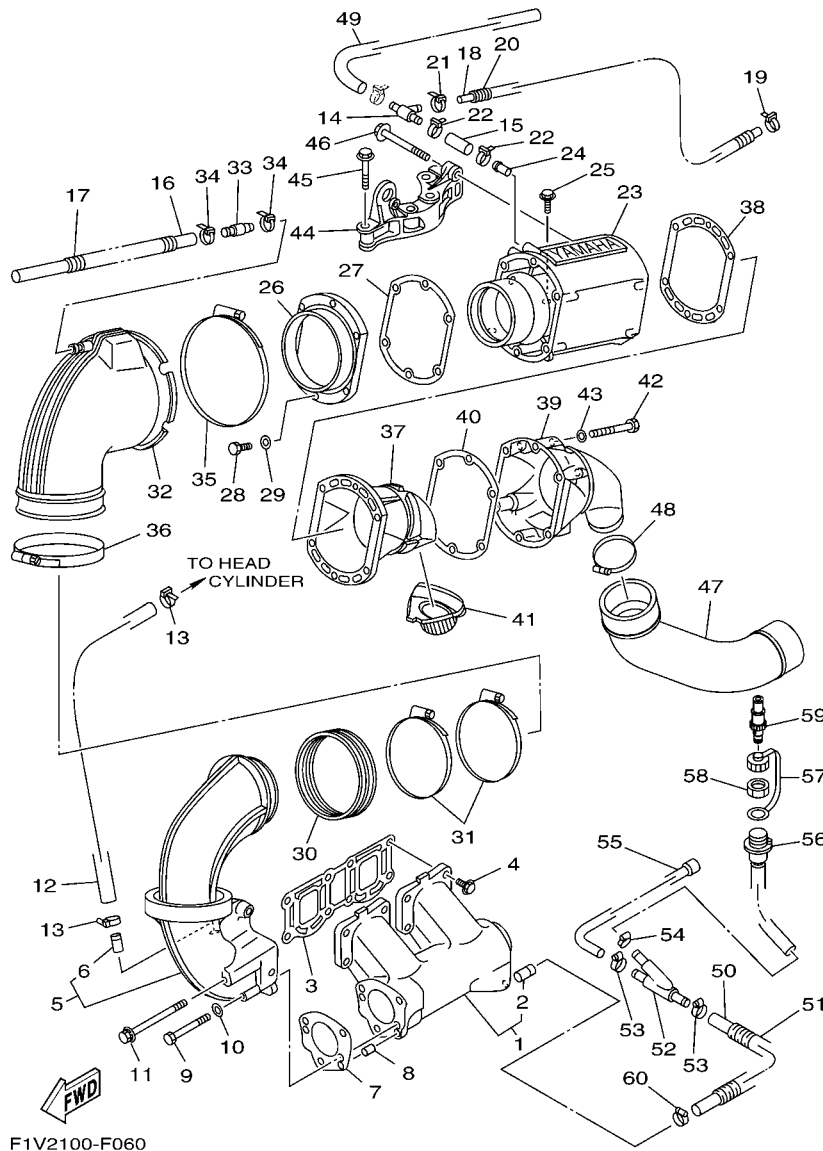

F1V2100-F060

FIG. 6 EXHAUST 1

REF. NO.	PART NO.	DESCRIPTION	QTY				REMARKS
1	62T-14711-10-94	MUFFLER 1	1				
2	6K8-51129-00	.NIPPLE	1				
3	62T-14613-01	GASKET, EXHAUST PIPE	1				
4	90105-10M60	BOLT, FLANGE	8				
5	62T-14712-00-94	RING, JOINT	1				
6	6K8-51129-00	.NIPPLE	1				
7	62T-14749-01	GASKET, MUFFLER DAMPER 2	1				
8	93605-12M21	PIN, DOWEL	2				
9	97013-08075	BOLT	2				
10	92903-08600	WASHER, PLATE	2				
11	90119-08M11	BOLT, WITH WASHER	2				
12	90445-14M24	HOSE (L260)	1				
13	90465-11M10	CLAMP	2				
14	63N-24378-00	PIPE, JOINT 3	1				
15	90445-21010	HOSE (L70)	1				
16	90445-14M33	HOSE (L1150)	1				
17	90447-15003	TUBE	1				
18	90445-14M25	HOSE (L380)	1				
19	90465-11M10	CLAMP	1				
20	90446-20M31	HOSE (L340)	1				
21	90465-11M10	CLAMP	1				
22	90465-11M59	CLAMP	2				
23	62T-14721-00-8S	MUFFLER 2	1				
24	62T-14485-10	PIPE, JOINT	1				
25	90105-10M60	BOLT, FLANGE	2				
26	62T-41113-00-8S	OUTER COVER, EXHAUST	1				
27	62T-41114-01	GASKET, EXHAUST OUTER COVER	1				

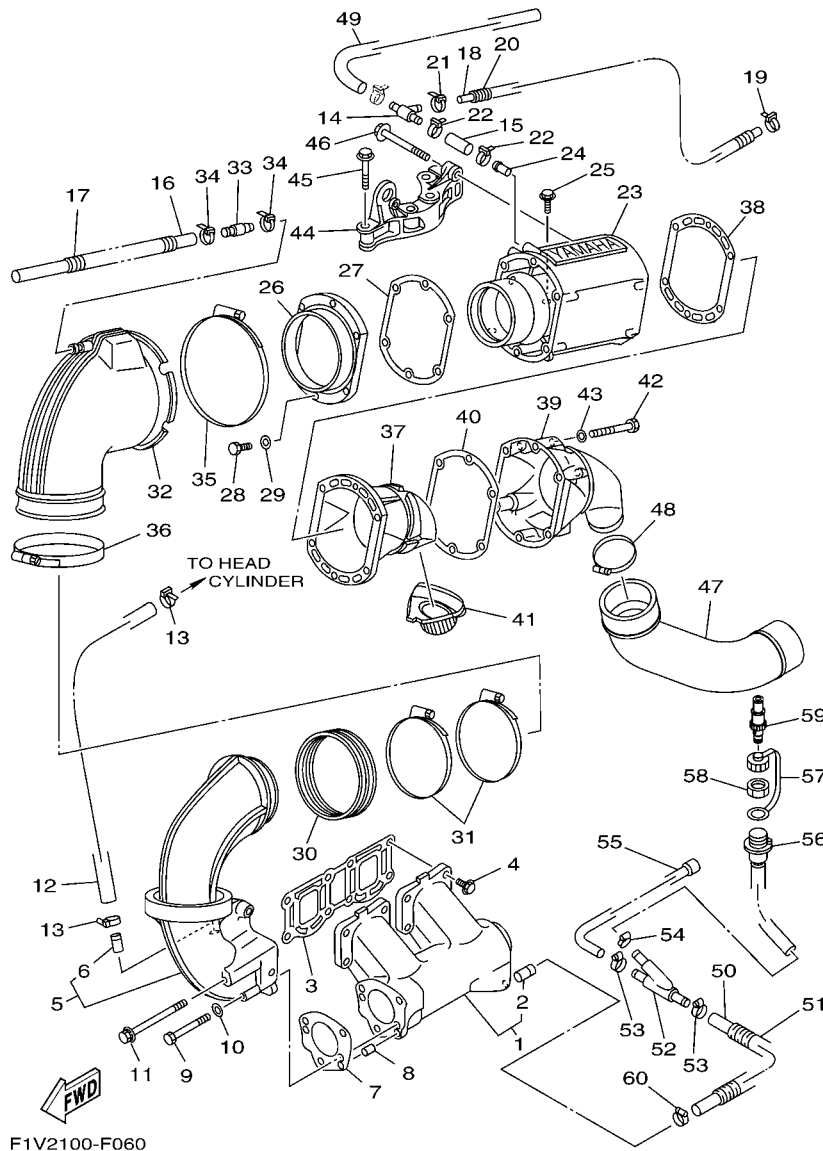

F1V2100-F060

FIG. 6 EXHAUST 1

REF. NO.	PART NO.	DESCRIPTION	QTY				REMARKS
28	97013-06025	BOLT	6				
29	92903-06600	WASHER, PLATE	6				
30	62T-14625-00	JOINT, EXHAUST 2	1				
31	90450-99M06	HOSE CLAMP ASSY	2				
32	62T-14615-01	JOINT, EXHAUST 1	1				
33	6R3-24377-00	PIPE, JOINT 2	1				
34	90465-11M10	CLAMP	2				
35	90450-99M01	HOSE CLAMP ASSY	1				
36	90450-99M02	HOSE CLAMP ASSY	1				
37	62T-41121-00-8S	INNER COVER, EXHAUST	1				
38	62T-41122-00	GASKET, EXHAUST INNER COVER	1				
39	62T-41123-01-8S	OUTER COVER, EXHAUST	1				
40	62T-41124-00	GASKET, EXHAUST OUTER COVER	1				
41	63N-15761-00	SEAL, RUBBER 1	1				
42	97013-06070	BOLT	6				
43	92903-06600	WASHER, PLATE	6				
44	62T-14771-00-94	STAY, MUFFLER 1	1				
45	90119-10M17	BOLT, WITH WASHER	4				
46	90105-10M88	BOLT, FLANGE	2				
47	6AE-14752-00	PIPE, OUTLET	1				
48	90450-70M03	HOSE CLAMP ASSY	1				
49	90445-21009	HOSE (L1030)	1				
50	90445-14M14	HOSE (L330)	1				
51	90446-20M13	HOSE (L260)	1				
52	64X-12581-00	JOINT, HOSE 1	1				
53	90450-14M05	HOSE CLAMP ASSY	2				
54	90450-18M09	HOSE CLAMP ASSY	1				





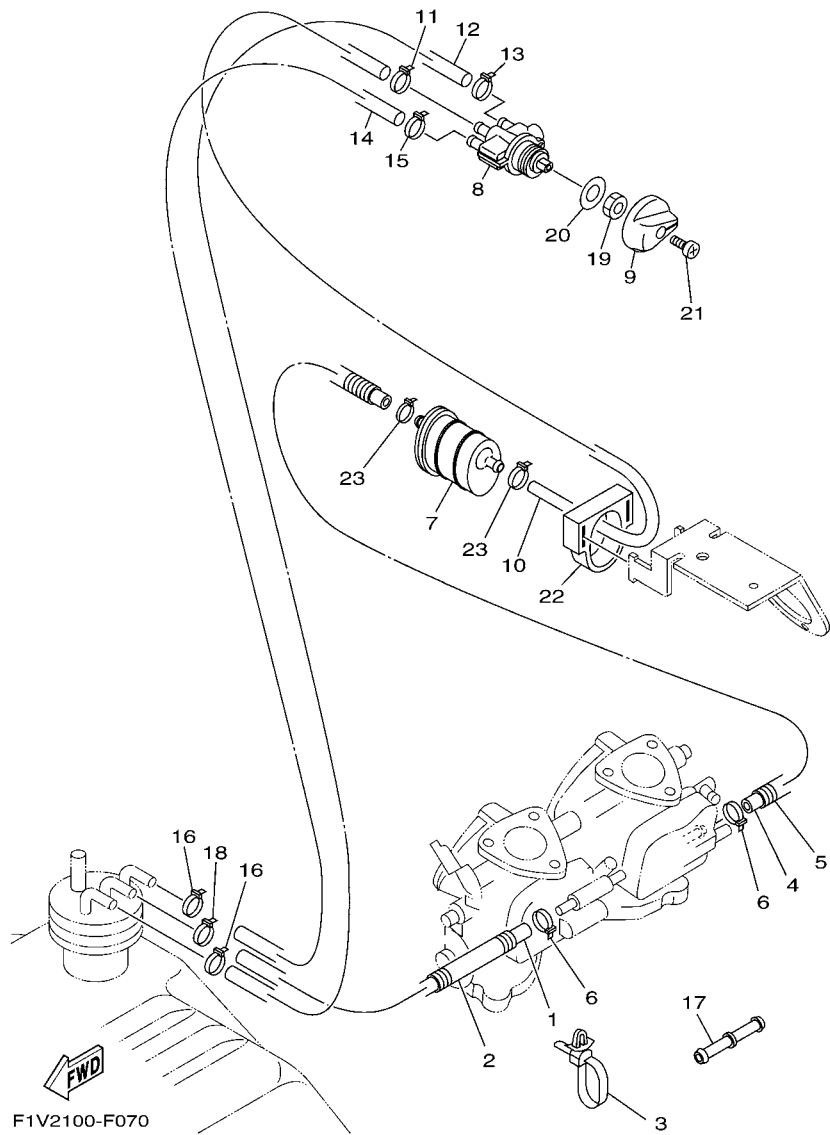

F1V2100-F070

FIG. 7 FUEL

REF. NO.	PART NO.	DESCRIPTION	QTY				REMARKS
1	90445-10037	HOSE (L1220)	1				
2	90447-13003	TUBE	1				
3	90465-12M56	CLAMP	1				
4	90445-10036	HOSE (L1220)	1				
5	90447-13003	TUBE	1				
6	90465-11M10	CLAMP	2				
7	66V-24560-00	FILTER ASSY	1				
8	66V-24500-02	FUEL COCK ASSY 1	1				
9	6K8-24524-10	LEVER, COCK	1				
10	90445-11040	HOSE (L700)	1				
11	90465-11M10	CLAMP	1				
12	90445-11006	HOSE (L580)	1				
13	90465-11M10	CLAMP	1				
14	90445-11008	HOSE (L550)	1				
15	90465-11M10	CLAMP	1				
16	90465-11829	CLAMP	2				
17	6G8-24376-00	PIPE, JOINT 1	1				
18	90465-11829	CLAMP	1				
19	90170-22187	NUT	1				
20	90202-229U1	WASHER, PLATE	1				
21	90159-04800	SCREW, WITH WASHER	1				
22	EU0-U7817-00	HOLDER, FILTER	1				
23	90465-11829	CLAMP	2				

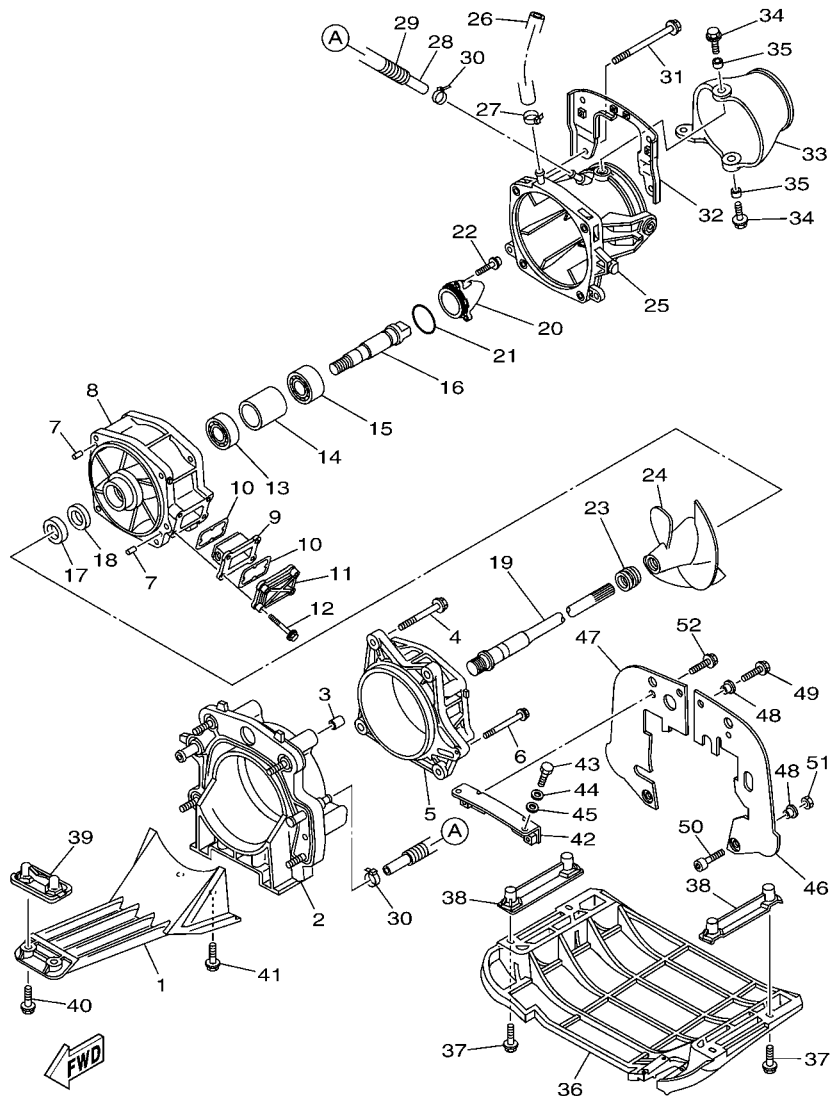

F1V1100-E081

FIG. 8 JET UNIT 1

REF. NO.	PART NO.	DESCRIPTION	QTY				REMARKS
1	6D3-R1333-00-94	SCREEN, INTAKE	1				
2	6AE-G5831-00	PLATE, TRANSOM	1				
3	99590-14016	PIN, DOWEL	2				
4	90119-10836	BOLT, WITH WASHER	4				
5	66V-51312-01-94	HOUSING, IMPELLER	1				
6	90119-06835	BOLT, WITH WASHER	1				
7	93606-12019	PIN, DOWEL	2				
8	66V-51315-00-94	DUCT, IMPELLER	1				
9	66V-46882-00	FILTER	1				
10	66V-42414-00	O-RING	2				
11	66V-45214-00-94	COVER, WATER INLET 1	1				
12	90119-06800	BOLT, WITH WASHER	4				
13	93306-27211	BEARING	1				
14	65V-45538-00	SPACER 1	1				
15	93306-205U0	BEARING	1				
16	6D3-45514-00	SHAFT, DRIVE 4	1				
17	93101-21001	OIL SEAL	1				
18	93101-21002	OIL SEAL	1				
19	6D3-45511-00	SHAFT, DRIVE	1				
20	65A-R1326-10	CAP	1				
21	93210-464A3	O-RING	1				
22	90119-069UB	BOLT, WITH WASHER	3				
23	6D3-R1319-00	CAP, IMPELLER	1				
24	6AE-R1321-00	IMPELLER	1				
25	6D3-R1318-00	NOZZLE	1				
26	90445-16006	HOSE (L260)	1				
27	90601-118UF	BAND, HOSE 18	1				

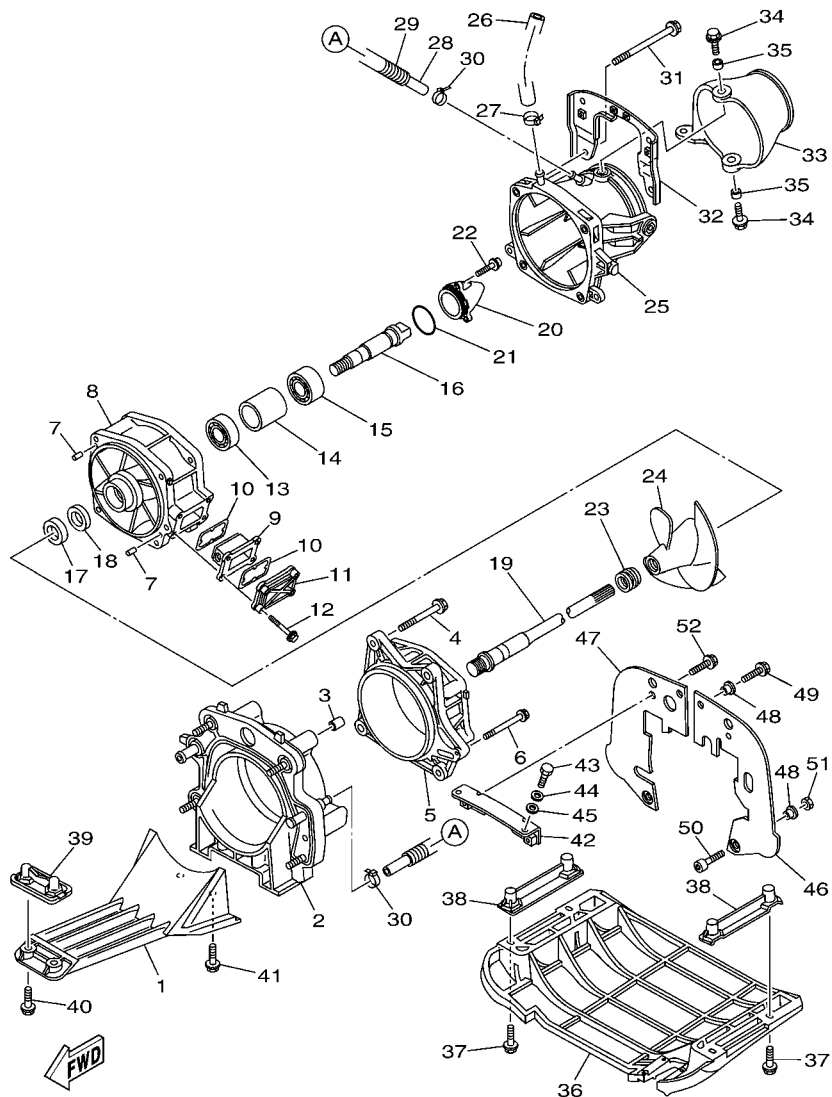

F1V1100-E081

FIG. 8 JET UNIT 1

REF. NO.	PART NO.	DESCRIPTION	QTY				REMARKS
28	90445-14008	HOSE (L355)	1				
29	90446-20MF5	HOSE (L320)	1				
30	90465-11829	CLAMP	2				
31	90119-10837	BOLT, WITH WASHER	4				
32	6D3-R1341-00	BRACKET 1	1				
33	6D3-R1313-00	NOZZLE, DEFLECTOR	1				
34	90119-08840	BOLT, WITH WASHER	2				
35	90387-08M06	COLLAR	2				
36	F1K-U273B-03	PLATE 2	1				
37	90119-08823	BOLT, WITH WASHER	4				
38	F1G-U8572-00	BRACKET 2	2				
39	F1K-U8577-00	BRACKET, 3	1				
40	90119-069UK	BOLT, WITH WASHER	2				
41	90119-10805	BOLT, WITH WASHER	2				
42	F1K-U7557-00	BRACKET	1				
43	90109-08041	BOLT	2				
44	92990-12200	WASHER, PLAIN	2				
45	90430-12002	GASKET	2				
46	F1K-U757E-01	PLATE, RUBBER 1	1				
47	F1K-U757F-01	PLATE, RUBBER 2	1				
48	90387-06080	COLLAR	6				
49	90119-06827	BOLT, WITH WASHER	4				
50	90101-069U0	BOLT	2				
51	9572R-06300	NUT, NYLON	2				
52	90119-089U7	BOLT, WITH WASHER	2				

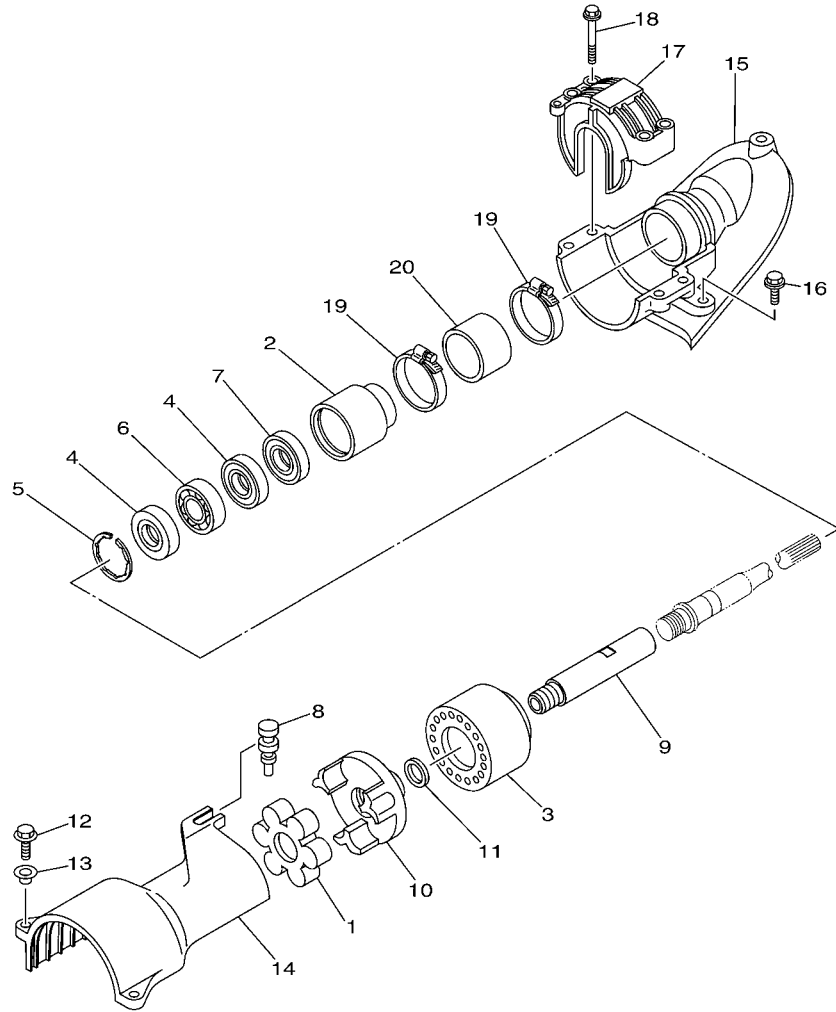

F1V3100-G090

FIG. 9 JET UNIT 2

REF. NO.	PART NO.	DESCRIPTION	QTY				REMARKS
1	61X-4581J-00	RUBBER SHAFT COUPLING	1				
2	6D3-45332-00-94	HOUSING, BEARING	1				
3	6D3-45235-00	DAMPER	1				
4	93101-25M55	OIL SEAL	2				
5	93430-47M04	CIRCLIP	1				
6	93306-205A3	BEARING	1				
7	93101-25M56	OIL SEAL	1				
8	90480-06M46	GROMMET	1				
9	6AE-51323-00	SHAFT, COUPLER	1				
10	6M6-45813-22-8P	FLANGE, COUPLING	1				
11	90201-248M5	WASHER, PLATE	1				
12	90119-069UD	BOLT, WITH WASHER	2				
13	90387-06M60	COLLAR	2				
14	63N-51381-00	COVER	1				
15	F1K-U883E-00	JOINT, PIPE	1				
16	90109-06832	BOLT	3				
17	F1V-U2155-00	CAP	1				
18	90119-089UU	BOLT, WITH WASHER	4				
19	90601-162U5	BAND, HOSE 62	2				
20	F1K-U883B-00	PIPE, 1	1				

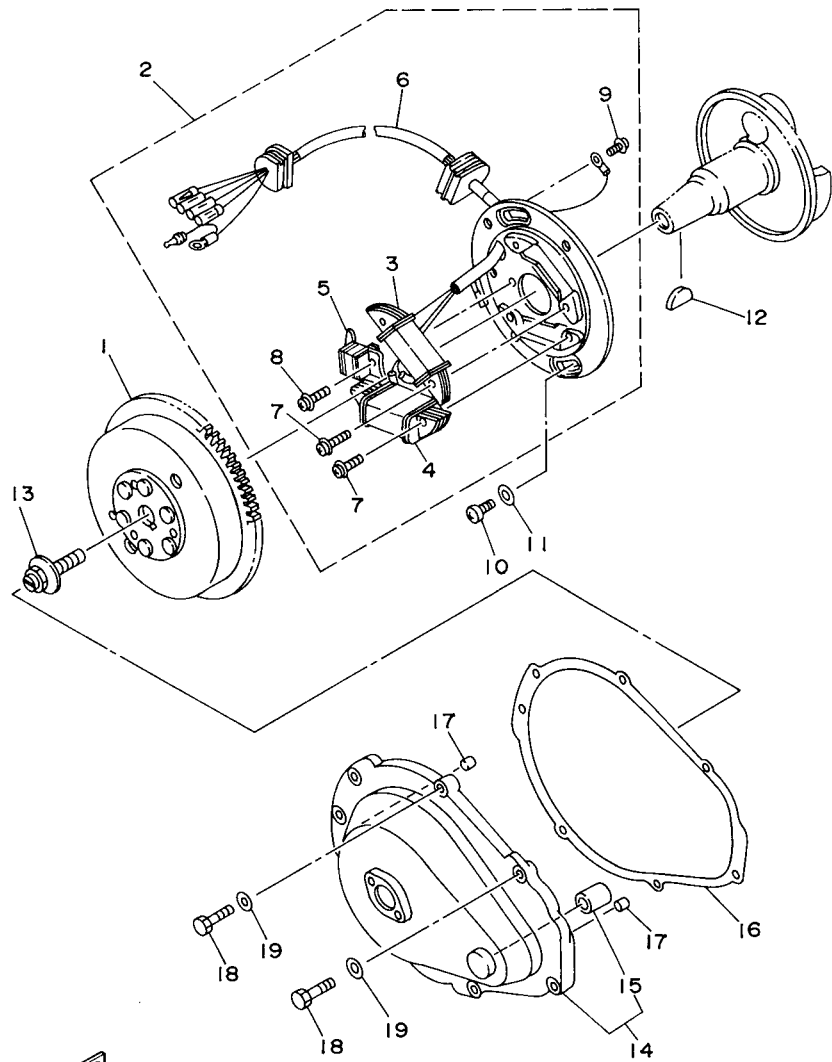

GHI4010-4100

FIG. 10 GENERATOR

REF. NO.	PART NO.	DESCRIPTION	QTY				REMARKS
1	62T-85550-00	ROTOR ASSY	1				
2	62T-85560-00	BASE ASSY	1				
3	62T-85520-01	.COIL, CHARGE	1				
4	62T-85533-00	.COIL, LIGHTING	1				
5	6M6-85580-00	.COIL, PULSER	1				
6	62T-85515-00	.LEAD WIRE ASSY	1				
7	97902-05125	.SCREW, WITH WASHER	4				
8	97902-04122	.SCREW, WITH WASHER	2				
9	97802-04008	.SCREW, PAN HEAD	1				
10	97880-06016	SCREW, PAN HEAD	2				
11	92990-06600	WASHER, PLATE	2				
12	90280-05013	KEY, WOODRUFF	1				
13	90109-10M47	BOLT	1				
14	6R8-81337-00-8S	COVER, FLYWHEEL	1				
15	90380-12M29	.BUSH, SOLID	1				
16	6M6-81365-A0	GASKET, HOLE COVER	1				
17	93606-12019	PIN, DOWEL	2				
18	97095-06025	BOLT	7				
19	92995-06600	WASHER	7				

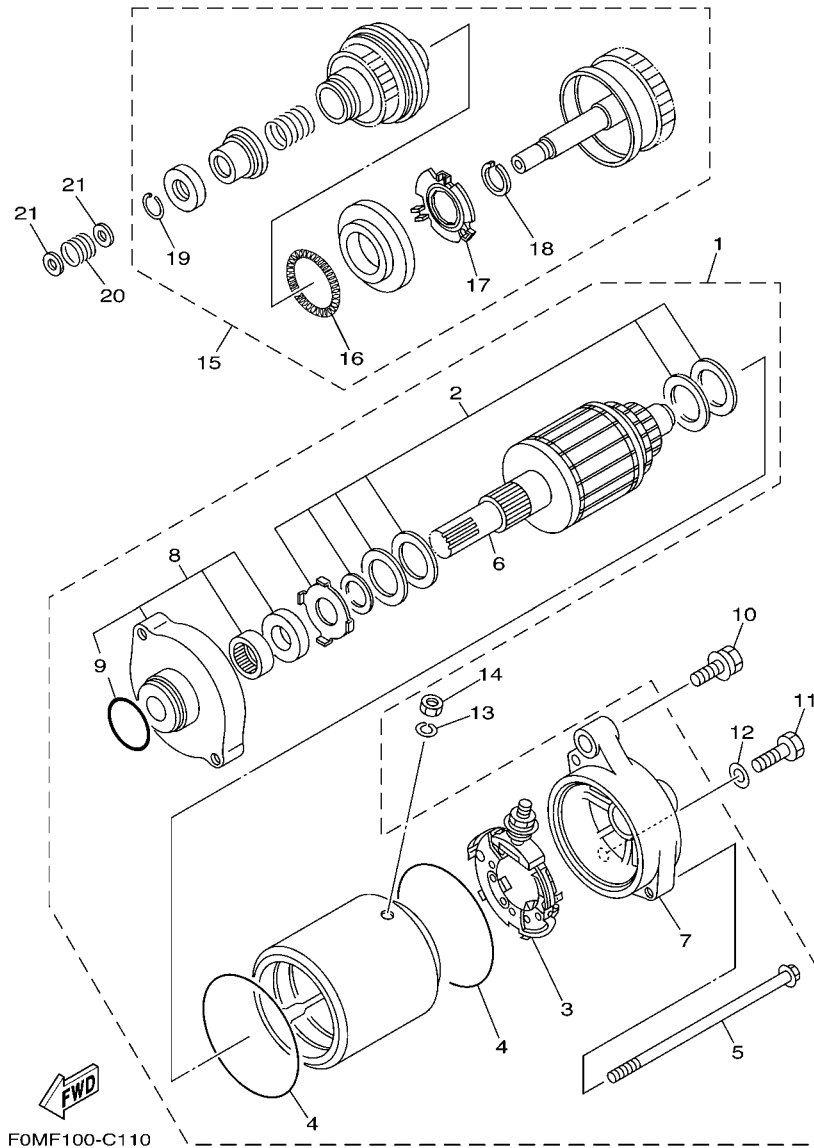
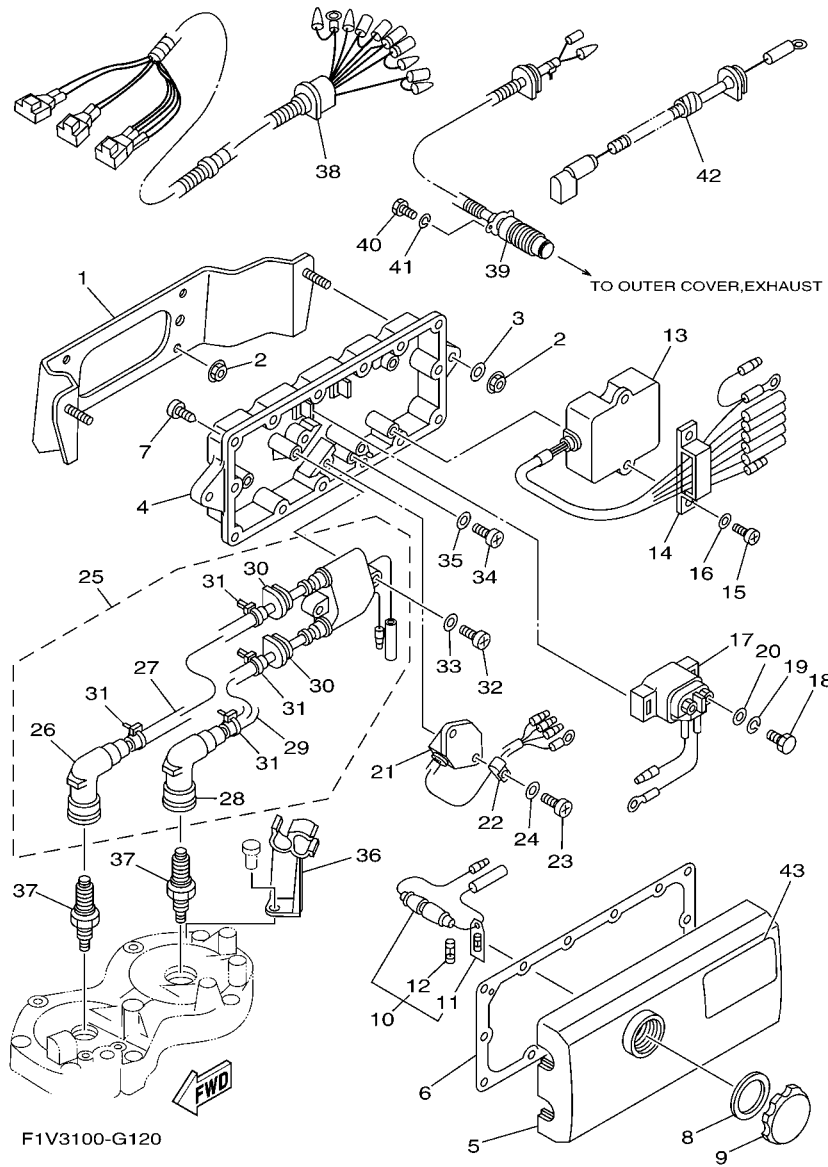

FIG. 11 STARTING MOTOR

REF. NO.	PART NO.	DESCRIPTION	QTY				REMARKS
1	6M6-81800-10	STARTING MOTOR ASSY	1				
2	3AJ-81809-00	.WASHER KIT	1				
3	6M6-81840-10	.BRUSH HOLDER ASSY	1				
4	11H-81844-00	.GASKET	2				
5	6M6-81826-00	.BOLT	2				
6	6M6-81850-00	.ARMATURE ASSY	1				
7	6M6-81820-00	.REAR BRACKET ASSY	1				
8	6M6-81830-00	.FRONT BRACKET ASSY	1				
9	26H-81847-00	..O-RING	1				
10	97513-08540	BOLT, WITH WASHER	1				
11	97013-08035	BOLT	1				
12	92903-08600	WASHER, PLATE	1				
13	92990-06100	WASHER, SPRING	1				
14	95380-06700	NUT	1				
15	6M6-8183E-01	IDLE GEAR COMP.	1				
16	6M6-81866-00	.WEIGHT SPRING	1				
17	6M6-81865-00	.WEIGHT HOLDER	1				
18	93440-25M08	.CIRCLIP	1				
19	93450-18M06	.CIRCLIP	1				
20	90501-14M73	SPRING, COMPRESSION	1				
21	92903-06600	WASHER, PLATE	2				



F1V3100-G120

FIG. 12 ELECTRICAL 1

REF. NO.	PART NO.	DESCRIPTION	QTY				REMARKS
1	F1V-U815D-00	BRACKET, ELECTRIC BOX	1				
2	9572R-08300	NUT, FLANGE	4				
3	9299R-08200	WASHER	2				
4	62L-8552A-00-8P	HOUSING	1				
5	6M6-8552E-01	COVER, CASE	1				
6	6M6-81921-00	GASKET, TERMINAL	1				
7	97780-60525	SCREW, TAPPING	14				
8	6M6-81844-00	GASKET	1				
9	6M6-8132W-00	CAP	1				
10	6K8-82150-01	FUSE HOLDER ASSY	1				
11	6G1-82151-00	.FUSE (10A)	1				
12	6K8-82159-00	.FUSE SPEAR (10A)	1				
13	62T-85540-01	C.D.I. UNIT ASSY	1				
14	90464-06M29	CLAMP	1				
15	97880-06016	SCREW, PAN HEAD	2				
16	92990-06600	WASHER, PLATE	2				
17	68N-81940-00	STARTER RELAY ASSY	1				
18	97095-06010	BOLT	2				
19	92995-06100	WASHER, SPRING	2				
20	92995-06600	WASHER	2				
21	6M6-81960-A0	RECTIFIER & REGULATOR ASSY	1				
22	90465-06M86	CLAMP	1				
23	97880-06016	SCREW, PAN HEAD	2				
24	92990-06600	WASHER, PLATE	2				
25	62E-85570-11	IGNITION COIL ASSY	1				
26	62E-82371-11	.CAP, PLUG	1				
27	62E-82351-01	.TUBE, CORD	1				



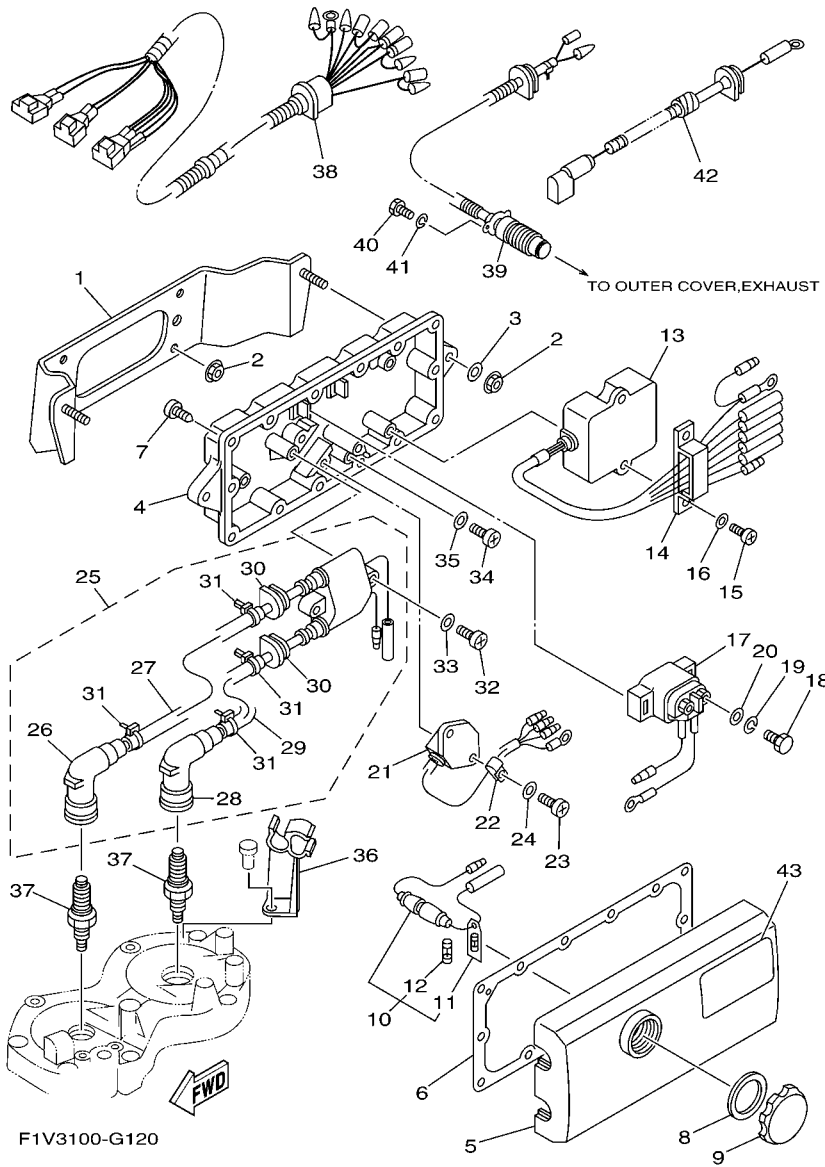

FIG. 12 ELECTRICAL 1

REF. NO.	PART NO.	DESCRIPTION	QTY				REMARKS
28	62E-82371-11	.CAP, PLUG	1				
29	62E-82352-01	.TUBE, CORD 2	1				
30	90480-06M43	.GROMMET	2				
31	90465-11M10	.CLAMP	4				
32	97880-06030	SCREW, PAN HEAD	2				
33	92990-06600	WASHER, PLATE	2				
34	97880-06016	SCREW, PAN HEAD	2				
35	92990-06600	WASHER, PLATE	2				
36	62T-82361-00	CLAMP, CORD	1				
37	94702-00195	PLUG, SPARK (NGK BR8HS)	2				
38	6AE-82553-00	EXTENSION, WIRE LEAD	1				
39	62T-82560-11	THERMO SWITCH ASSY	1				
40	97095-06016	BOLT	2				
41	92995-06100	WASHER, SPRING	2				
42	6AE-82117-20	WIRE, LEAD	1				
43	6B6-83623-00	MARK 3	1				

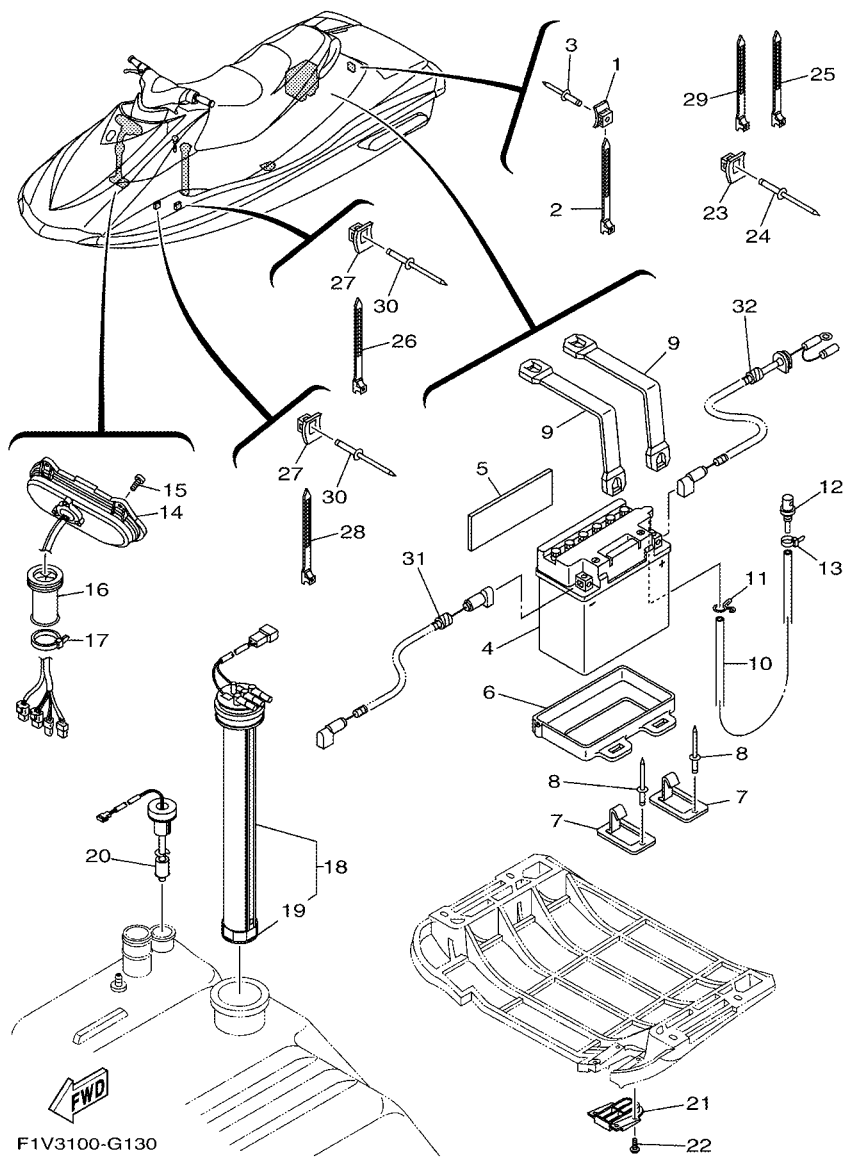

FIG. 13 ELECTRICAL 2

REF. NO.	PART NO.	DESCRIPTION	QTY				REMARKS
1	90600-917U4	CLAMP COMP.	1				
2	90464-32801	CLAMP	1				
3	90267-489U6	RIVET, BLIND	1				
4	EU0-82110-09	BATTERY ASSY (YB16CL-B)	1				YUASA
5	F1K-U8221-00	PAD, BATTERY	1				
6	F1K-U8211-01	CASE, BATTERY	1				
7	F1K-U5772-02	HOOK A	4				
8	90267-489U1	RIVET, BLIND	4				
9	F1K-U821D-00	BAND, BATTERY 1	2				
10	F0D-U785G-10	HOSE, AIR VENT	1				
11	90467-089U1	CLIP	1				
12	GJ3-6215F-00	NIPPLE	1				
13	90465-11829	CLAMP	1				
14	F1V-6820A-01	METER ASSY	1				
15	90111-05008	BOLT, HEX. SOCKET BUTTON	4				
16	GU2-6822E-01	GROMMET	1				
17	90601-200U1	BAND	1				
18	F0V-U824B-03	SENDER, FUEL	1				
19	F0V-H369N-00	.FLOAT	1				
20	GJ8-U824C-01	SENDER, OIL	1				
21	F1V-U273C-01	COVER, PLATE	1				
22	90150-05807	SCREW, ROUND HEAD	4				
23	90600-917U4	CLAMP COMP.	5				
24	90267-489U6	RIVET, BLIND	5				
25	90464-32801	CLAMP	4				
26	90601-200U2	BAND	1				
27	90600-917U4	CLAMP COMP.	2				

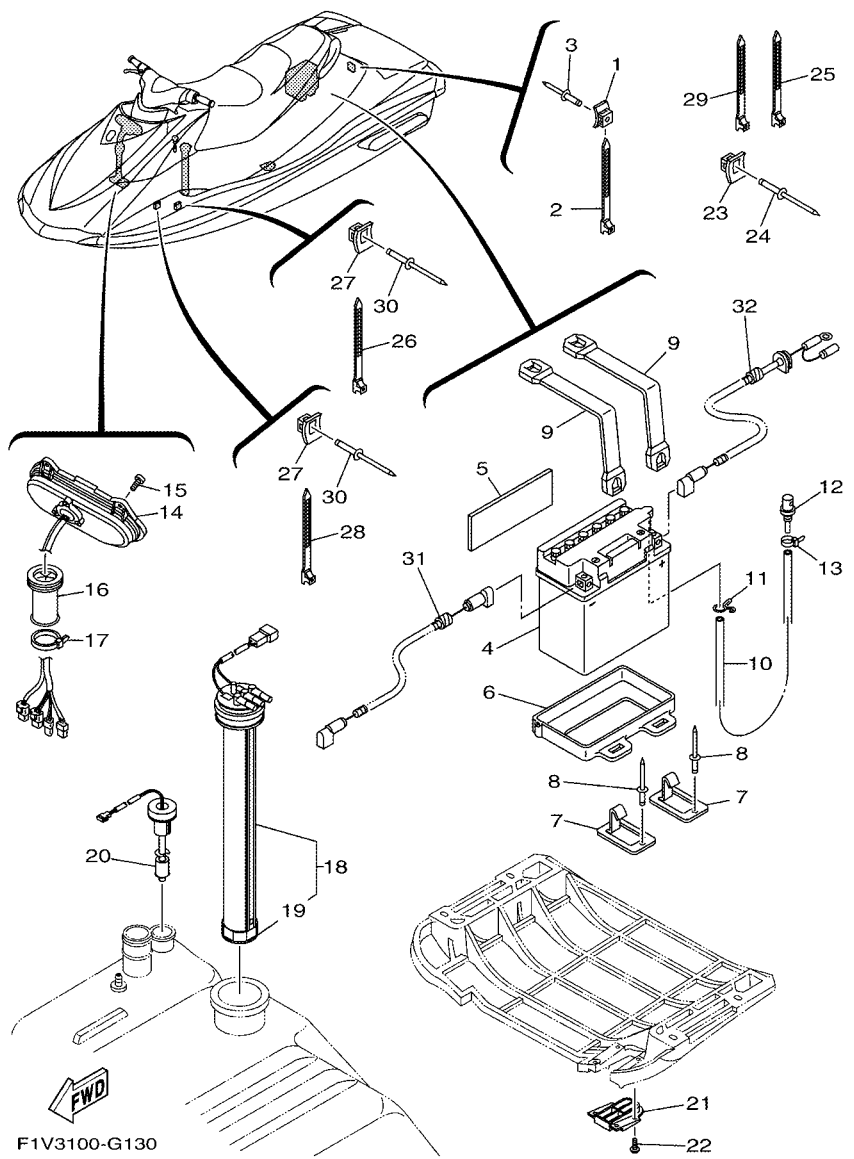
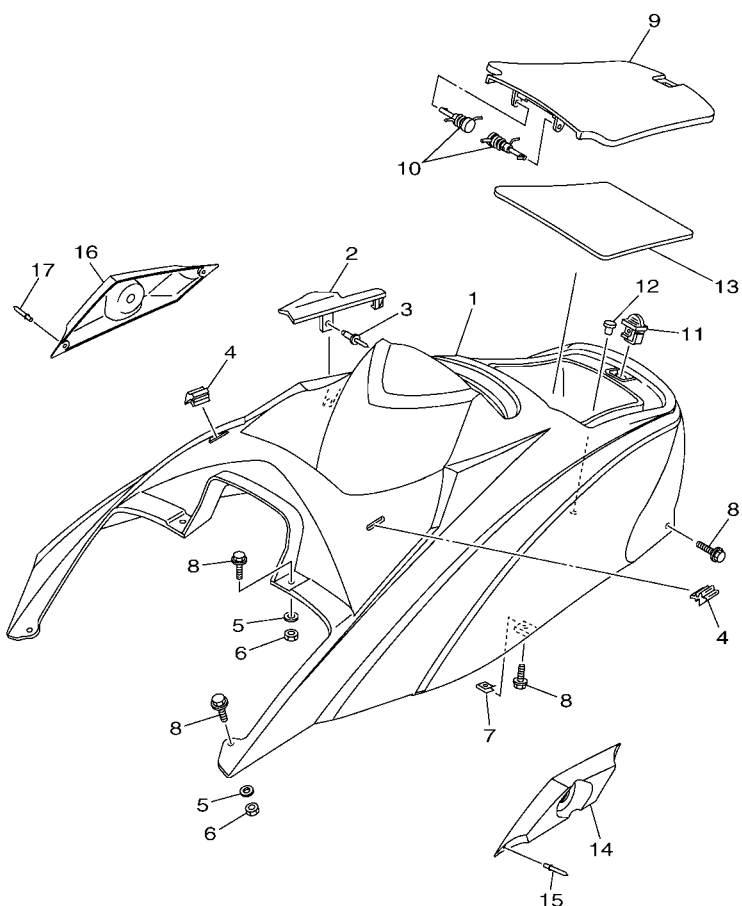

FIG. 13 ELECTRICAL 2

REF. NO.	PART NO.	DESCRIPTION	QTY				REMARKS
28	90464-32801	CLAMP	1				
29	90601-200U2	BAND	1				
30	90267-489U6	RIVET, BLIND	2				
31	6AE-82117-00	WIRE, LEAD	1				
32	63N-82117-10	WIRE, LEAD	1				
<hr style="border-top: 1px dashed black;"/>							
<hr style="border-top: 1px dashed black;"/>							
<hr style="border-top: 1px dashed black;"/>							
<hr style="border-top: 1px dashed black;"/>							
<hr style="border-top: 1px dashed black;"/>							
<hr style="border-top: 1px dashed black;"/>							
<hr style="border-top: 1px dashed black;"/>							
<hr style="border-top: 1px dashed black;"/>							
<hr style="border-top: 1px dashed black;"/>							

FIG. 14 ENGINE HATCH 1



REF. NO.	PART NO.	DESCRIPTION	QTY				REMARKS
1	F1K-U516N-03-P0	COVER, ENGINE HATCH	1				RM4
2	F1K-U2723-00	SEAL	1				
3	90269-09805	RIVET	1				
4	F1K-U266C-00	PACKING 4	2				
5	9299R-06200	WASHER	4				
6	9572R-06300	NUT, NYLON	4				
7	90183-06902	NUT, SPRING	2				
8	90119-06882	BOLT, WITH WASHER	8				
9	F1K-U517H-01	LID HATCH	1				
10	F0X-6517R-01	PIN, HINGE	2				
11	GU2-62875-01	LOCK	1				
12	90605-502U1	PLUG, BLIND	1				
13	F1K-U519D-00	PACKING CASE	1				
14	F1V-U7437-01	COVER (LH)	1				
15	90267-48824	RIVET, BLIND	2				
16	F1V-U7437-10	COVER (RH)	1				
17	90267-48824	RIVET, BLIND	2				

F1V1100-E140

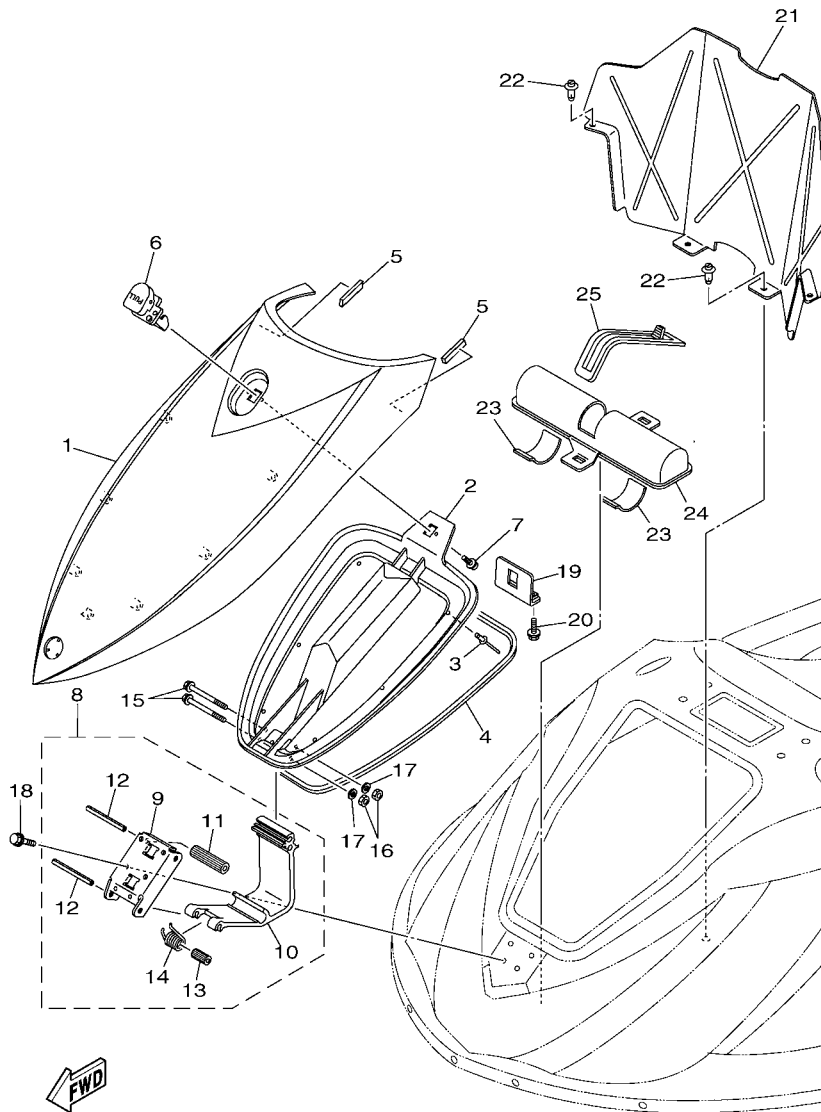

F1K1100-D200

FIG. 15 ENGINE HATCH 2

REF. NO.	PART NO.	DESCRIPTION	QTY				REMARKS
1	F1K-U517B-00-P0	LID, ENGINE ROOM	1				RM4
2	F1K-U2103-00	VENTILATOR COVER COMP., 2	1				
3	90267-48809	RIVET, BLIND	7				
4	F1K-U2663-00	PACKING 1	1				
5	F1K-U266B-00	PACKING 3	2				
6	F1K-6517C-00	LOCK, LID	1				
7	90159-059U2	SCREW, WITH WASHER	2				
8	F1K-U515A-00	HINGE ASSY.	1				
9	F1K-U518E-04	.PLATE, HINGE LID	1				
10	F1K-U517D-05	.HINGE, LID	1				
11	F1K-U135C-00	.ROLLER, DETENT	1				
12	F1K-U517R-00	.PIN, HINGE	2				
13	F1K-U471E-03	.SPACER 1	1				
14	F1K-U283B-02	.SPRING, TORSION	1				
15	90105-06826	BOLT, FLANGE	2				
16	9572R-06300	NUT, NYLON	2				
17	9299R-06200	WASHER	2				
18	90119-069UH	BOLT, WITH WASHER	4				
19	F1K-U517F-01	HOOK, LID LOCK	1				
20	90119-069UH	BOLT, WITH WASHER	2				
21	F1K-U475F-01	PLATE, LOKER BOW	1				
22	90269-08801	RIVET	4				
23	F1K-U759C-00	MAT 2	2				
24	F1K-U5983-01	BOX, FIRE EXTINGUISHER	1				
25	F1K-U828K-00	BAND, 1	1				

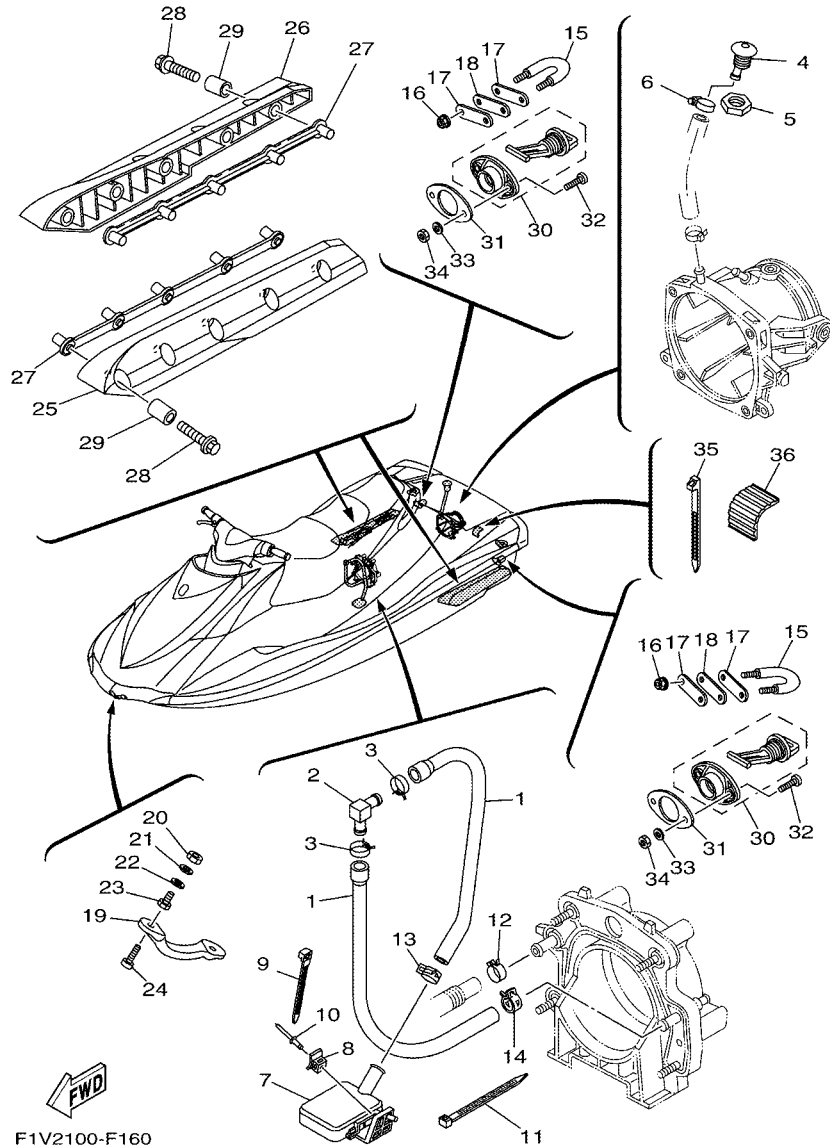

FIG. 16 HULL & DECK

REF. NO.	PART NO.	DESCRIPTION	QTY				REMARKS
1	90445-20805	HOSE (L710)	2				
2	61X-51162-00	JOINT, HOSE	1				
3	90467-18804	CLIP	2				
4	FN8-6269B-00	SPOUT	1				
5	EU0-61652-00	NUT	1				
6	90601-118UF	BAND, HOSE 18	1				
7	F1B-U761D-02	STRAINER, BILGE	1				
8	90600-917U4	CLAMP COMP.	1				
9	90464-32801	CLAMP	1				
10	90267-489U8	RIVET, BLIND	1				
11	90601-200U1	BAND	1				
12	90467-21800	CLIP	1				
13	90467-200A0	CLIP	1				
14	90467-210A0	CLIP	1				
15	F1K-61628-00	STERN EYE	2				
16	9572R-08300	NUT, FLANGE	4				
17	GP7-U4953-10	PLATE A	4				
18	F1B-U1653-01	PACKING	2				
19	F0X-61624-00	BOWEYE 1	1				
20	99780-12600	NUT.HEX.(COARS)	2				
21	92990-12200	WASHER, PLAIN	2				
22	F0X-61637-00	WASHER	2				
23	F0X-61652-00	NUT (BOLT/NUT)	2				
24	90110-06040	BOLT, HEXAGON SOCKET HEAD	2				
25	F1S-U883N-01	STABILIZER LH	1				BLACK
26	F1S-U883P-01	STABILIZER RH	1				BLACK
27	F1X-U883T-00	BRACKET,STABILIZER	2				



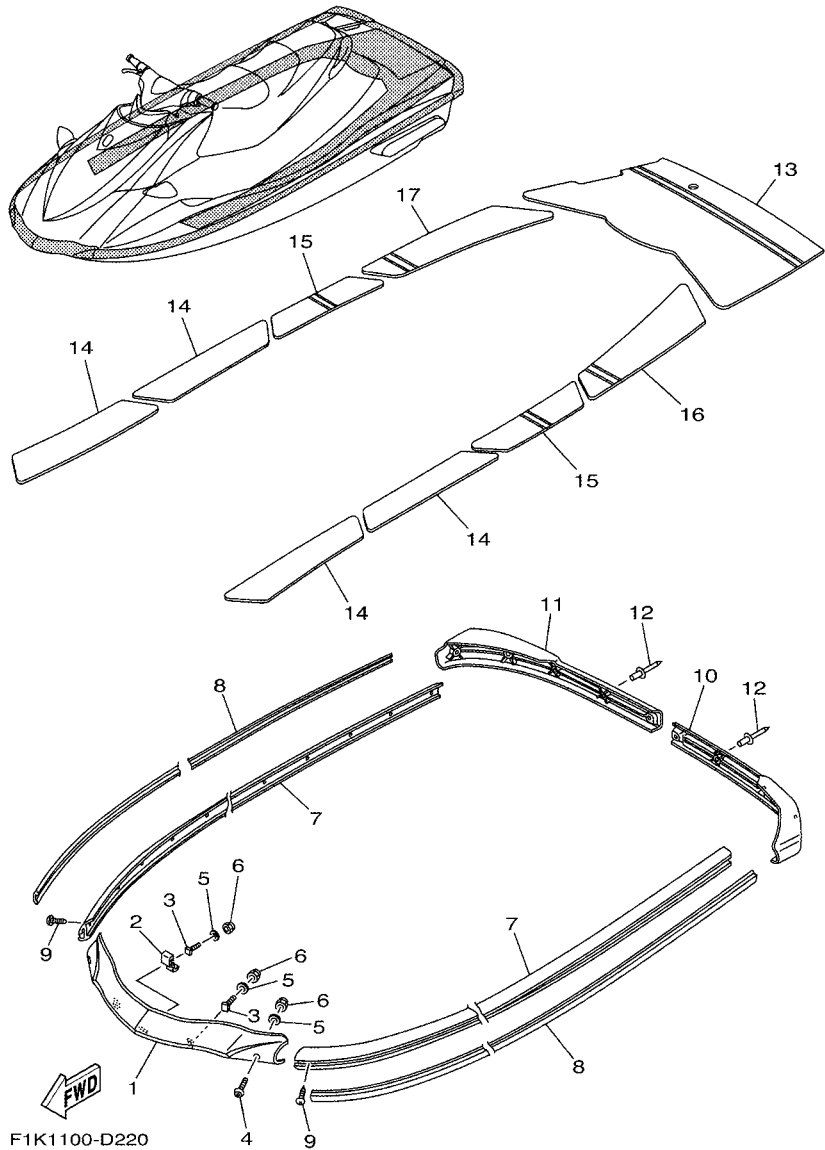
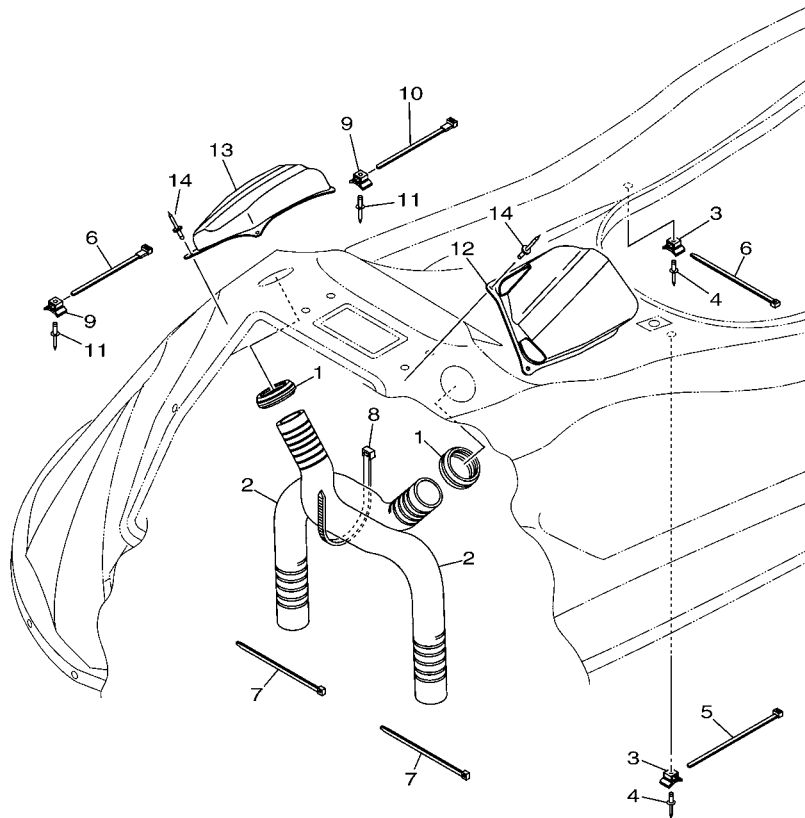

FIG. 17 GUNWALE & MAT

REF. NO.	PART NO.	DESCRIPTION	QTY				REMARKS
1	F1K-U2501-02	BOW GUNWALE COMP.	1				GRAY
2	F1K-U2521-02	PLATE	1				
3	F1K-U491K-00	BOLT, SPECIAL	3				
4	90111-06803	BOLT,HEX. SOCKET BUTTON	2				
5	9299R-06200	WASHER	5				
6	9572R-06300	NUT, NYLON	5				
7	F1K-U2512-03	GUNWALE, SIDE	2				GRAY
8	F1K-U2519-02	INNER,GUNWALE	2				GRAY
9	90169-059U1	SCREW,TAPPING	30				
10	F1K-U251D-01	GUNWALE, STERN 1	1				GRAY
11	F1K-U251E-01	GUNWALE, STERN 2	1				GRAY
12	90267-47801	RIVET, BLIND	9				
13	F1K-U3581-10	MAT, UPPER	1				GRAY
14	F1K-U351H-10	MAT, STEP 1	4				GRAY
15	F1K-U351J-10	MAT, STEP 2	2				GRAY
16	F1K-U351K-10	MAT, STEP 3	1				GRAY
17	F1K-U351M-10	MAT, STEP 4	1				GRAY





**FWD**  
F1V2100-F180

**FIG. 18 VENTILATION**

REF. NO.	PART NO.	DESCRIPTION	QTY				REMARKS
1	F1K-U2127-00	BASE, AIR INTAKE	2				
2	F1K-U213G-00	HOSE, VENTILATOR 2	2				
3	90600-917U4	CLAMP COMP.	2				
4	90267-489U6	RIVET, BLIND	2				
5	90601-200U2	BAND	1				
6	90601-200U2	BAND	2				
7	90464-99804	CLAMP	2				
8	90601-200U7	BAND	1				
9	90600-917U4	CLAMP COMP.	2				
10	90464-32801	CLAMP	1				
11	90267-489U6	RIVET, BLIND	2				
12	F1K-U2187-00	BOX, INDUCTION 1	1				
13	F1K-U2188-00	BOX, INDUCTION 2	1				
14	90267-48806	RIVET, BLIND	8				

**FIG. 19 SEAT & UNDER LOCKER**

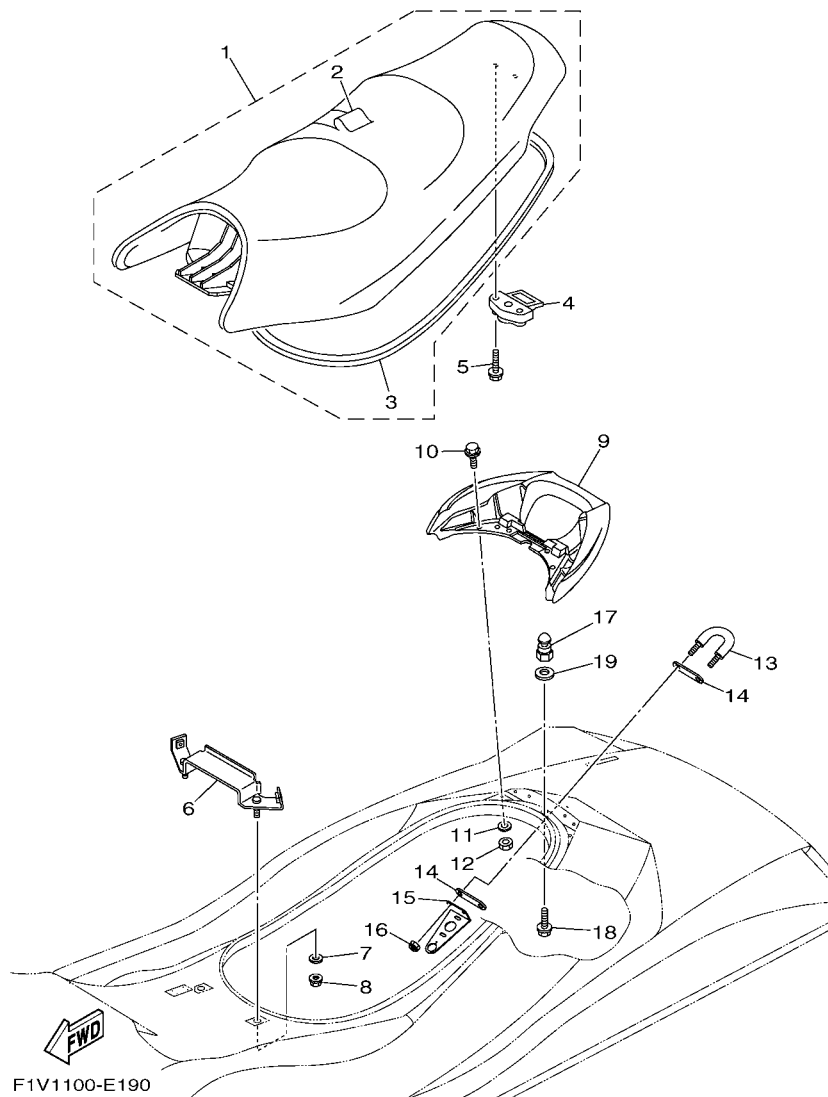

REF. NO.	PART NO.	DESCRIPTION	QTY				REMARKS
1	F1K-U371A-12	DOUBLE SEAT ASSY	1				
2	F1K-U371B-10	.COVER, SEAT 1	1				
3	F1K-U2664-01	.PACKING	1				
4	F1B-U3850-02	SEAT LOCK ASSY	1				
5	90119-069UP	BOLT, WITH WASHER	2				
6	F1K-U378C-00	STAY, SEAT 1	1				
7	90201-099U3	WASHER, PLATE	1				
8	9572R-08300	NUT, FLANGE	2				
9	F1K-U271B-04	GRIP, HAND	1				
10	90119-06820	BOLT, WITH WASHER	4				
11	9299R-06200	WASHER	4				
12	9572R-06300	NUT, NYLON	4				
13	F1K-61628-00	STERN EYE	1				
14	GP7-U4953-10	PLATE A	2				
15	F1V-U826C-01	BRACKET	1				
16	9572R-08300	NUT, FLANGE	2				
17	F1K-U3774-00	PIN	1				
18	90119-10804	BOLT, WITH WASHER	1				
19	9299R-10200	WASHER	1				

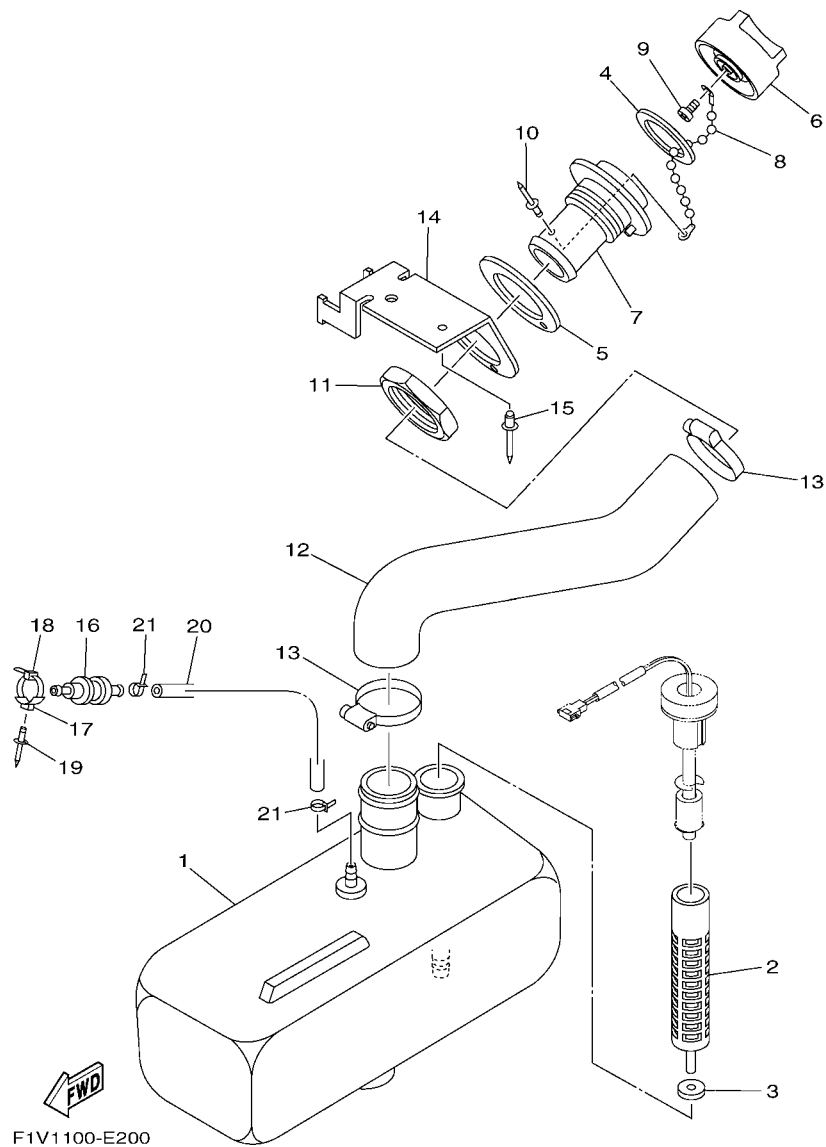
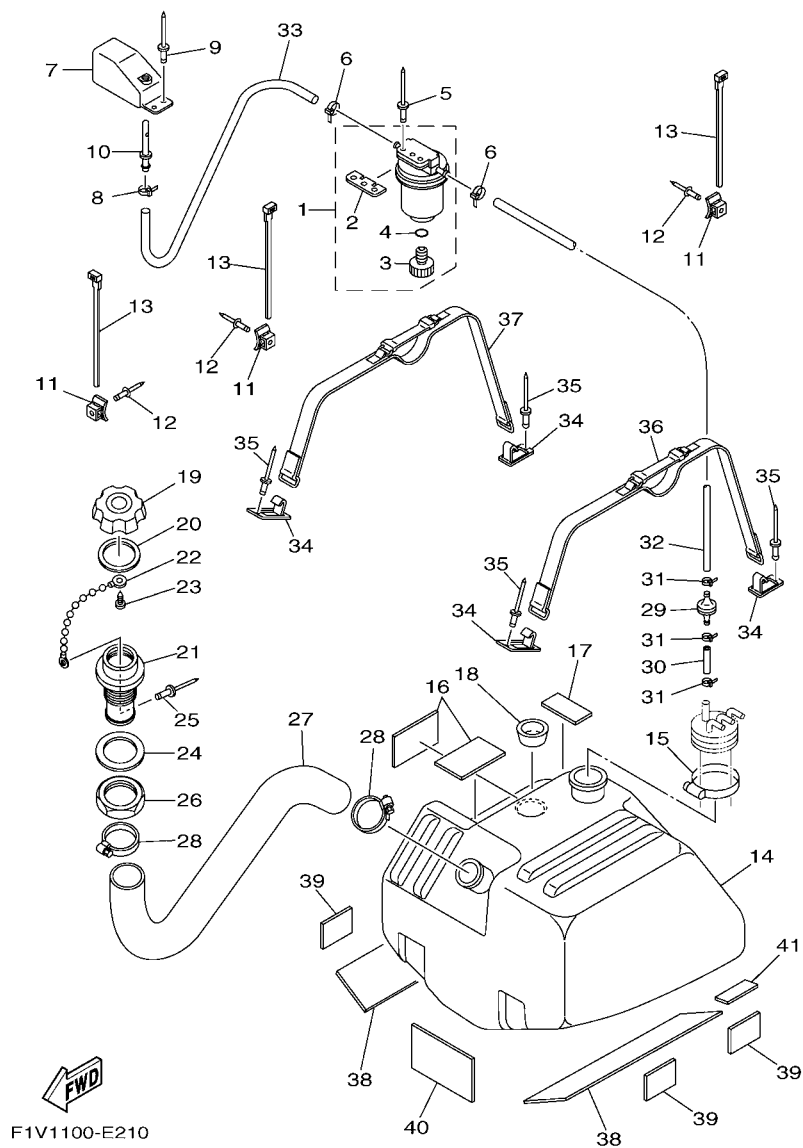

FIG. 20 OIL TANK

REF. NO.	PART NO.	DESCRIPTION	QTY				REMARKS
1	F1V-U775B-00	TANK, OIL	1				
2	6J8-13411-00	STRAINER, OIL	1				
3	6J8-13414-00	GASKET, STRAINER COVER	1				
4	GJ3-U778C-00	PACKING, OIL CAP	1				
5	F0X-U778E-01	PACKING, OIL FILLER	1				
6	F0X-U778B-00	CAP, OIL FILLER	1				
7	F0X-U778D-00	SOCKET, OIL FILLER	1				
8	EU0-U7835-00	CHAIN BALL	1				
9	97780-04110	SCREW, TAPPING	1				
10	90267-40935	RIVET, BLIND	1				
11	F0X-U778H-01	NUT, OIL FILLER	1				
12	F1V-U776C-00	HOSE, OIL FILLER	1				
13	90601-142U6	BAND, HOSE 42	2				
14	F1V-U781E-01	BRACKET, FILTER	1				
15	90267-489U1	RIVET, BLIND	1				
16	FJ0-67766-00	ROLL OVER VALVE	1				
17	90600-917U4	CLAMP COMP.	1				
18	90464-32801	CLAMP	1				
19	90267-489U6	RIVET, BLIND	1				
20	GU2-U785H-00	HOSE, AIR VENT 3	1				
21	90465-11829	CLAMP	2				

FIG. 21 FUEL TANK



F1V1100-E210

REF. NO.	PART NO.	DESCRIPTION	QTY				REMARKS
1	EW2-62140-00	FILTER, VENT ASSY	1				
2	EW2-62142-00	.PLATE, FILTER	1				
3	70R-24543-00	.PLUG, DRAIN	1				
4	70R-24489-00	.O-RING	1				
5	90267-489U2	RIVET, BLIND	2				
6	90465-11829	CLAMP	2				
7	GP7-62159-02	SOCKET, VENTILATION	1				
8	90465-11829	CLAMP	1				
9	90267-489U6	RIVET, BLIND	2				
10	F1G-62149-00	PIPE, VENTILATION	1				
11	90600-917U4	CLAMP COMP.	3				
12	90267-489U6	RIVET, BLIND	3				
13	90464-32801	CLAMP	3				
14	GU2-U7711-01	TANK, FUEL	1				
15	90601-162U5	BAND, HOSE 62	1				
16	GJ1-U759B-00	MAT 1	2				
17	GJ1-U759C-00	MAT 2	1				
18	GH1-U759D-00	MAT 3	1				
19	GP7-U7831-01	CAP, FUEL FILLER	1				PURW
20	GP7-U7832-01	PACKING	1				
21	GP7-U7833-00	SOCKET	1				PURW
22	GP7-U7835-00	CHAIN BALL	1				
23	90169-049U1	TAPPING SCREW	1				
24	GP7-U7834-00	PACKING FUEL FILLER	1				
25	90267-329UR	RIVET, BLIND	1				
26	GP7-U783F-00	NUT, FUEL FILLER	1				
27	F1V-U7844-00	HOSE	1				

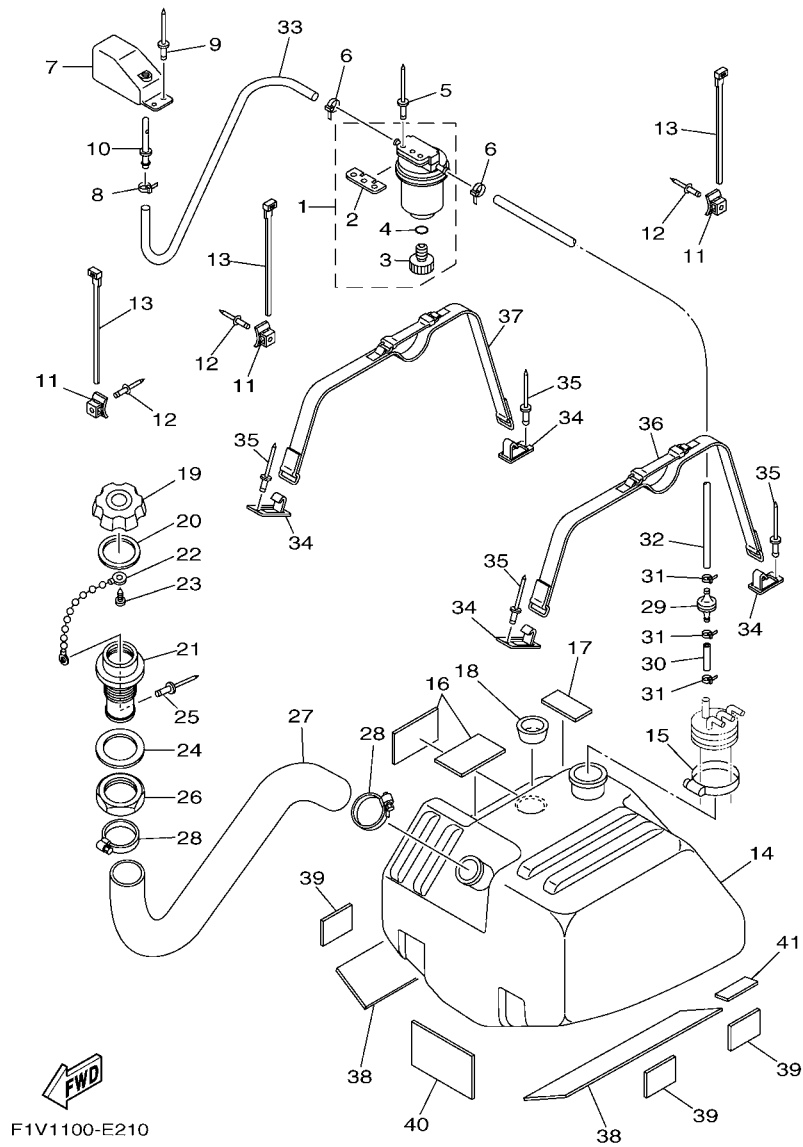

F1V1100-E210

FIG. 21 FUEL TANK

REF. NO.	PART NO.	DESCRIPTION	QTY				REMARKS
28	90601-155U4	BAND, HOSE 55	2				
29	EU0-67767-31	CHECK VALVE	1				
30	GP7-U785H-00	HOSE, AIR VENT 3	1				
31	90465-11829	CLAMP	3				
32	GJ3-U7856-10	HOSE, AIR VENT 3	1				
33	F0D-U7856-10	HOSE, AIR VENT 3	1				
34	F1K-U5772-02	HOOK A	4				
35	90267-489U1	RIVET,BLIND	4				
36	F1K-67743-00	BELT, TANK 1	1				
37	F1V-67743-00	BELT, TANK 1	1				
38	F1K-U759B-00	MAT 1	2				
39	F1B-U759C-00	MAT 2	4				
40	F1S-U8221-00	PAD, BATTERY	1				
41	F1K-U759C-00	MAT 2	2				

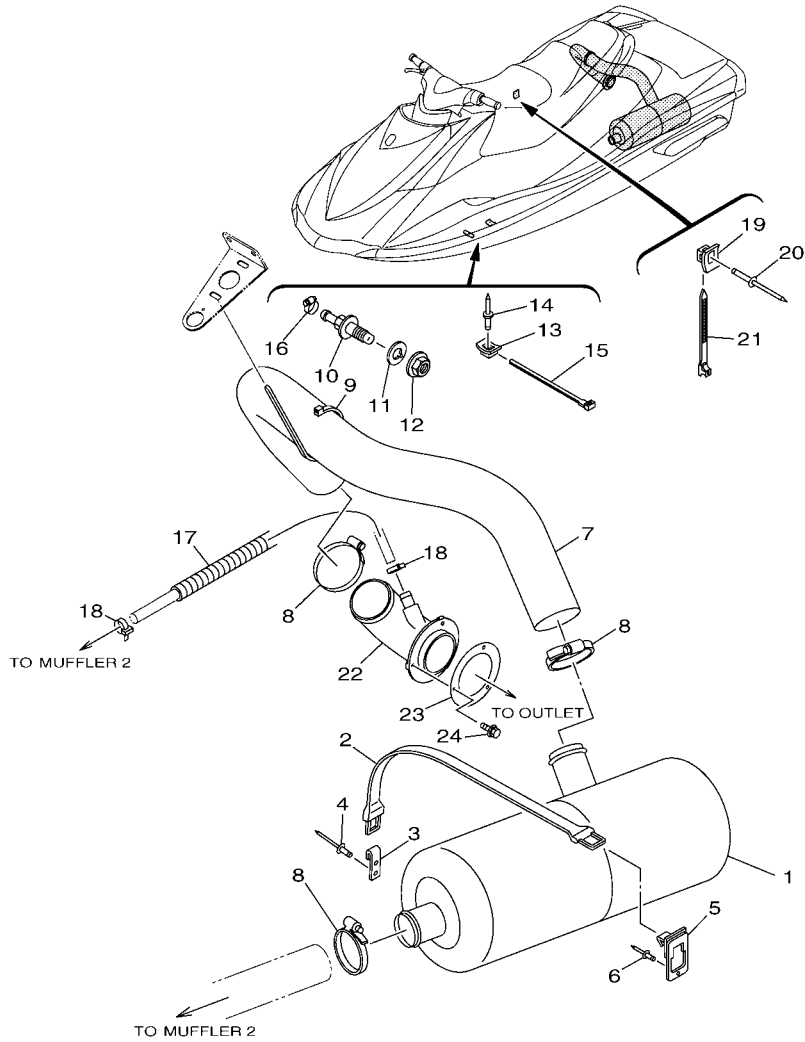

F1V1100-E220

FIG. 22 EXHAUST 2

REF. NO.	PART NO.	DESCRIPTION	QTY				REMARKS
1	GJ3-U7550-00	WATER LOCK COMP.	1				
2	EU0-U821D-00	BAND,BATTERY 1	1				
3	GA7-65772-00	HOOK A	1				
4	90267-489U1	RIVET,BLIND	2				
5	F1K-U5772-02	HOOK A	1				
6	90267-489U1	RIVET,BLIND	1				
7	F1V-U7555-00	HOSE, EXHAUST	1				
8	90601-170UG	BAND, HOSE 70	3				
9	90601-200U7	BAND	1				
10	F1G-6753B-00	PILOT, WATER	1				
11	F1B-67564-00	GASKET	1				
12	F0X-62733-00	NUT	1				
13	90600-917U4	CLAMP COMP.	1				
14	90267-489U6	RIVET, BLIND	1				
15	90464-32801	CLAMP	1				
16	90601-118UF	BAND, HOSE 18	2				
17	90447-22800	TUBE	1				
18	90601-200U1	BAND	2				
19	90600-917U4	CLAMP COMP.	1				
20	90267-489U6	RIVET, BLIND	1				
21	90464-32801	CLAMP	1				
22	GJ3-U7560-01	EXHAUST, THRU-HALL COMP.	1				
23	GA9-U7525-00	PACKING	1				
24	90119-059U4	BOLT, WITH WASHER	3				

D6

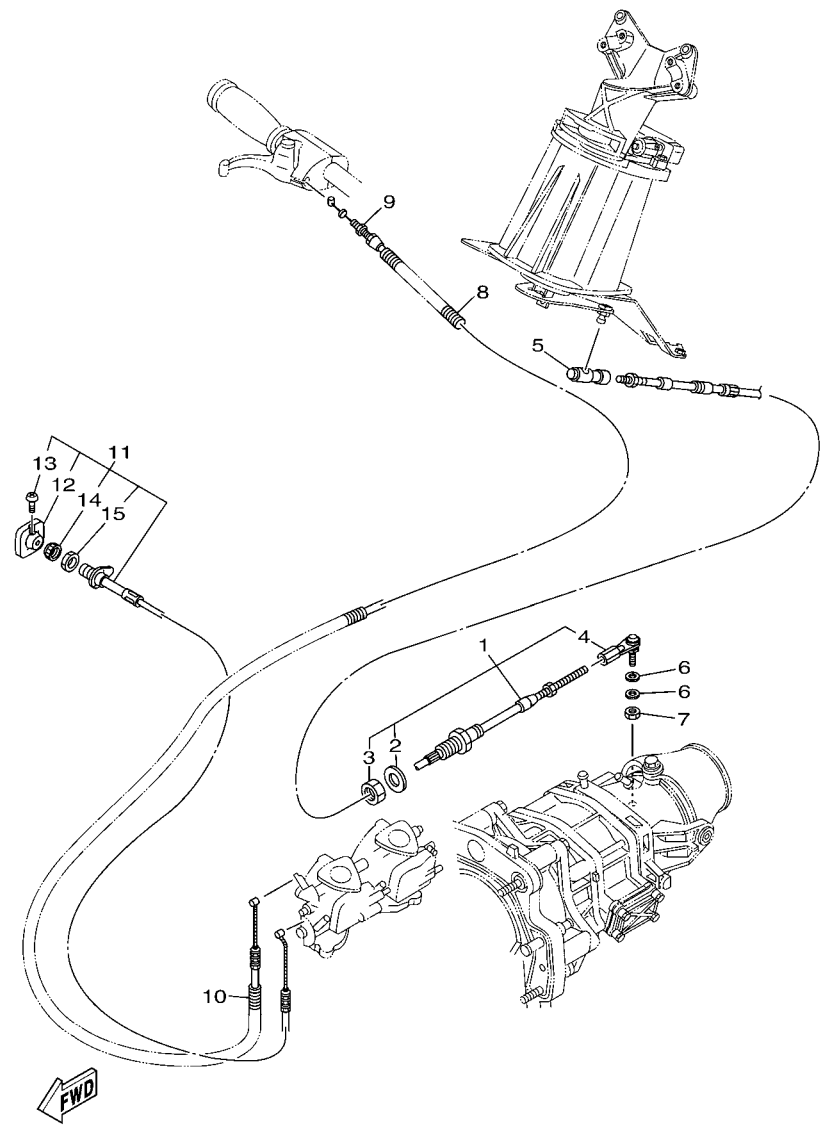

F1V2100-F230

FIG. 23 CONTROL CABLE

REF. NO.	PART NO.	DESCRIPTION	QTY				REMARKS
1	F1K-61481-01	CABLE, STEERING	1				
2	F1B-61438-00	.PACKING	1				
3	F1B-6151S-00	.NUT	1				
4	F1B-61461-02	.STUD, JOINT BALL	1				
5	GK5-U146F-00	SHAFT, JOINT BALL	1				
6	90201-06906	WASHER, PLATE	2				
7	9538R-06700	NUT	1				
8	90447-06802	TUBE	1				
9	F0M-U7252-00	CABLE, THROTTLE	1				
10	90447-09800	TUBE	1				
11	F1V-67242-01	CABLE, CHOKE	1				
12	EW2-67243-00	.KNOB	1				
13	90149-03930	.SCREW	1				
14	F0N-6724E-00	.NUT, COMPRESSION	1				
15	F0P-6724F-00	.NUT	1				

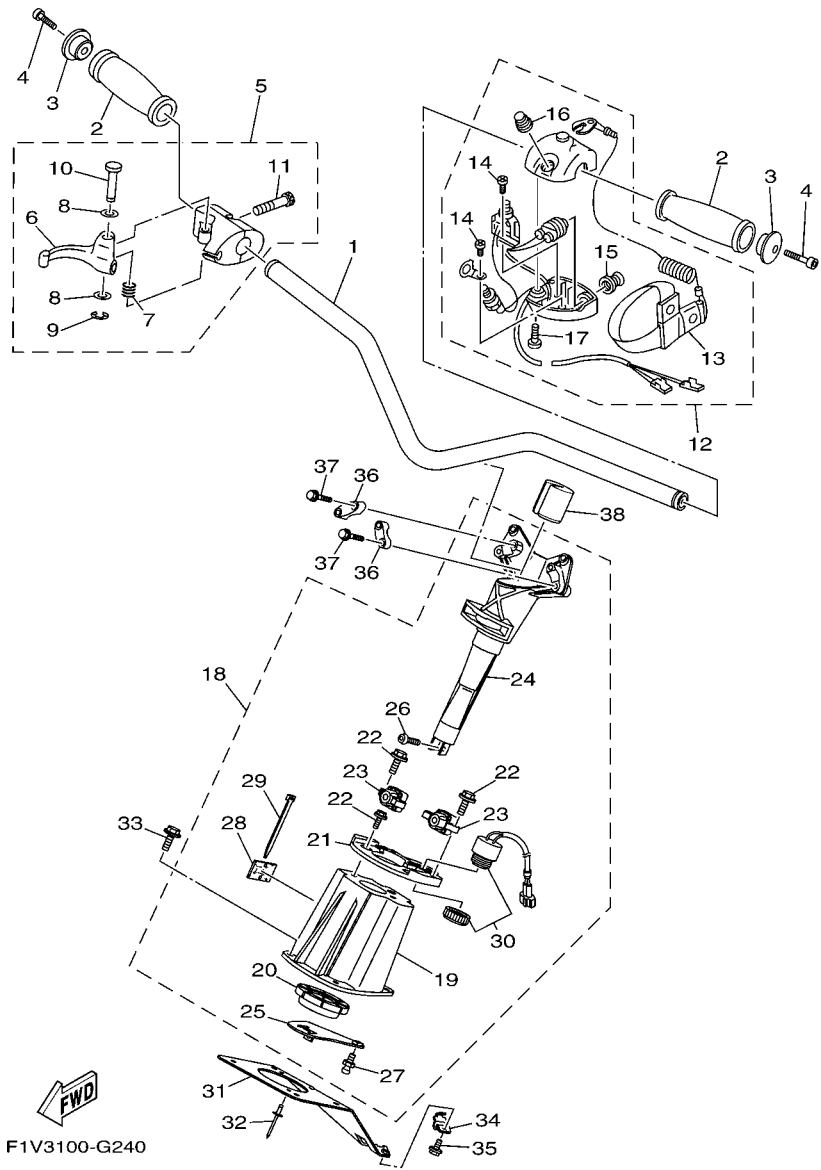

FIG. 24 STEERING 1

REF. NO.	PART NO.	DESCRIPTION	QTY				REMARKS
1	F1K-U1552-00	HANDLE	1				
2	GP7-U155D-01	GRIP, HANDLE	2				
3	GP7-U155F-00	GRIP, END	2				
4	90110-05908	BOLT, HEXAGON SOCKET HEAD	2				
5	F0D-67250-10	THROTTLE LEVER ASSY	1				
6	F0D-67255-02	.LEVER, THROTTLE	1				
7	EW2-67256-00	.SPRING	1				
8	EW2-67258-01	.WASHER	2				
9	EW2-67259-01	.E-RING	1				
10	F0D-67257-00	.SHAFT	1				
11	F1X-6725F-01	.BOLT, THROTTLE	2				
12	FK7-68310-07	SWITCH BOX ASSY	1				
13	EW2-68348-00	.LANYARD, STOP SWITCH	1				
14	97880-03008	.SCREW, PAN HEAD	2				
15	FK7-68312-02	.STOP BUTTON COMP	1				
16	FK7-68313-02	.START BUTTON COMP.	1				
17	97880-05025	.SCREW, PAN HEAD	2				
18	F1V-U154A-01	STEERING COLUMN COMP.	1				
19	F1K-U152M-00	.HOUSING ASSY	1				
20	F1K-U143C-00	.SEAL, RUBBER	1				
21	F1K-U146H-01	.SPACER, BRKT.	1				
22	90119-08826	.BOLT, WITH WASHER	7				
23	F1B-8A801-00	.CASE 1	2				
24	F1K-U1541-02	.COLUMN, STEERING	1				
25	F1K-U151B-02	.ARM, STEERING	1				
26	90119-08826	.BOLT, WITH WASHER	1				
27	GH3-U146E-00	.STUD, JOINT BALL	1				











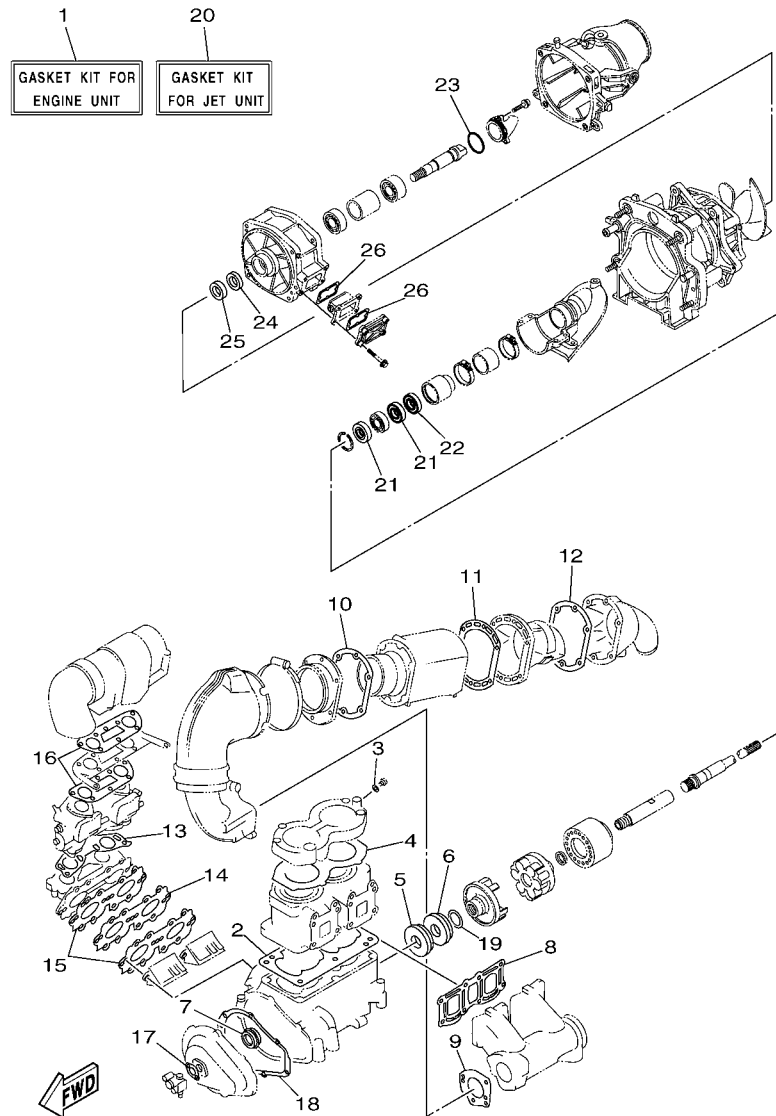

FOV1100-E280

FIG. 28 REPAIR KIT 1

REF. NO.	PART NO.	DESCRIPTION	QTY				REMARKS
1	62T-W0001-02	GASKET KIT FOR ENGINE UNIT	1				
2	6M6-11351-A2	.GASKET, CYLINDER	1				
3	90430-08020	.GASKET	1				
4	62T-11181-01	.GASKET, CYLINDER HEAD 1	1				
5	93102-36M33	.OIL SEAL	1				
6	93101-36M46	.OIL SEAL	1				
7	93103-32M01	.OIL SEAL	1				
8	62T-14613-01	.GASKET, EXHAUST PIPE	1				
9	62T-14749-01	.GASKET, MUFFLER DAMPER 2	1				
10	62T-41114-01	.GASKET, EXHAUST OUTER COVER	1				
11	62T-41122-00	.GASKET, EXHAUST INNER COVER	1				
12	62T-41124-00	.GASKET, EXHAUST OUTER COVER	1				
13	62T-13556-00	.GASKET, MANIFOLD	1				
14	62T-13624-00	.PLATE, REED VALVE	1				
15	62T-13566-00	.GASKET	2				
16	62T-13674-00	.GASKET, AIR COOLER COVER 1	2				
17	6R8-13116-A0	.GASKET, PUMP CASE	1				
18	6M6-81365-A0	.GASKET, HOLE COVER	1				
19	62T-45127-00	.SEAL	1				
20	6D3-W0001-20	GASKET KIT FOR JET UNIT	1				
21	93101-25M55	.OIL SEAL	2				
22	93101-25M56	.OIL SEAL	1				
23	93210-464A3	.O-RING	1				
24	93101-21002	.OIL SEAL	1				
25	93101-21001	.OIL SEAL	1				
26	66V-42414-00	.O-RING	2				

FIG. 29 REPAIR KIT 2

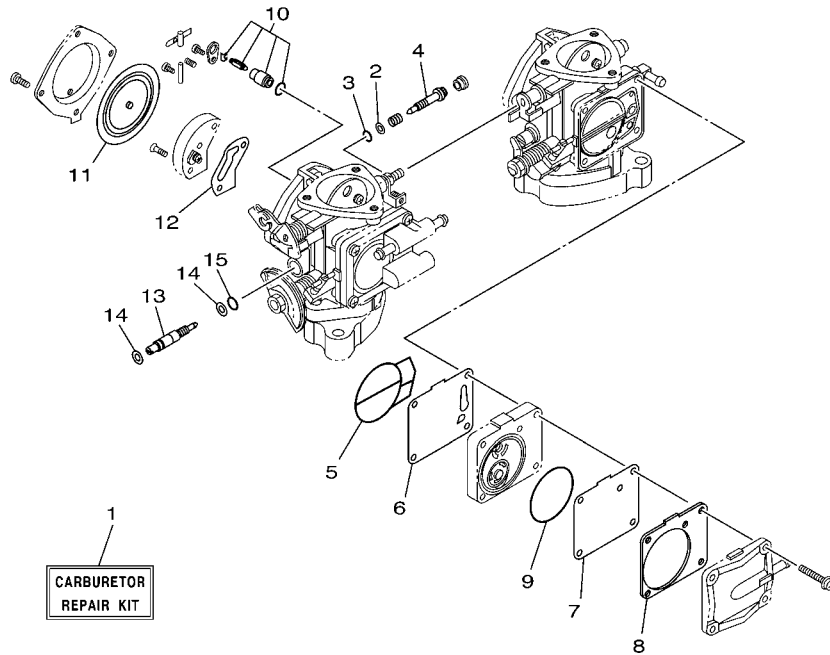

1  
CARBURETOR  
REPAIR KIT



GM6D100-9250

REF. NO.	PART NO.	DESCRIPTION	QTY				REMARKS
1	67E-W0093-00	CARBURETOR REPAIR KIT	1				
2	812-14235-00	.WASHER, NEEDLE	4				
3	812-14147-00	.O-RING	2				
4	6K8-14946-10	.METERING NEEDLE	2				
5	6K8-14564-00	.O-RING	2				
6	6K8-24411-20	.DIAPHRAGM	1				
7	6K8-24421-10	.VALVE, CHECK	1				
8	6K8-24431-20	.GASKET, FUEL PUMP 1	1				
9	6K8-14563-00	.O-RING	1				
10	61X-14916-16	.NEEDLE	2				
11	6R7-14541-00	.DIAPHRAGM, PUMP	2				
12	6K8-14536-11	.GASKET	2				
13	65U-14923-10	.SCREW, PILOT	2				
14	822-14235-00	.WASHER, NEEDLE	4				
15	583-14561-00	.O-RING	2				

NUMERICAL INDEX

PART NO.	GRID NO.	PART NO.	GRID NO.	PART NO.	GRID NO.	PART NO.	GRID NO.	PART NO.	GRID NO.	PART NO.	GRID NO.
62T-11111-00-8S	B - 2	812-14235-00	B - 8	62T-14749-01	B - 11	62E-44517-A1-8P	B - 2	F0N-6724E-00	D - 7	6K8-82159-00	C - 6
62T-11181-01	B - 2		D - 14		D - 13	61L-44532-00	B - 2	F0P-6724F-00	D - 7	62E-82351-01	C - 6
	D - 13	822-14235-00	B - 9	6AE-14752-00	B - 12	62T-45127-00	B - 5	F0D-67250-10	D - 8	62E-82352-01	C - 7
62T-11311-00-8S	B - 2		D - 14	62T-14771-00-94	B - 12		D - 13	F0D-67255-02	D - 8	62T-82361-00	C - 7
6E5-11325-00	B - 2	830-1423A-64	B - 8	61X-14916-16	B - 9	66V-45214-00-94	B - 15	EW2-67256-00	D - 8	62E-82371-11	C - 6
6M6-11351-A2	B - 2	62T-14251-10	B - 2		D - 14	6D3-45235-00	C - 3	F0D-67257-00	D - 8	6AE-82553-00	C - 7
	D - 13	6R7-14253-00	B - 9	65U-14923-10	B - 9	6D3-45332-00-94	C - 3	EW2-67258-01	D - 8	62T-82560-11	C - 7
6E5-11372-01	B - 6	62T-14255-00	B - 7		D - 14	6D3-45511-00	B - 15	EW2-67259-01	D - 8	6B6-83623-00	C - 7
62T-11400-02	B - 4	62T-14283-01	B - 7	3KW-14932-00	B - 8	6D3-45514-00	B - 15	F1X-6725F-01	D - 8	682-84385-01	B - 13
6M6-11412-00	B - 4	62T-14284-01-8S	B - 6	6K8-14946-10	B - 8	62T-45526-00	B - 4	F1G-6753B-00	D - 6	62T-85515-00	C - 4
6M6-11422-00	B - 4	62T-14293-00	B - 8		D - 14	65V-45538-00	B - 15	F1B-67564-00	D - 6	62T-85520-01	C - 4
6M6-11431-00	B - 4	62T-14301-03	B - 8	62T-15100-00-8S	B - 2	6M6-45813-22-8P	C - 3	F1K-67743-00	D - 5	62L-8552A-00-8P	C - 6
6M6-11442-01	B - 4	62T-14302-03	B - 8	63N-15761-00	B - 12	6M6-45813-32-8P	B - 5	F1V-67743-00	D - 5	6M6-8552E-01	C - 6
82M-11515-00	B - 4	62T-14419-00	B - 7	6R7-21415-01-94	B - 2	61X-4581J-00	C - 3	FJ0-67766-00	D - 3	62T-85533-00	C - 4
61X-11603-01	B - 4	62T-14435-00	B - 7	6R7-21425-01-94	B - 2	66V-46882-00	B - 15	EU0-67767-31	D - 5	62T-85540-01	C - 6
61X-11604-01	B - 4	62T-14451-00	B - 7	EU0-23814-30	D - 9	6K8-51129-00	B - 2	F1V-6820A-01	C - 8	62T-85550-00	C - 4
61X-11605-01	B - 4	6K8-14471-10	B - 8	62T-24313-01	B - 6		B - 11	GU2-6822E-01	C - 8	62T-85560-00	C - 4
62T-11631-02-92	B - 4	6H1-14485-00	B - 6	62T-24314-01	B - 6	61X-51162-00	C - 12	FK7-68310-07	D - 8	62E-85570-11	C - 6
62T-11633-00	B - 4	62T-14485-10	B - 11	6G8-24376-00	B - 14	66V-51312-01-94	B - 15	FK7-68312-02	D - 8	6M6-85580-00	C - 4
62T-11635-02	B - 4	6M6-14503-00	B - 8	6R3-24377-00	B - 12	66V-51315-00-94	B - 15	FK7-68313-02	D - 8	F1B-8A801-00	D - 8
62T-11636-02	B - 4	6K8-14503-02	B - 8	63N-24378-00	B - 11	6AE-51323-00	C - 3	F1S-68341-00	D - 9	67X-E2590-10	B - 13
62T-11651-00	B - 4	6K8-14521-00	B - 9	6K8-24411-20	B - 8	63N-51381-00	C - 3	EW2-68348-00	D - 8	6AE-G5831-00	B - 15
82M-11685-00	B - 4	6M6-14521-00	B - 8		D - 14	F1B-61438-00	D - 7	6M6-8132W-00	C - 6	F0V-H369N-00	C - 8
6AE-12564-00	B - 13	6K8-14521-10	B - 8	6R7-24412-01	B - 9	F1B-61461-02	D - 7	6R8-81337-00-8S	C - 4	6D3-R1313-00	C - 2
64T-12580-00	B - 13	6K8-14523-11	B - 9	6M6-24413-01	B - 8	F1K-61481-01	D - 7	6M6-81365-A0	C - 4	6D3-R1318-00	B - 15
64X-12581-00	B - 12	62T-14527-02	B - 6	65U-24421-00	B - 8	F1B-6151S-00	D - 7		D - 13	6D3-R1319-00	B - 15
6R8-13116-A0	B - 10	6K8-14527-11	B - 9	6K8-24421-10	B - 8	FOX-61624-00	C - 12	6M6-81800-10	C - 5	6AE-R1321-00	B - 15
	D - 13	6K8-14536-11	B - 9		D - 14	F1K-61628-00	C - 12	3AJ-81809-00	C - 5	65A-R1326-10	B - 15
67X-13183-00	B - 10		D - 14	6K8-24431-20	B - 8		D - 2	6M6-81820-00	C - 5	6D3-R1333-00-94	B - 15
61X-13200-12	B - 10	6R7-14541-00	B - 9		D - 14	FOX-61637-00	C - 12	6M6-81826-00	C - 5	6D3-R1341-00	C - 2
6J8-13411-00	D - 3		D - 14	6K8-24452-10	B - 8	EU0-61652-00	B - 13	6M6-81830-00	C - 5	F1K-U135C-00	C - 11
6J8-13414-00	D - 3	6R7-14542-00	B - 9	70R-24489-00	D - 4		C - 12	6M6-8183E-01	C - 5	F1K-U142D-00	D - 10
62T-13555-00-94	B - 6	6K8-14547-01	B - 9	65U-24492-00	B - 8	FOX-61652-00	C - 12	6M6-81840-10	C - 5	F1K-U143C-00	D - 8
62T-13556-00	B - 6	583-14561-00	B - 9	66V-24500-02	B - 14	EW2-62140-00	D - 4	11H-81844-00	C - 5	F1K-U143D-01	D - 10
	D - 13		D - 14	6K8-24524-10	B - 14	EW2-62142-00	D - 4	6M6-81844-00	C - 6	F1K-U143E-01	D - 10
62T-13566-00	B - 6	6K8-14563-00	B - 8	70R-24543-00	D - 4	F1G-62149-00	D - 4	26H-81847-00	C - 5	F1K-U1467-00	D - 9
	D - 13		D - 14	66V-24560-00	B - 14	GP7-62159-02	D - 4	6M6-81850-00	C - 5	F1K-U1468-03	D - 9
62T-13610-00	B - 6	6K8-14564-00	B - 8	62T-41113-00-8S	B - 11	GU3-6215F-00	C - 8	6M6-81865-00	C - 5	GH3-U146E-00	D - 8
62T-13624-00	B - 6		D - 14	62T-41114-01	B - 11	FN8-6269B-00	C - 12	6M6-81866-00	C - 5	GK5-U146F-00	D - 7
	D - 13	6R7-14569-00	B - 9		D - 13	FOX-62733-00	D - 6	6M6-81921-00	C - 6	F1K-U146H-01	D - 8
62T-13674-00	B - 6	6K8-14589-00	B - 9	62T-41121-00-8S	B - 12	GU2-62875-01	C - 10	68N-81940-00	C - 6	F1V-U146H-01	B - 3
	D - 13	62T-14613-01	B - 11	62T-41122-00	B - 12	F1K-6517C-00	C - 11	6M6-81960-A0	C - 6	F1K-U151B-02	D - 8
47X-14133-00	B - 8		D - 13		D - 13	FOX-6517R-01	C - 10	EU0-82110-09	C - 8	F1K-U152M-00	D - 8
812-14147-00	B - 8	62T-14615-01	B - 12	62T-41123-01-8S	B - 12	GA7-65772-00	D - 6	6AE-82117-00	C - 9	F1K-U1541-02	D - 8
	D - 14	62T-14625-00	B - 12	62T-41124-00	B - 12	EU0-65901-01	D - 11	63N-82117-10	C - 9	F1V-U154A-01	D - 8
439-14186-00	B - 9	62T-14711-10-94	B - 11		D - 13	EU0-65986-10	D - 11	6AE-82117-20	C - 7	F1K-U1552-00	D - 8
3G2-14231-24	B - 8	62T-14712-00-94	B - 11	66V-42414-00	B - 15	F1V-67242-01	D - 7	6K8-82150-01	C - 6	GP7-U155D-01	D - 8
3G2-14231-26	B - 8	62T-14721-00-8S	B - 11		D - 13	EW2-67243-00	D - 7	6G1-82151-00	C - 6	GP7-U155F-00	D - 8

NUMERICAL INDEX

PART NO.	GRID NO.	PART NO.	GRID NO.	PART NO.	GRID NO.	PART NO.	GRID NO.	PART NO.	GRID NO.	PART NO.	GRID NO.
F1K-U156E-01	D - 10	F1K-U41B1-11	D - 12	GH1-U759D-00	D - 4	90101-069U0	C - 2	90119-10M07	B - 2	90387-08M06	C - 2
F1B-U1653-01	C - 12	F1B-U41B1-21	D - 12	F1B-U761D-02	C - 12	90105-06826	C - 11	90119-10M17	B - 12	90430-08020	B - 2
F1K-U1949-00	D - 9	F0V-U41B1-31	D - 12	GU2-U7711-01	D - 4	90105-08860	C - 13	90119-10M56	B - 2		D - 13
F1K-U2103-00	C - 11	F1B-U41B2-01	D - 12	F1V-U775B-00	D - 3	90105-10M60	B - 11	90149-03930	D - 7	90430-12002	C - 2
F1K-U2127-00	C - 15	F0V-U41DB-12	D - 12	F1V-U776C-00	D - 3	90105-10M88	B - 12	90149-05903	D - 10	90445-07008	B - 10
F1K-U213G-00	C - 15	F0V-U41E1-41	D - 12	F0X-U778B-00	D - 3	90109-06832	C - 3	90150-05807	C - 8	90445-07009	B - 10
F1V-U2155-00	C - 3	F1B-U41F5-21	D - 12	GJ3-U778C-00	D - 3	90109-06M66	B - 7	90154-06017	D - 10	90445-10036	B - 14
F1K-U2187-00	C - 15	F1K-U471E-03	C - 11	F0X-U778D-00	D - 3	90109-08041	C - 2	90159-04800	B - 14	90445-10037	B - 14
F1K-U2188-00	C - 15	F1K-U475F-01	C - 11	F0X-U778E-01	D - 3	90109-08M56	B - 2	90159-059U2	C - 11	90445-11006	B - 14
F1S-U2280-00	C - 13	F1K-U491K-00	C - 14	F0X-U778H-01	D - 3	90109-10M47	C - 4	90167-04003	D - 10	90445-11008	B - 14
F1S-U2285-00	C - 13	GP7-U4953-10	C - 12	EU0-U7817-00	B - 14	90110-05908	D - 8	90169-049U1	D - 4	90445-11037	B - 10
F1K-U2501-02	C - 14		D - 2	F1V-U781E-01	D - 3	90110-06040	C - 12	90169-059U1	C - 14	90445-11040	B - 14
F1K-U2512-03	C - 14	F1K-U515A-00	C - 11	GP7-U7831-01	D - 4	90111-05008	C - 8	90170-22187	B - 14	90445-14008	C - 2
F1K-U2519-02	C - 14	F1K-U516N-03-P0	C - 10	GP7-U7832-01	D - 4	90111-06803	C - 14	90179-08M15	B - 6	90445-14M14	B - 12
F1K-U251D-01	C - 14	F1K-U517B-00-P0	C - 11	GP7-U7833-00	D - 4	90116-08M60	B - 6	90183-06902	C - 10	90445-14M24	B - 11
F1K-U251E-01	C - 14	F1K-U517D-05	C - 11	GP7-U7834-00	D - 4	90119-059U4	D - 6	90201-06906	D - 7	90445-14M25	B - 11
F1K-U2521-02	C - 14	F1K-U517F-01	C - 11	EU0-U7835-00	D - 4	90119-05M02	B - 7	90211-06M31	B - 7	90445-14M33	B - 11
F1K-U2663-00	C - 11	F1K-U517H-01	C - 10	GP7-U7835-00	D - 4	90119-06800	B - 15	90201-099U3	B - 3	90445-16006	B - 15
F1K-U2664-01	D - 2	F1K-U517R-00	C - 11	GP7-U783F-00	D - 4	90119-06820	D - 2		D - 2	90445-20805	C - 12
F1K-U266B-00	C - 11	F1K-U518E-04	C - 11	F1V-U7844-00	D - 4	90119-06827	C - 2	90201-20M04	B - 4	90445-21009	B - 12
F1K-U266C-00	C - 10	F1K-U519D-00	C - 10	F0D-U7856-10	D - 5	90119-06835	B - 15	90201-248M5	C - 3	90445-21010	B - 11
F1K-U271B-04	D - 2	F1K-U5772-02	C - 8	GJ3-U7856-10	D - 5	90119-06882	C - 10	90202-229U1	B - 14	90446-07M18	B - 10
F1K-U2723-00	C - 10		D - 5	F0D-U785G-10	C - 8	90119-069UB	B - 15	90267-329UR	D - 4	90446-07M48	B - 10
F1K-U273B-03	C - 2		D - 6	GP7-U785H-00	D - 5	90119-069UD	C - 3	90267-40935	D - 3	90446-20M13	B - 12
F1V-U273C-01	C - 8	F1K-U5983-01	C - 11	GU2-U785H-00	D - 3	90119-069UH	C - 11	90267-47801	C - 14	90446-20M31	B - 11
F1K-U283B-02	C - 11	F1V-U721B-02	B - 3	F1V-U815D-00	C - 6		D - 9	90267-48806	C - 15	90446-20MF5	C - 2
F1K-U351H-01	C - 14	F0M-U7252-00	D - 7	F1K-U8169-00	C - 13	90119-069UK	C - 2		D - 9	90447-06802	D - 7
F1K-U351J-10	C - 14	EU0-U7354-00-01	B - 3	F1K-U8211-01	C - 8	90119-069UP	D - 2	90267-48809	C - 11	90447-09800	D - 7
F1K-U351K-10	C - 14	EU0-U7354-00-03	B - 3	EU0-U821D-00	D - 6	90119-08823	B - 3	90267-48824	C - 10	90447-13002	B - 10
F1K-U351M-10	C - 14	EU0-U7354-00-05	B - 3	F1K-U821D-00	C - 8		C - 2	90267-489U1	C - 8	90447-13003	B - 14
F1K-U3581-10	C - 14	EU0-U7354-00-10	B - 3	F1K-U8221-00	C - 8	90119-08826	D - 8		D - 3	90447-15003	B - 11
F1K-U371A-12	D - 2	EU0-U7354-00-20	B - 3	F1S-U8221-00	D - 5	90119-08836	D - 9		D - 5	90447-22800	D - 6
F1K-U371B-10	D - 2	F1V-U7437-01	C - 10	F0V-U824B-03	C - 8	90119-08840	C - 2		D - 6	90450-14M05	B - 12
F1K-U3774-00	D - 2	F1V-U7437-10	C - 10	GJ8-U824C-01	C - 8	90119-089U7	C - 2	90267-489U2	D - 4	90450-18M09	B - 12
F1K-U378C-00	D - 2	GA9-U7525-00	D - 6	F1V-U826C-01	D - 2	90119-089UR	B - 3	90267-489U6	C - 8	90450-70M03	B - 12
F1B-U3850-02	D - 2	GJ3-U7550-00	D - 6	F1K-U828K-00	C - 11	90119-089UU	C - 3		C - 15	90450-99M01	B - 12
F1B-U411C-02	D - 12	F1V-U7555-00	D - 6	F1G-U8572-00	C - 2		D - 9		D - 3	90450-99M02	B - 12
F0V-U411C-10	D - 11	F1K-U7557-00	C - 2	F1K-U8577-00	C - 2	90119-08M11	B - 11		D - 4	90450-99M06	B - 12
F1K-U411H-00	D - 12	GJ3-U7560-01	D - 6	F1K-U883B-00	C - 3	90119-08M55	B - 2		D - 6	90464-06M29	C - 6
F1B-U415B-11	D - 12	F1K-U757E-01	C - 2	F1K-U883E-00	C - 3	90119-08M96	B - 2	90267-489U8	C - 12	90464-10M38	B - 10
GJ3-U416H-01	D - 12	F1K-U757F-01	C - 2	F1S-U883N-01	C - 12	90119-10804	D - 2	90269-08801	C - 11	90464-32801	C - 8
F1K-U417F-E0	D - 11	F1K-U759B-00	D - 5	F1S-U883P-01	C - 12	90119-10805	C - 2	90269-09805	C - 10		C - 12
F1K-U417G-E0	D - 11	GJ1-U759B-00	D - 4	F1X-U883T-00	C - 12	90119-10836	B - 15	90280-05013	C - 4		C - 15
F1V-U417H-10	D - 11	F1B-U759C-00	D - 5	62T-W0001-02	D - 13	90119-10837	C - 2	90340-08M04	B - 2		D - 3
F1V-U417J-10	D - 11	F1K-U759C-00	C - 11	6D3-W0001-20	D - 13	90119-10M00	B - 2	90380-12M29	B - 2		D - 4
F1V-U417K-10	D - 11		C - 13	62T-W0004-00	B - 6	90119-10M01	B - 2		C - 4		D - 6
F1V-U417L-10	D - 11		D - 5	62T-W0090-03-8S	B - 2	90119-10M02	B - 2	90387-06080	C - 2	90464-40825	C - 13
GA9-U418F-00	D - 12	GJ1-U759C-00	D - 4	67E-W0093-00	D - 14	90119-10M03	B - 2	90387-06M60	C - 3	90464-99804	C - 15



NUMERICAL INDEX

PART NO.	GRID NO.	PART NO.	GRID NO.	PART NO.	GRID NO.	PART NO.	GRID NO.	PART NO.	GRID NO.	PART NO.	GRID NO.
90465-06M86	C - 6	90605-502U1	C - 10	93430-47M04	C - 3	97902-04122	C - 4				
90465-08M69	B - 10	92903-06600	B - 6	93440-25M08	C - 5	97902-05125	C - 4				
90465-11829	B - 10		B - 12	93440-80023	B - 4	97980-05330	B - 8				
	B - 14		C - 5	93450-18M06	C - 5	98580-05018	B - 8				
	C - 2	92903-08600	B - 11	93450-21053	B - 4	98780-04015	B - 2				
	C - 8		C - 5	93603-10049	B - 5	99590-14016	B - 15				
	D - 3	92990-05600	B - 6	93604-07141	B - 5	99780-12600	C - 12				
	D - 4	92990-06100	C - 5	93605-12M21	B - 11						
90465-11M10	B - 6	92990-06600	C - 4	93606-12019	B - 2						
	B - 10		C - 6		B - 15						
	B - 11	92990-12200	C - 2		C - 4						
	B - 14		C - 12	94702-00195	C - 7						
	C - 7	92995-06100	C - 6	95380-06700	C - 5						
90465-11M59	B - 11	92995-06600	B - 10	9538R-06700	D - 7						
90465-12M56	B - 14		C - 4	9572R-05300	C - 13						
90467-089U1	C - 8		C - 6	9572R-06300	C - 2						
90467-18804	C - 12	9299R-05200	C - 13		C - 10						
90467-200A0	C - 12	9299R-06200	C - 10		C - 11						
90467-210A0	C - 12		C - 11		C - 14						
90467-21800	C - 12		C - 14		D - 2						
90468-02001	B - 10		D - 2	9572R-08300	C - 6						
90480-06M43	C - 7	9299R-08200	C - 6		C - 12						
90480-06M46	C - 3	9299R-10200	D - 2		D - 2						
90501-14M73	C - 5	93101-21001	B - 15	97013-06012	B - 7						
90600-900U6	D - 9		D - 13	97013-06016	B - 6						
90600-917U4	C - 8	93101-21002	B - 15	97013-06020	B - 6						
	C - 12		D - 13	97013-06025	B - 6						
	C - 15	93101-25M55	C - 3		B - 12						
	D - 3		D - 13	97013-06035	B - 6						
	D - 4	93101-25M56	C - 3	97013-06070	B - 12						
	D - 6		D - 13	97013-08035	C - 5						
90601-118UF	B - 13	93101-36M46	B - 4	97013-08075	B - 11						
	B - 15		D - 13	97095-06010	C - 6						
	C - 12	93102-36M33	B - 4	97095-06016	C - 7						
	D - 6		D - 13	97095-06025	C - 4						
90601-142U6	D - 3	93103-32M01	B - 4	97095-06035	B - 10						
90601-155U4	D - 5		D - 13	97513-08540	C - 5						
90601-162U5	C - 3	93210-13M63	B - 7	97780-04110	D - 3						
	D - 4	93210-464A3	B - 15	97780-60525	C - 6						
90601-170UG	D - 6		D - 13	97802-04008	C - 4						
90601-200U1	C - 8	93305-30601	B - 4	97880-03008	D - 8						
	C - 12	93306-205A3	C - 3	97880-05012	B - 9						
	D - 6	93306-205U0	B - 15	97880-05016	B - 6						
	D - 9	93306-207U2	B - 4	97880-05025	D - 8						
90601-200U2	C - 8	93306-27211	B - 15	97880-06016	C - 4						
	C - 15	93306-307U3	B - 4		C - 6						
90601-200U7	C - 15	93310-320U2	B - 4	97880-06030	C - 7						
	D - 6	93310-525U3	B - 4	9788R-05025	C - 13						