



**PARTS
CATALOGUE
CATALOGO
DE REPUESTOS**

E40G'07 (6F66)

E40J'07 (6J46)

E40G/E40J
PARTS CATALOGUE
©2006 by Yamaha Motor Co., Ltd.
1st edition, September 2006
All rights reserved.
Any reprinting or unauthorized use
without the written permission of
Yamaha Motor Co., Ltd.
is expressly prohibited.
Printed in Japan.

E40G/E40J
CATALOGO DE REPUESTOS
©2006 por Yamaha Motor Co., Ltd.
1ª edición, septiembre 2006
Todos los derechos reservados.
Toda reproducción o uso no autorizado
sin el consentimiento escrito de
Yamaha Motor Co., Ltd.
quedan expresamente prohibidos
Impreso en Japón.

FOREWORD

This Parts Catalogue is related to the parts for the model(s) on the cover page. When you are ordering replacement parts, please refer to this Parts Catalogue and quote both part numbers and part names correctly.

1. Modifications or additions which have been made after the issue of the Parts Catalogue will be announced in the Parts News.
It is advisable that you make the necessary corrections to the Parts Catalogue according to the Parts News.

2. Abbreviations
The following abbreviations are used in this Parts Catalogue.

“UR” Use specified parts number.
 “UN” Use as many as needed.
 “AP” Alternate Parts
 “LM” Locally Made (Parts need to be ordered locally)
 “F#” Frame No. (Applicable machine No.)
 “O/S” Over Size

3. The number of components for assembly
 - Parts, which are to be supplied in an assembly, are listed with a dot (.) in front of the part name as shown below.
 - The numeral appearing to the right of each component part indicates the quantity of parts for each assembly unit.

PART NO.	DESCRIPTION	Q'TY	REMARKS
2F5-83310-60	FRONT FLASHER LIGHT ASSY	2	
115-83311-60	.BULB (6V-18W)	1	

4. Applicable colours of graphics are represented in the “REMARKS” as shown below.

PART NO.	DESCRIPTION	Q'TY	REMARKS
2N4-24110-00-X5	FUEL TANK COMP.	2	MXR
3J1-24240-10	.GRAPHIC, FUEL TANK	1	FOR MXR

5. Note that the illustrations for reference in finding parts numbers are not to be used for assembling. When assembling, please use the applicable service manual.

6. The asterisk (*) before a reference number indicates modified items after the first edition.
7. Applicable Serial No.

Engine Serial No.

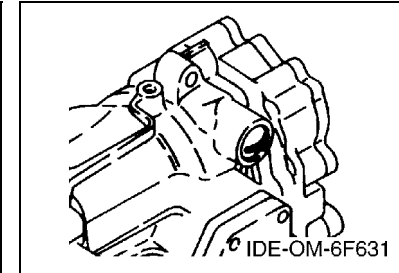
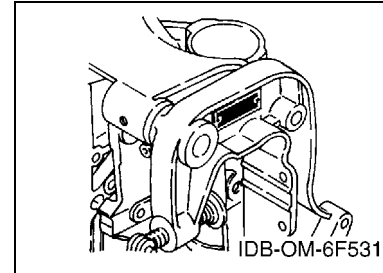

8. Applicable Engine Starting Serial No.

Model	Serial No.	Model	Serial No.
E40G	6F6K-1033228	E40J	6J4K-1014119

9. Applicable Colour Code

Abbreviation	Colour Name	Colour Code
DBNM2	DARK BLUISH GRAY METALLIC 2	004D

10. Quantity Column Information

Column No.	Name Of Q'ty Column	Applicable Model
1	E40M	E40GMH
2	40MH	E40JMH
3	E40W	E40GWH
4	40WH	E40JWH
5	40W	E40JW

PROLOGO

Este catálogo de repuestos corresponde a las piezas para el o los modelos que figuran en la página de portada. Al formular el pedido de repuestos, se ruega citar este catálogo y especificar correctamente el número y el nombre de las piezas.

- Las modificaciones y agregados que se hayan realizado después de la edición de este Catálogo de Repuestos, serán anunciados en las Informaciones de Recambios. Es recomendable que se hagan las correcciones necesarias en el Catálogo de Repuestos de acuerdo con las Informaciones de Recambios.

2. Abreviaciones

En este. Catálogo de Repuestos se emplean las siguientes abreviaciones.

“UR” Usar el número de partes especificado

“UN” Usar la cantidad necesaria

“AP” Piezas sustitutivas

“LM” Fabricación local (Hay que pedir los repuestos en las cercanías)

“F#” N° de bastidor (N° aplicable a la máquina)

“O/S” Sobredimensionado

3. La cantidad de componentes para el montaje

- Los componentes, suministrados como conjunto, se describen con un punto (.) que precede al nombre del parte como se indica a continuación.
- La numeración que aparece a la derecha de cada descripción indica la cantidad de partes por cada unidad de conjunto.

CODIGO N°	DESCRIPCION	CANT.	OBSERVACIONES
2F5-83310-60	ENSAMBLAJE DE LA LUZ	2	
115-83311-60	.BOMBILLA (6V-18W)	1	

4. Los colores de los componentes se indican como sigue en la columna de “OBSERVACIONES”.

CODIGO N°	DESCRIPCION	CANT.	OBSERVACIONES
2N4-24110-00-X5	COMP. DEL TANQUE	2	MXR
3J1-24240-10	.GRAFICO, DEL TANQUE	1	PARA MXR

- Debe tenerse en cuenta que las ilustraciones sirven como guía para la búsqueda de los números de partes y no deben usarse para el montaje. Durante el montaje, se recomienda usar el manual de taller correspondiente.

- EL asterisco (*) antes del número de referencia indica los elementos modificados después de la primera edición.

7. Números de serie

N° de Serie del motor

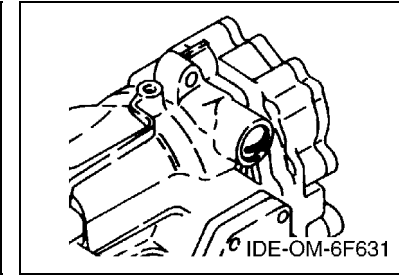
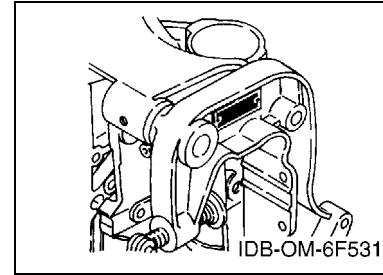

8. Números de serie del motor

Modelo	N° de serie	Modelo	N° de serie
E40G	6F6K-1033228	E40J	6J4K-1014119

9. Códigos de color aplicables

Abreviatura	Nombre de color	Código de color
DBNM2	DARK BLUISH GRAY METALLIC 2	004D

10. Información para la columna de cantidades

Columna N°	Nombre de la columna de cantidades	Modelo aplicable
1	E40M	E40GMH
2	40MH	E40JMH
3	E40W	E40GWH
4	40WH	E40JWH
5	40W	E40JW

CONTENTS

SHEET1/2

TOP COWLING	A4
CYLINDER & CRANKCASE	A5
CRANKSHAFT & PISTON	A7
INTAKE	B1
CARBURETOR	B3
FUEL	B4
STARTER	B6
GENERATOR	C1
ELECTRICAL 1	C2
ELECTRICAL 2	C4
ELECTRICAL 3	C5
STARTING MOTOR	C7
BOTTOM COWLING	D1
STEERING	D3
CONTROL 1	D5
CONTROL 2	D7
BRACKET 1	E1
BRACKET 2	E4
UPPER CASING 1	E6
UPPER CASING 2	E7
LOWER CASING & DRIVE 1	F1
LOWER CASING & DRIVE 2	F5
LOWER CASING & DRIVE 3	F7

INDEX

NUMERICAL INDEX	G1
-----------------------	----

SHEET2/2

LOWER CASING & DRIVE 3	A4*
LOWER CASING & DRIVE 4	A7*
FUEL TANK	B2*
STEERING GUIDE	B3*
REMOTE CONTROL BOX	B4*
REMOTE CONTROL ASSY	B5*
REPAIR KIT 1	C1*
REPAIR KIT 2	C3*
REPAIR KIT 3	C4*

INDEX

NUMERICAL INDEX	G1*
-----------------------	-----

CONTENIDO

PAGINA1/2

SOPORTE SUPERIOR	A4
CYLINDRO & CARTER	A5
CIGUENAL & PISTON	A7
ADMISION	B1
CARBURADOR	B3
COMBUSTIBLE	B4
ARRANQUE	B6
GENERADOR	C1
EQUIPO ELECTRICO 1	C2
EQUIPO ELECTRICO 2	C4
EQUIPO ELECTRICO 3	C5
MOTOR DE ARRANQUE	C7
CUBIERTA INFERIOR	D1
DIRECCION	D3
CONTROL 1	D5
CONTROL 2	D7
SOPORTE 1	E1
SOPORTE 2	E4
FUNDA SUPERIOR 1	E6
FUNDA SUPERIOR 2	E7
IMPULSOR E INFERIOR 1	F1
IMPULSOR E INFERIOR 2	F5
IMPULSOR E INFERIOR 3	F7

INDICE

INDICE NUMERICO	G1
-----------------------	----

PAGINA2/2

IMPULSOR E INFERIOR 3	A4*
IMPULSOR E INFERIOR 4	A7*
DEPOSITO DE COMBUSTIBLE	B2*
DIRECCIONGUIAR	B3*
CONTROL REMOTO COMPLETO	B4*
CONTROL REMOTO COMPL	B5*
ESTUCHE REPARATION 1	C1*
ESTUCHE REPARATION 2	C3*
ESTUCHE REPARATION 3	C4*

INDICE

INDICE NUMERICO	G1*
-----------------------	-----

FIG. 1 TOP COWLING

SOPORTE SUPERIOR

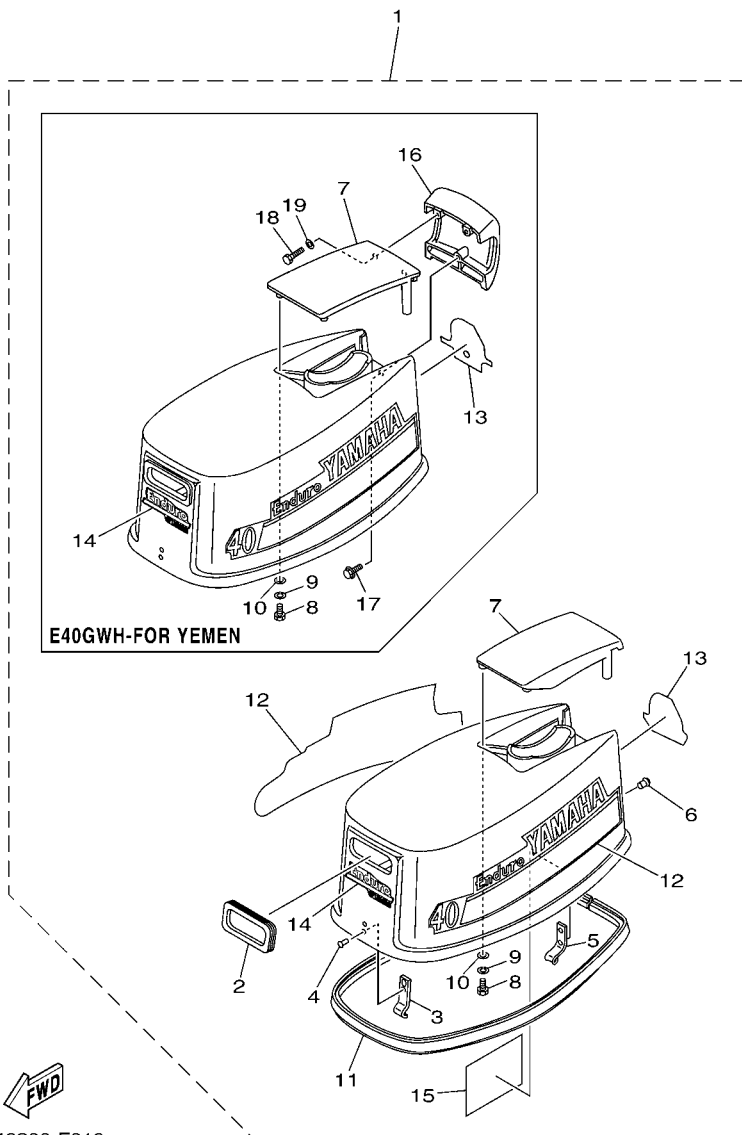

REF. NO.	PART NO. CODIGO Nº	DESCRIPTION DESCRIPCION	E40M	40MH	E40W	40WH	40W	REMARKS OBSERVACIONES
1	6J4-42610-J0-4D	TOP COWLING ASSY SOPORTE SUPERIOR COMPL.	1	1		1	1	EXCEPT E40G-YEM EXCEPT E40G-YEM
	6F6-42610-10-4D	TOP COWLING ASSY SOPORTE SUPERIOR COMPL.			1			E40G-FOR YEM E40G-FOR YEM
2	6A0-15761-00	.SEAL, RUBBER 1 .SELLO DE GOMA 1	1	1	1	1	1	
3	6E9-42651-01	.HOOK .GANCHO	1	1	1	1	1	
4	90266-04M04	.RIVET .REMACHE	2	2	2	2	2	
5	6F5-42652-01	.HOOK .GANCHO	1	1	1	1	1	
6	90266-04M01	.RIVET .REMACHE	2	2	2	2	2	
7	6F5-42613-01-4D	.MOLDING, AIR DUCT .MOLDURA CONDUCTO AIRE	1	1		1	1	EXCEPT E40G-YEM EXCEPT E40G-YEM
	6F6-42613-00-4D	.MOLDING, AIR DUCT .MOLDURA CONDUCTO AIRE			1			E40G-FOR YEM E40G-FOR YEM
8	97095-06016	.BOLT .PERNO	4	4	4	4	4	
9	92995-06100	.WASHER, SPRING .ARANDELA	4	4	4	4	4	
10	92995-06600	.WASHER .ARANDELA	4	4	4	4	4	
11	6F5-42615-00	.SEAL .SELLO	1	1	1	1	1	
12	6F5-W0070-K0	.GRAPHIC SET .JUEGO DE EMBLEMA	1	1	1	1	1	
13	6J4-42678-H0	.GRAPHIC, REAR .CALCAMONIA TRASERA	1	1		1	1	EXCEPT E40G-YEM EXCEPT E40G-YEM
	6F6-42678-00	.GRAPHIC, REAR .CALCAMONIA TRASERA			1			E40G-FOR YEM E40G-FOR YEM
14	69P-42677-H0	.GRAPHIC, FRONT .CALCAMONIA FRONTAL	1	1	1	1	1	
15	677-13437-0B	.MARK, CAUTION .MARKER	1	1	1	1	1	
16	6F6-42612-00	.AIR DUCT, TOP COWLING .DUCTO DE AIRE CUBIERTA				1		E40G-FOR YEM E40G-FOR YEM
17	90119-06121	.BOLT, WITH WASHER .TORNILLO CON ARANDELA				1		E40G-FOR YEM E40G-FOR YEM
18	97095-06025	.BOLT .PERNO				2		E40G-FOR YEM E40G-FOR YEM
19	92995-06600	.WASHER .ARANDELA				2		E40G-FOR YEM E40G-FOR YEM

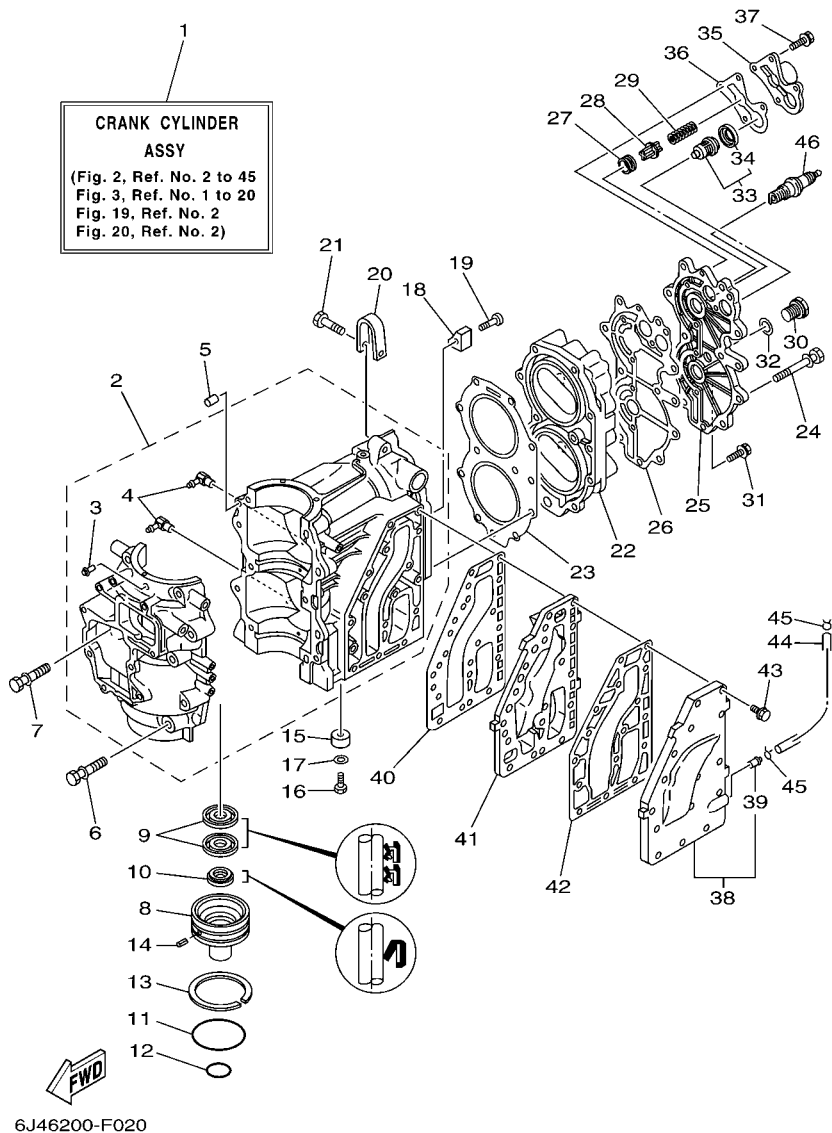

FIG. 2 CYLINDER & CRANKCASE CYLINDRO & CARTER

REF. NO.	PART NO. CODIGO Nº	DESCRIPTION DESCRIPCION	E40M	40MH	E40W	40WH	40W	REMARKS OBSERVACIONES
1	6F6-W0090-05-1S	CRANK CYLINDER ASSY BLOQUE MOTOR COMPLETO	1	1	1	1	1	
2	6F6-15100-02-1S	CRANKCASE ASSY CARTER COMPLETO	1	1	1	1	1	
3	624-14485-00	.PIPE, JOINT .TUBO DE UNION	1	1	1	1	1	
4	650-11370-01	.CHECK VALVE ASSY .VALVULA DE CONTROL COMPL.	2	2	2	2	2	
5	93608-12063	PIN, DOWEL PASADOR DE CLAVIJA	2	2	2	2	2	
6	90119-10005	BOLT, WITH WASHER TORNILLO CON ARANDELA	9	9	9	9	9	
7	90119-10028	BOLT, WITH WASHER TORNILLO CON ARANDELA	1	1	1	1	1	
8	6F5-15396-01-5B	HOUSING, OIL SEAL CAJA DE SELLO DE ACEITE	1	1	1	1	1	
9	93101-30M33	OIL SEAL SELLO ACEITE	2	2	2	2	2	
10	93104-16M01	OIL SEAL SELLO ACEITE	1	1	1	1	1	
11	93210-65M50	O-RING ANILLO O	1	1	1	1	1	
12	93210-22M02	O-RING ANILLO O	1	1	1	1	1	
13	93440-68M03	CIRCLIP SEGURO	1	1	1	1	1	
14	91690-30010	PIN, SPRING PASADOR DE RESORTE	1	1	1	1	1	
15	676-45251-00	ANODE CATODE	1	1	1	1	1	
16	97095-06016	BOLT PERNO	1	1	1	1	1	
17	92995-06600	WASHER ARANDELA	1	1	1	1	1	
18	676-11325-00	ANODE ANODO	1	1	1	1	1	
19	90141-06M00	SCREW, COUNTERSUNK TORNILLO RANURADO	1	1	1	1	1	
20	6F5-11119-00	HANGER, ENGINE SOPORTE DEL MOTOR	1	1	1	1	1	
21	90101-08001	BOLT TORNILLO	1	1	1	1	1	
22	6F6-11111-00-1S	HEAD, CYLINDER 1 CULATA CILINDRO 1	1	1	1	1	1	
23	6F5-11181-A1	GASKET, CYLINDER HEAD 1 JUNTA, DE CULATA 1	1	1	1	1	1	
24	90119-08MA5	BOLT, WITH WASHER TORNILLO CON ARANDELA	11	11	11	11	11	
25	6F6-11191-00-1S	COVER, CYLINDER HEAD 1 TAPA CULATA DE CILINDRO 1	1	1	1	1	1	
26	6F6-11193-A1	GASKET, HEAD COVER 1 EMPAQUE	1	1	1	1	1	
27	90480-18065	GROMMET TAPON	1	1	1	1	1	

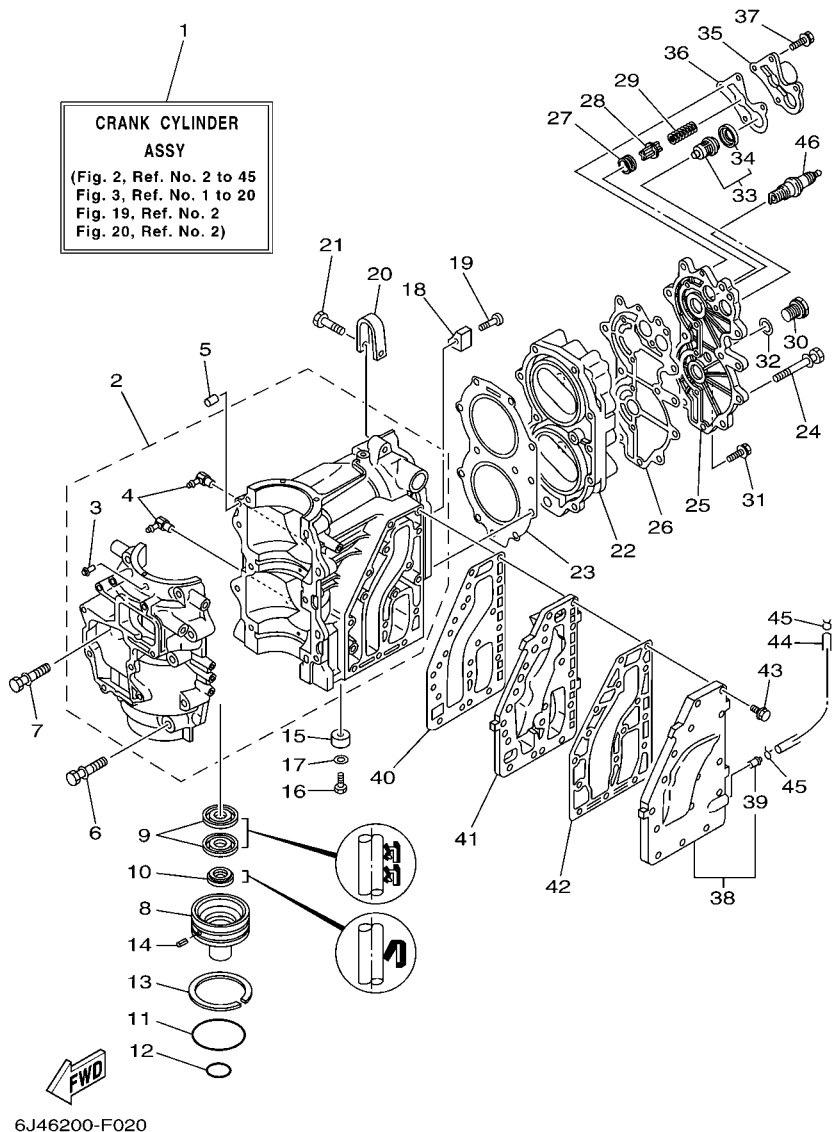
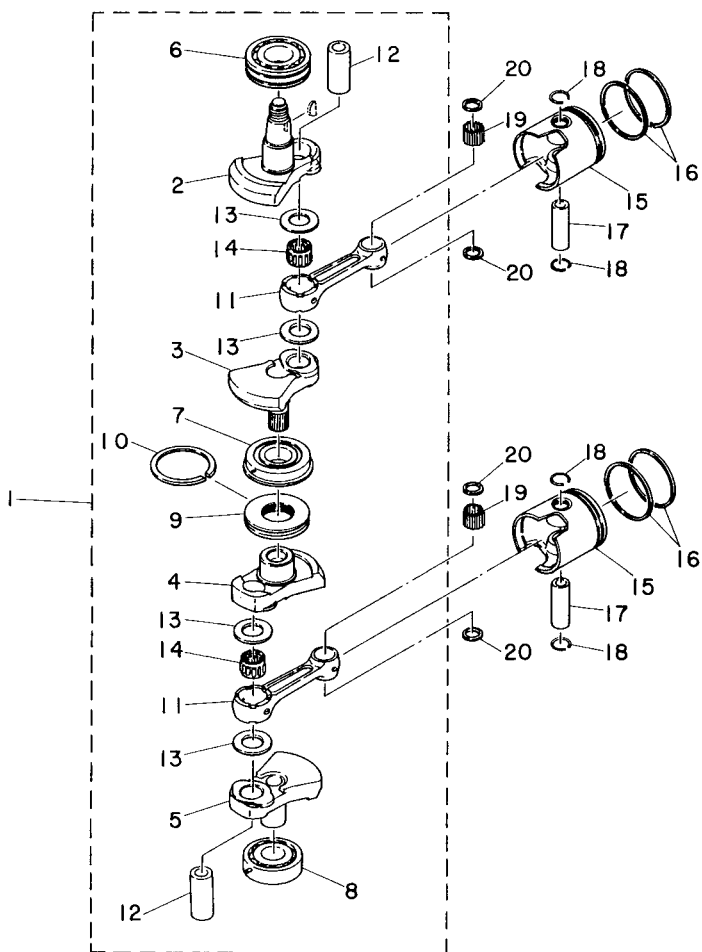

FIG. 2 CYLINDER & CRANKCASE CYLINDRO & CARTER

REF. NO.	PART NO. CODIGO Nº	DESCRIPTION DESCRIPCION	E40M	40MH	E40W	40WH	40W	REMARKS OBSERVACIONES
28	663-12416-00	VALVE, PRESSURE CONTROL VALVULA DE CONTROL DE PRESION	1	1	1	1	1	
29	90501-14M02	SPRING, COMPRESSION RESORTE DE COMPRESION	1	1	1	1	1	
30	90340-14036	PLUG, STRAIGHT SCREW TORNILLO, DE DRENAJE	1	1	1	1	1	
31	90119-06MA3	BOLT, WITH WASHER TORNILLO CON ARANDELA	4	4	4	4	4	
32	90430-14115	GASKET JUNTA	1	1	1	1	1	
33	6F5-12411-03	THERMOSTAT TERMOSTAT	1	1	1	1	1	
34	6E5-12412-00	.SEAL, THERMOSTAT .SELLO TERMOSTATO	1	1	1	1	1	
35	6E9-12413-00-1S	COVER, THERMOSTAT CUBIERTA TERMOSTATO	1	1	1	1	1	
36	6E9-12414-A1	GASKET, COVER EMPAQUE	1	1	1	1	1	
37	90119-06MA4	BOLT, WITH WASHER TORNILLO CON ARANDELA	4	4	4	4	4	
38	6F5-41113-01-1S	OUTER COVER, EXHAUST CUBOERTA EXTERIOR DE ESCAPE	1	1	1	1	1	
39	650-24378-00	.PIPE, JOINT 4 .TUBO DE UNION 4	1	1	1	1	1	
40	6F5-41112-A0	GASKET, EXHAUST INNER COVER EMPAQUE	1	1	1	1	1	
41	6F5-41111-01-1S	INNER COVER, EXHAUST CUBIERTA INTERIOR DE ESCAPE	1	1	1	1	1	
42	6F5-41114-A0	GASKET, EXHAUST OUTER COVER EMPAQUE	1	1	1	1	1	
43	90119-06MA3	BOLT, WITH WASHER TORNILLO CON ARANDELA	16	16	16	16	16	
44	90445-09M37	HOSE (L240) TUBO (L240)	1	1	1	1	1	
45	90467-08004	CLIP PRESILLA	2	2	2	2	2	
46	94702-00040	PLUG, SPARK (NGK B7HS) BUJIA (NGK B7HS)	2	2	2	2	2	EXCEPT E40J-CHN EXCEPT E40J-CHN
	94702-00272	PLUG, SPARK (NGK BR7HS) BUJIA (NGK BR7HS)		2		2	2	E40J-FOR CHN E40J-FOR CHN

FIG. 3 CRANKSHAFT & PISTON

CIGUENAL & PISTON



6J40200-4030

REF. NO.	PART NO. CODIGO N°	DESCRIPTION DESCRIPCION	E40M	40MH	E40W	40WH	40W	REMARKS OBSERVACIONES
1	6F6-11400-02	CRANKSHAFT ASSY CIGUENAL COMPLETO	1	1	1	1	1	
2	6F5-11412-11	.CRANK 1 .MANIVELA 1	1	1	1	1	1	
3	6F5-11422-11	.CRANK 2 .MANIVELA 2	1	1	1	1	1	
4	6F5-11432-11	.CRANK 3 .MANIVELA 3	1	1	1	1	1	
5	6F5-11442-11	.CRANK 4 .MANIVELA 4	1	1	1	1	1	
6	93306-307U0	.BEARING .COJINETE	1	1	1	1	1	
7	93332-000UE	.BEARING .COJINETE	1	1	1	1	1	
8	93306-306U2	.BEARING .COJINETE	1	1	1	1	1	
9	6F5-11515-00	.SEAL, LABYRINTH 1 .SELLO LABERINTO 1	1	1	1	1	1	
10	93440-68M03	.CIRCLIP .SEGURO	1	1	1	1	1	
11	6F5-11651-00	.ROD, CONNECTING .BIELA	2	2	2	2	2	
12	6F5-11681-00	.PIN, CRANK 1 .PASADOR MANIVELA 1	2	2	2	2	2	
13	90209-27012	.WASHER .ARANDELA DE SEPARACION	4	4	4	4	4	
14	93310-727V7	.BEARING .COJINETE DE RODILLOS	2	2	2	2	2	
15	6F6-11631-00-95	PISTON (STD) PISTON (NORMA)	2	2	2	2	2	
	6F6-11635-00	PISTON (0.25MM O/S)	2	2	2	2	2	AP
	6F6-11636-00	PISTON (0.50MM O/S)	2	2	2	2	2	AP
	6F6-11636-00	PISTON (0.50MM O/S)	2	2	2	2	2	AP
16	6F5-11610-00	PISTON RING SET (STD) JUEGO DE AROS (NORMA)	2	2	2	2	2	
	6F5-11610-10	PISTON RING SET (0.25MM O/S) JUEGO DE AROS (0.25MM O/S)	2	2	2	2	2	AP
	6F5-11610-20	PISTON RING SET (0.50MM O/S) JUEGO DE AROS (0.50MM O/S)	2	2	2	2	2	AP
17	6F5-11633-00	PIN, PISTON PASADOR, PISTON	2	2	2	2	2	
18	663-11634-00	CLIP, PISTON PIN PRESILLA, BULON DE PISTON	4	4	4	4	4	
19	93603-21111	PIN, DOWEL PASADOR DE CLAVIJA	56	56	56	56	56	
20	90201-20417	WASHER, PLATE ARANDELA PLANA	4	4	4	4	4	

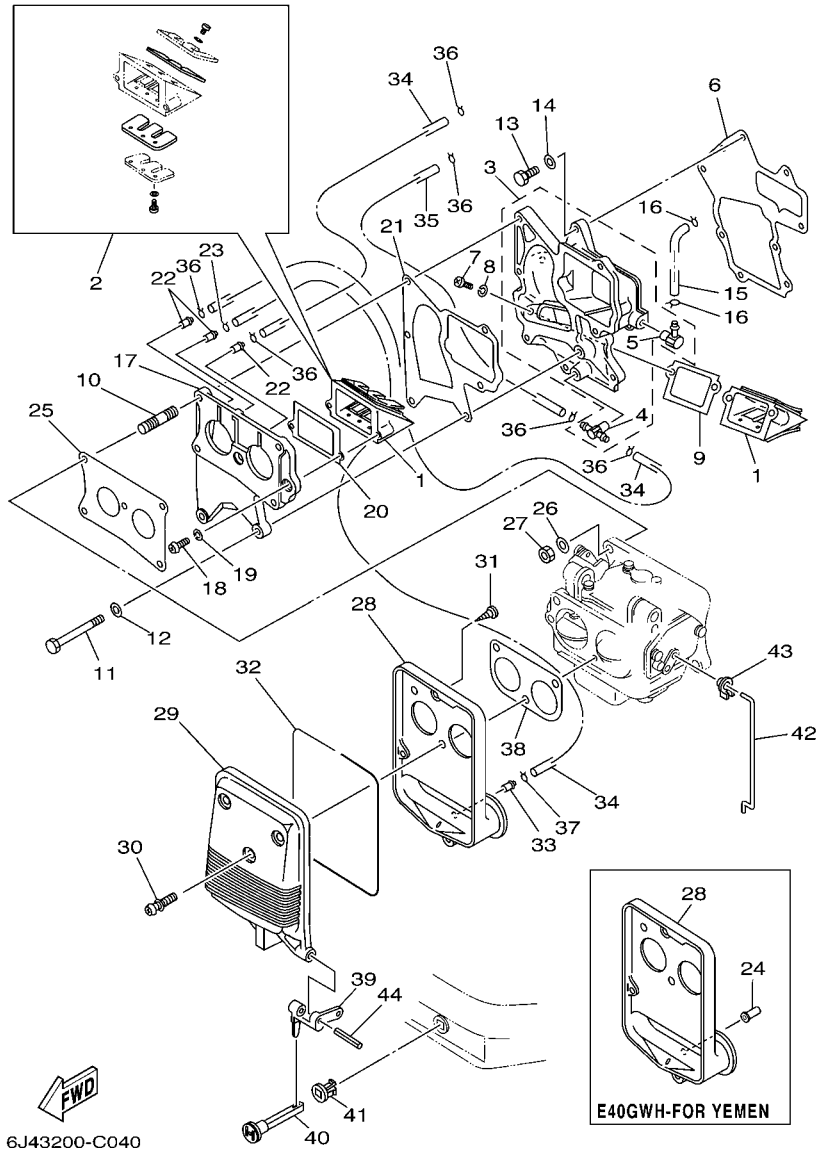

FIG. 4 INTAKE

ADMISION

REF. NO.	PART NO. CODIGO Nº	DESCRIPTION DESCRIPCION	E40M	40MH	E40W	40WH	40W	REMARKS OBSERVACIONES
1	6F6-13610-00	REED VALVE ASSY VALVULA DE LAMINAS COMPLETA	2	2	2	2	2	
2	692-W0004-00	.REED SET .JUEGO DE VALVULAS DE LENGUETA	1	1	1	1	1	
3	6F6-13641-00-1S	MANIFOLD 1 MULTIPLE 1	1	1	1	1	1	
4	6F6-11370-01	.CHECK VALVE ASSY .VALVULA DE CONTROL COMPL.	1	1	1	1	1	
5	650-11370-01	.CHECK VALVE ASSY .VALVULA DE CONTROL COMPL.	1	1	1	1	1	
6	6F5-13646-A2	GASKET, MANIFOLD 2 EMPAQ. DE MULTIPLE 2	1	1	1	1	1	
7	97880-05014	SCREW, PAN HEAD TORNILLO DE CABEZA CON PLANA	2	2	2	2	2	
8	92990-05100	WASHER, SPRING ARANDELA PLANA	2	2	2	2	2	
9	6F5-13621-A1	GASKET, VALVE SEAT JUNTA, DE VALV.DE EMPAQUE	1	1	1	1	1	
10	90116-06M17	BOLT, STUD ESPARRAGO	4	4	4	4	4	
11	97013-06065	BOLT PERNO	2	2	2	2	2	
12	92903-06600	WASHER, PLATE RONDANA SENCILLA	2	2	2	2	2	
13	97013-06025	BOLT PERNO	7	7	7	7	7	
14	92903-06600	WASHER, PLATE RONDANA SENCILLA	7	7	7	7	7	
15	90445-07254	HOSE (L118) TUBO (L118)	1	1	1	1	1	
16	90467-06016	CLIP PRESILLA	2	2	2	2	2	
17	6F6-13643-01-1S	COVER, MANIFOLD CUBIERTA DE COLECTOR	1	1	1	1	1	
18	97880-05014	SCREW, PAN HEAD TORNILLO DE CABEZA CON PLANA	2	2	2	2	2	
19	92990-05100	WASHER, SPRING ARANDELA PLANA	2	2	2	2	2	
20	6F5-13621-A1	GASKET, VALVE SEAT JUNTA, DE VALV.DE EMPAQUE	1	1	1	1	1	
21	6F5-13645-A1	GASKET, MANIFOLD 1 EMPAQUE	1	1	1	1	1	
22	624-14485-00	PIPE, JOINT TUBO DE UNION	3	3	3	3	3	
23	90467-06016	CLIP PRESILLA	1	1		1	1	EXCEPT E40G-YEM EXCEPT E40G-YEM
24	647-14395-60	CAP, OVERFLOW PIPE TAPA DE TUBO REBOSAMIENTO			1			E40G-FOR YEM E40G-FOR YEM
25	6F5-14198-A1	GASKET EMPAQUE	1	1	1	1	1	
26	92995-06600	WASHER ARANDELA	4	4	4	4	4	
27	95380-06600	NUT, HEXAGON TUERCA	4	4	4	4	4	

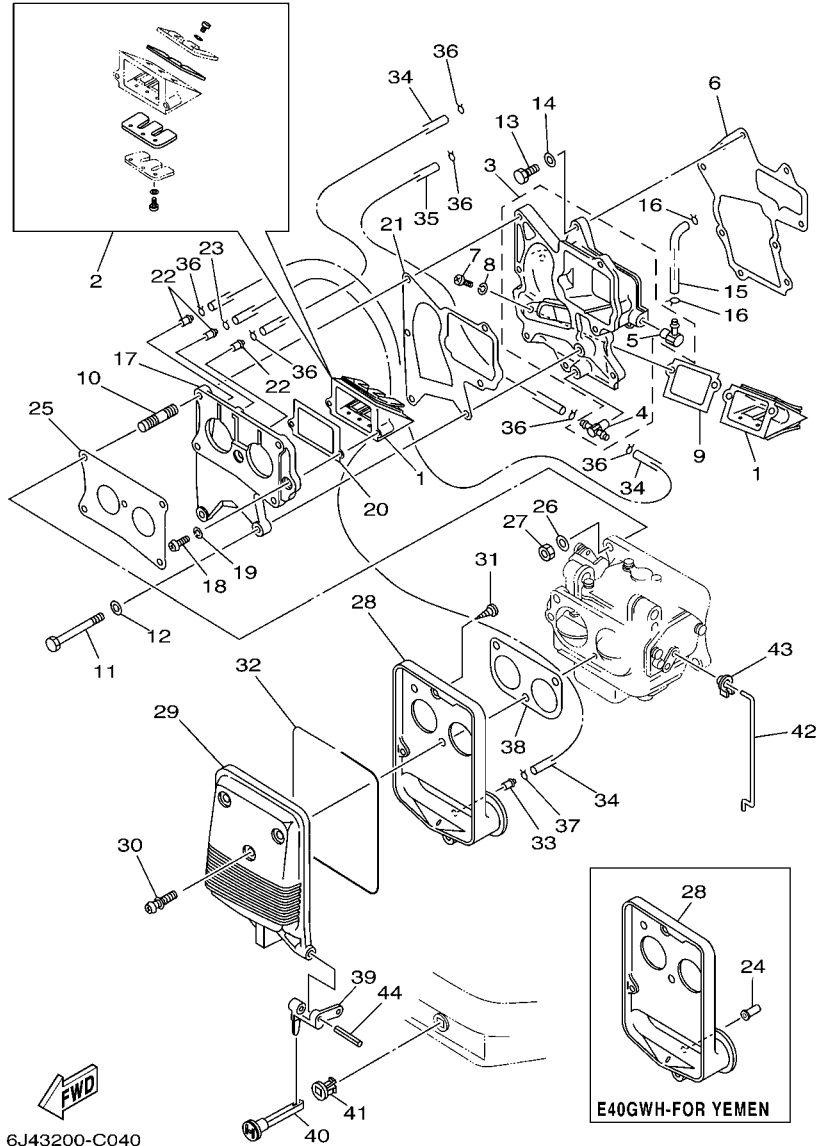

FIG. 4 INTAKE

ADMISION

REF. NO.	PART NO. CODIGO Nº	DESCRIPTION DESCRIPCION	E40M	40MH	E40W	40WH	40W	REMARKS OBSERVACIONES
28	6F5-14417-00	COVER 1 CUBIERTA 1	1	1	1	1	1	
29	6F5-14418-00	COVER 2 CUBIERTA 2	1	1	1	1	1	
30	90159-06M01	SCREW, WITH WASHER TORNILLO CON VALONA	3	3	3	3	3	
31	97780-50716	SCREW, TAPPING TORNILLO DE CABEZA DE CONO ACH	4	4	4	4	4	
32	6F5-14476-00	SEAL SELLO	1	1	1	1	1	
33	624-14485-00	PIPE, JOINT TUBO DE UNION	1	1		1	1	EXCEPT E40G-YEM EXCEPT E40G-YEM
34	90445-07240	HOSE (L330) TUBO (L330)	3	3		3	3	EXCEPT E40G-YEM EXCEPT E40G-YEM
	90445-07240	HOSE (L330) TUBO (L330)			2			E40G-FOR YEM E40G-FOR YEM
35	90445-07M24	HOSE (L240) TUBO (L240)	1	1	1	1	1	
36	90467-06016	CLIP PRESILLA	6	6	6	6	6	
37	90467-06016	CLIP PRESILLA	1	1		1	1	EXCEPT E40G-YEM EXCEPT E40G-YEM
38	6F5-14483-00	GASKET EMPAQUE	1	1	1	1	1	
39	6F5-41252-00	LEVER, CHOKE 1 PALANCA AHOGADOR 1	1	1	1	1	1	
40	682-41271-00	KNOB, CHOKE PERILLA AHOGADOR	1	1	1	1	1	
41	689-41273-00	GROMMET TAPON PROTECTOR	1	1	1	1	1	
42	6F6-41256-00	ROD, CHOKE 1 VARILLA DE AHOGADOR	1	1	1	1	1	
43	661-41262-02	JOINT, CHOKE LEVER CONECTOR DE AHOGADOR	2	2	2	2	2	
44	91690-40032	PIN, SPRING PASADOR DE RESORTE	1	1	1	1	1	

FIG. 5 CARBURETOR

CARBURADOR

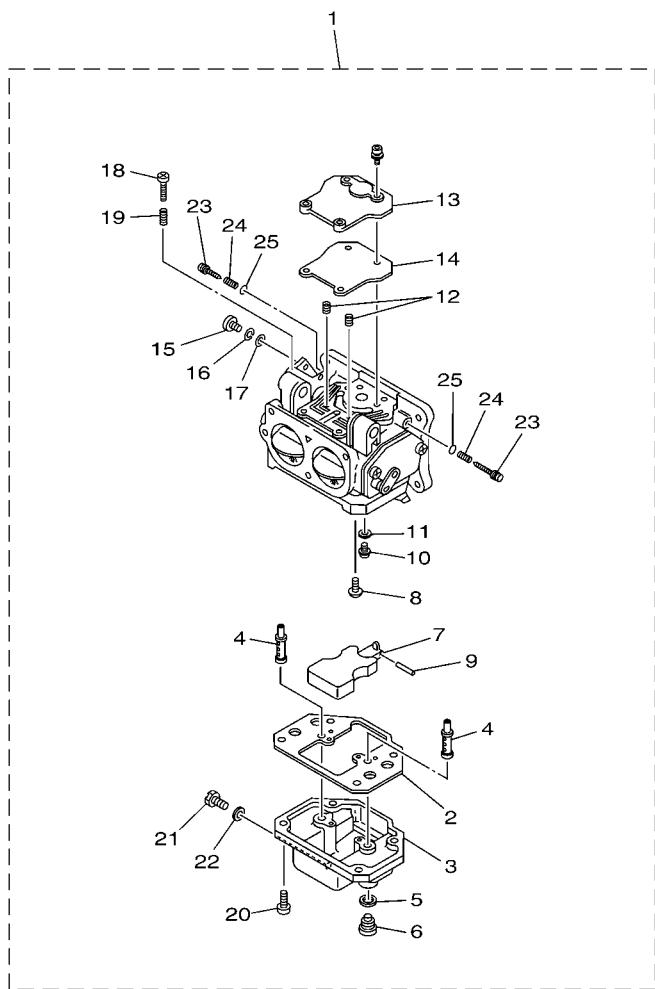

6J46200-F050

REF. NO.	PART NO. CODIGO Nº	DESCRIPTION DESCRIPCION	E40M	40MH	E40W	40WH	40W	REMARKS OBSERVACIONES
1	6F6-14301-06	CARBURETOR ASSY 1 CARBURADOR COMPLETO 1	1	1	1	1		E40G/E40J E40G/E40J
	6J4-14301-05	CARBURETOR ASSY 1 CARBURADOR COMPLETO 1					1	E40J E40J
2	6F5-14384-00	.GASKET, FLOAT CHAMBER .EMPAQUE DE CAMARA DE BOIA	1	1	1	1	1	
3	6F6-14381-00	.BODY, FLOAT CHAMBER .CUERPO DE CAMARA DE BOIA	1	1	1	1	1	
4	6F6-14341-00	.NOZZLE, MAIN .BOQUILLA PRINCIPAL	2	2	2	2	2	
5	1J2-14398-00	.GASKET .EMPAQUE	2	2	2	2	2	
6	677-14343-75	.JET, MAIN (#150) .INYECTOR PRINCIPAL (#150)	2	2	2	2	2	
7	6F6-14385-00	.FLOAT .BOIA	1	1	1	1	1	
8	98980-04006	.SCREW, BIND .TORNILLO DE LIGAR	1	1	1	1	1	
9	6E5-14386-01	.PIN, FLOAT .PASADOR DE BOIA	1	1	1	1	1	
10	6F5-14390-21	.NEEDLE VALVE ASSY .VALVULA DE AGUJA COMPLETA	1	1	1	1	1	
11	367-14195-00	.GASKET .ARANDELA DE VALVULA DE AGUJA	1	1	1	1	1	
12	647-14342-45	.JET, PILOT (# 90) .ESPREA DE PILOTO (# 90)	2	2	2	2	2	
13	6F6-14383-00	.PLATE .TORNILLO DE DRENAJE	1	1	1	1	1	
14	6F5-14398-00	.GASKET .EMPAQUE	1	1	1	1	1	
15	97890-05010	.SCREW, PAN HEAD .TORNILLO	1	1	1	1	1	
16	92990-05100	.WASHER, SPRING .ARANDELA PLANA	1	1	1	1	1	
17	92990-05600	.WASHER, PLATE .ARANDELA PLANA	1	1	1	1	1	
18	650-14321-01	.SCREW, THROTTLE .TORNILLO DE OBTURADOR	1	1	1	1	1	
19	647-14334-00	.SPRING .RESORTE DE AJUSTADOR DE AIRE	1	1	1	1	1	
20	97603-05117	.SCREW, PAN HEAD WITH WASHER .TORNILLO	4	4	4	4	4	
21	6F5-14383-10	.SCREW, DRAIN .TORNILLO DE DRENAJE	1	1	1	1	1	
22	6F6-14398-00	.GASKET .EMPAQUE	1	1	1	1	1	
23	6F5-14323-01	.SCREW, AIR ADJUSTING .TORNILLO DE AJUSTE DE AIRE	2	2	2	2	2	
24	6F5-14334-01	.SPRING, AIR ADJUSTING .RESORTE DE AJUSTADOR DE AIRE	2	2	2	2	2	
25	5Y1-14397-00	.O-RING .ANILLO O	2	2	2	2	2	

FIG. 6 FUEL

COMBUSTIBLE

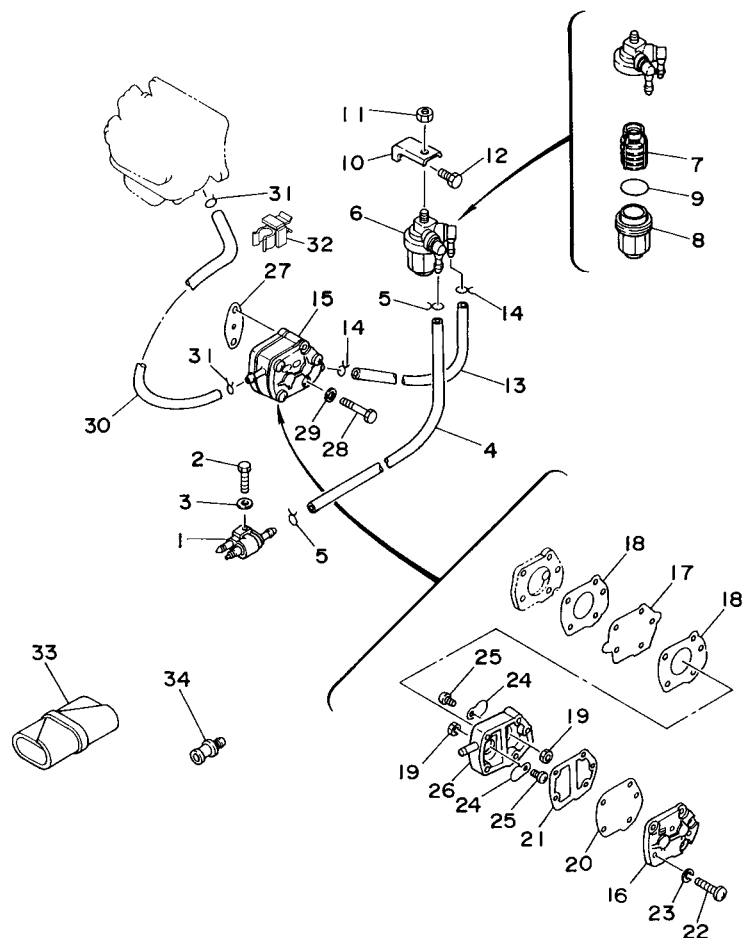

FWD
6J44200-D060

REF. NO.	PART NO. CODIGO Nº	DESCRIPTION DESCRIPCION	E40M	40MH	E40W	40WH	40W	REMARKS OBSERVACIONES
1	6G1-24304-02	FUEL PIPE JOINT COMP. 1 CONECTOR MANGUERA COMBUST.1	1	1	1	1	1	
2	97095-06025	BOLT PERNO	1	1	1	1	1	
3	92995-06600	WASHER ARANDELA	1	1	1	1	1	
4	90445-09226	HOSE (L390) TUBO (L390)	1	1	1	1	1	
5	90467-08004	CLIP PRESILLA	2	2	2	2	2	
6	61N-24560-00	FILTER ASSY FILTRO COMPLETO	1	1	1	1	1	
7	61N-24563-00	.ELEMENT, FILTER .ELEMENTO DEL FILTRO	1	1	1	1	1	
8	61N-24521-00	.CUP, FILTER .COPA DE FILTRO	1	1	1	1	1	
9	93210-32738	.O-RING .ANILLO O	1	1	1	1	1	
10	648-24566-02	BRACKET, FILTER SOPORTE DEL FILTRO	1	1	1	1	1	
11	95380-08600	NUT TUERCA	1	1	1	1	1	
12	97013-06014	BOLT PERNO	1	1	1	1	1	
13	90445-09090	HOSE (L185) TUBO (L185)	1	1	1	1	1	
14	90467-08004	CLIP PRESILLA	2	2	2	2	2	
15	692-24410-00	FUEL PUMP ASSY BOMBA DE COMBUSTIBLE COMPLETA	1	1	1	1	1	
16	6A0-24413-00	.BODY 2 .CUERPO 2	1	1	1	1	1	
17	692-24411-00	.DIAPHRAGM .DIAFRAGMA	1	1	1	1	1	
18	648-24434-01	.GASKET, BODY .EMPAQUE	2	2	2	2	2	
19	95380-03600	.NUT .TUERCA	2	2	2	2	2	
20	663-24411-00	.DIAPHRAGM .DIAFRAGMA	1	1	1	1	1	
21	648-24435-02	.GASKET, BODY 2 .EMPAQUE	1	1	1	1	1	
22	98503-05028	.SCREW, PAN HEAD .TORNILLO DE CABEZA DE CONO AC	3	3	3	3	3	
23	92990-05100	.WASHER, SPRING .ARANDELA PLANA	3	3	3	3	3	
24	6A0-24421-01	.VALVE, CHECK .VALVULA DE RETENCION	2	2	2	2	2	
25	6A0-14325-00	.SCREW, PAN HEAD .TORNILLO CABEZA REDONDA	2	2	2	2	2	
26	6A0-24412-02	.BODY 1 .CUERPO 1	1	1	1	1	1	
27	650-24431-A0	GASKET, FUEL PUMP 1 EMPAQUE BOMBA COMBUST 1	1	1	1	1	1	

B4

FIG. 6 FUEL

COMBUSTIBLE

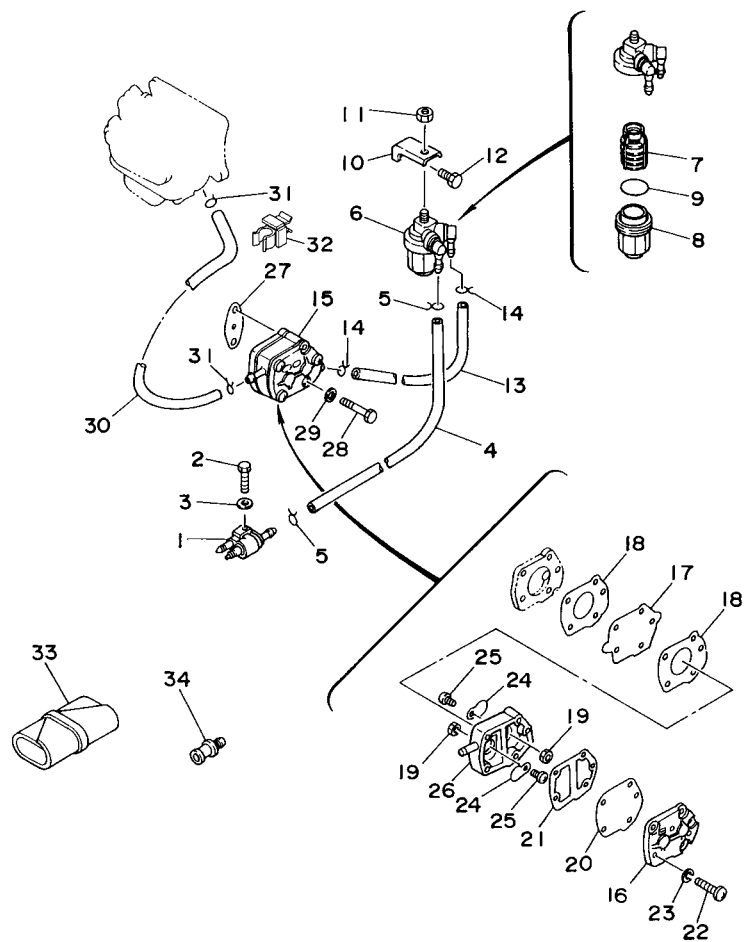

FWD
6J44200-D060

REF. NO.	PART NO. CODIGO Nº	DESCRIPTION DESCRIPCION						REMARKS OBSERVACIONES
			E40M	40MH	E40W	40WH	40W	
28	97095-06040	BOLT PERNO	2	2	2	2	2	
29	92995-06600	WASHER ARANDELA	2	2	2	2	2	
30	90445-09090	HOSE (L185) TUBO (L185)	1	1	1	1	1	
31	90467-08004	CLIP PRESILLA	2	2	2	2	2	
32	90464-07008	CLAMP BRIDA	1	1	1	1	1	
33	676-W2810-01	TOOL KIT JUEGO DE HERRAMIENTAS	1	1	1	1	1	
34	626-28193-01-94	PLUG, WATER CHECK TAPON DE CONTROL DE LA AGUA	1	1	1	1	1	AP D:15MM AP D:15MM

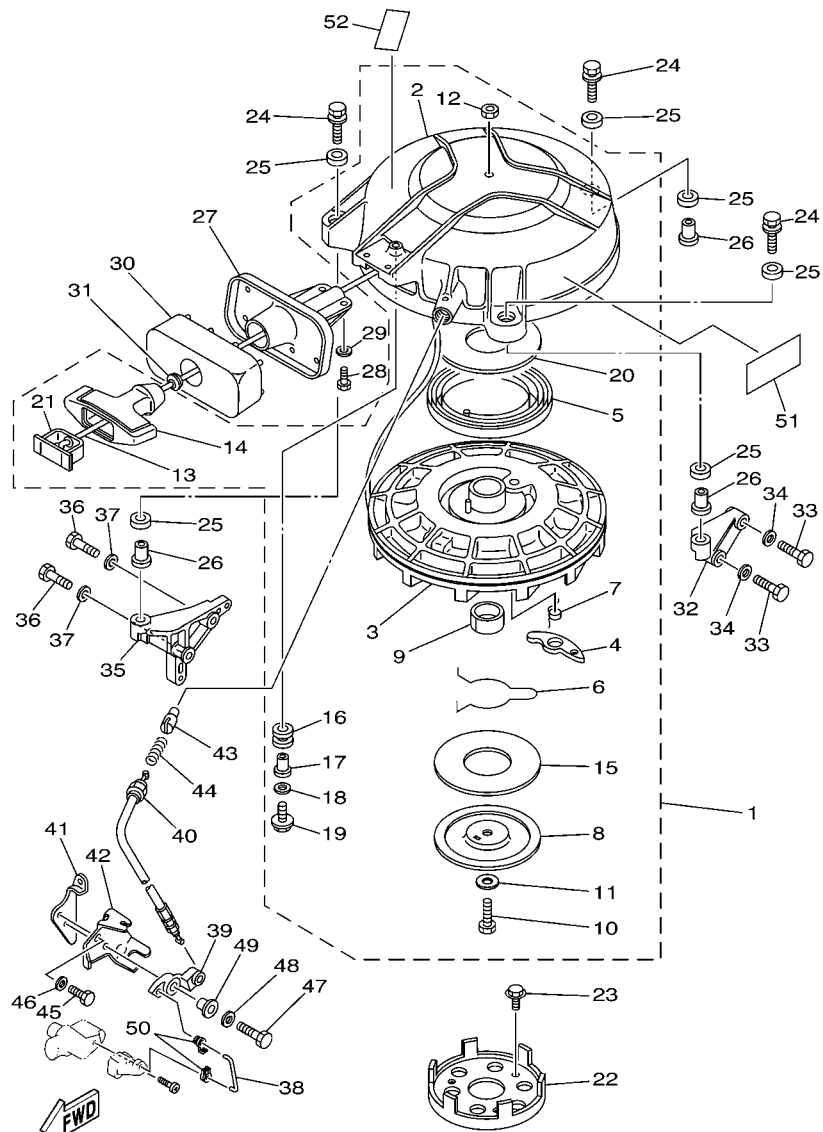

6J43200-C070

*1: CUT FROM 50M ROLLS, PART NO. 90890-44373, CUTTING LENGTH 1.9M

*1: CORTE DE UN RODILLO DE 50M , PARTS NUMERO 90890-44373, LARGO DEL CORTE 1.9M

FIG. 7 STARTER

ARRANQUE

REF. NO.	PART NO. CODIGO Nº	DESCRIPTION DESCRIPCION	E40M	40MH	E40W	40WH	40W	REMARKS OBSERVACIONES
1	6F5-W1571-03	STARTER ASSY ARRANQUE COMPLETO	1	1	1	1	1	
2	6F5-15711-02	.CASE, STARTER .CAJA DE ARRANQUE	1	1	1	1	1	
3	6F5-15714-03	.DRUM, SHEAVE .TAMBOR ROLDANA	1	1	1	1	1	
4	6F5-15741-01	.PAWL, DRIVE .TRINQUETE DE TRACCION	1	1	1	1	1	
5	6F5-15713-00	.SPRING, STARTER .RESORTE DE ARRANQUE	1	1	1	1	1	
6	6F5-15715-00	.SPRING, FRICTION .RESORTE PLACA DE TRACCION	1	1	1	1	1	
7	6F5-15734-01	.SPRING, RETURN .RESORTE DE RETORNO	1	1	1	1	1	
8	6F5-15716-01	.PLATE, DRIVE .PLACA DE TRACCION	1	1	1	1	1	
9	6F5-15754-00	.BUSH 2 .BUJE 2	1	1	1	1	1	
10	97013-08030	.BOLT .PERNO	1	1	1	1	1	
11	6F5-15726-01	.WASHER, FLAT .ARANDELA PLANA	1	1	1	1	1	
12	95303-08700	.NUT .TUERCA	1	1	1	1	1	
13	*	.WIRE (L:1900MM) .CABLE (L:1900MM)	1	1	1	1	1	*1 *1
14	689-15755-01	.HANDLE, STARTER .MANIJA DE ARRANQUE	1	1	1	1	1	
15	6F5-15764-00	.COLLAR 1 .COLLAR 1	1	1	1	1	1	
16	6F5-15752-00	.ROLLER, WIRE .RODILLO DE CUERDA	1	1	1	1	1	
17	6F5-15753-00	.BUSH .BUJE	1	1	1	1	1	
18	6F5-15791-00	.WASHER, LOCK .EMBLEMA	1	1	1	1	1	
19	6F5-15768-00	.BOLT .TORNILLO	1	1	1	1	1	
20	6F5-15739-00	.WASHER, THRUST .ARANDELA DE EMPUJE AXIAL	1	1	1	1	1	
21	6F5-15779-02	.COVER .CUBIERTA	1	1	1	1	1	
22	6F5-15723-01	PULLEY, STARTER POLEA DE ARRANQUE	1	1	1	1	1	
23	90105-08M10	BOLT, FLANGE TORNILLO	3	3	3	3	3	
24	90119-08M10	BOLT, WITH WASHER TORNILLO CON ARANDELA	3	3	3	3	3	
25	90385-12M04	BUSH BUJE	6	6	6	6	6	
26	90387-08M05	COLLAR ESPACIADOR	3	3	3	3	3	
27	6A0-15758-01-94	GUIDE, ROPE GUIA DE CUERDA	1	1	1	1	1	

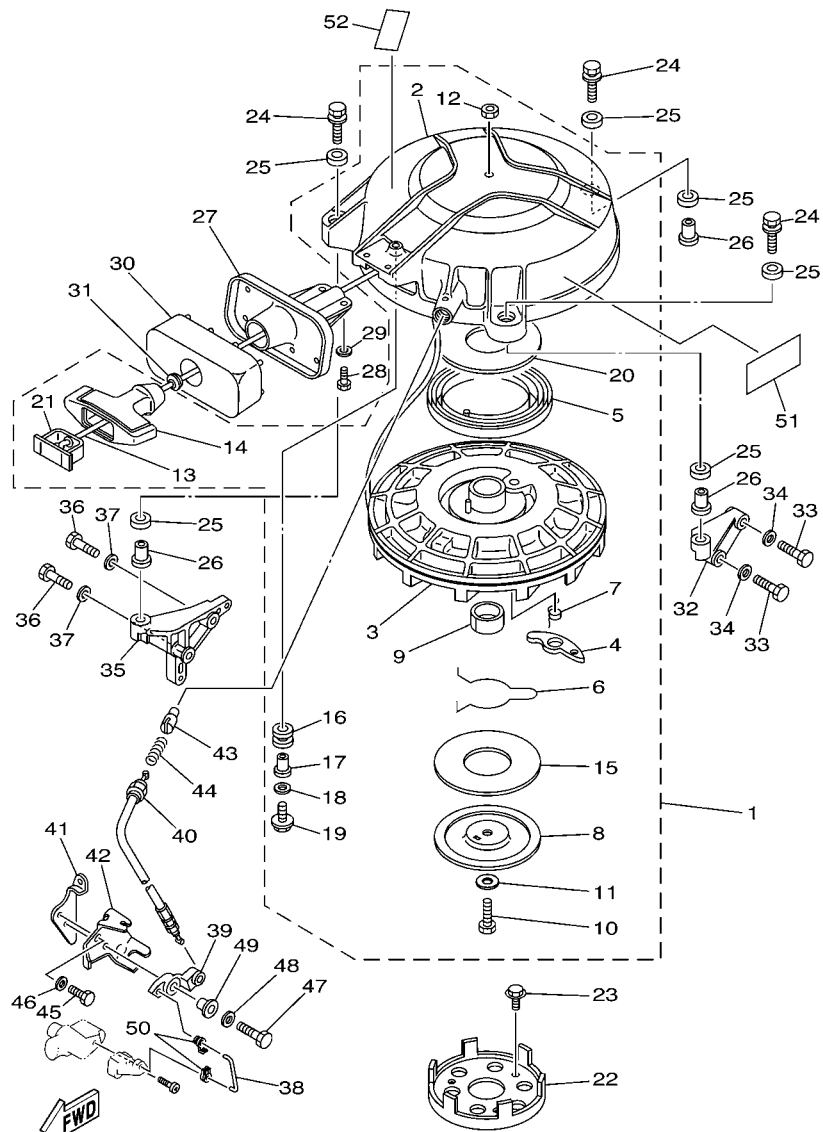

6J43200-C070

*1: CUT FROM 50M ROLLS, PART NO. 90890-44373, CUTTING LENGTH 1.9M
 *1: CORTE DE UN RODILLO DE 50M , PARTS NUMERO 90890-44373, LARGO DEL CORTE 1.9M

FIG. 7 STARTER

ARRANQUE

REF. NO.	PART NO. CODIGO Nº	DESCRIPTION DESCRIPCION	E40M	40MH	E40W	40WH	40W	REMARKS OBSERVACIONES
28	97095-06016	BOLT PERNO	2	2	2	2	2	
29	92995-06600	WASHER ARANDELA	2	2	2	2	2	
30	6A0-15762-01	SEAL, RUBBER 2 SELLO DE GOMA 2	1	1	1	1	1	
31	6A0-15789-00	DAMPER AMORTIGUADOR	1	1	1	1	1	
32	6F5-15771-00-94	STAY 1 SOPORTE 1	1	1	1	1	1	
33	97013-08035	BOLT PERNO	2	2	2	2	2	
34	92903-08600	WASHER, PLATE RONDANA SENCILLA	2	2	2	2	2	
35	6F5-15772-00-94	STAY 2 SOPORTE 2	1	1	1	1	1	
36	97013-08035	BOLT PERNO	2	2	2	2	2	
37	92903-08600	WASHER, PLATE RONDANA SENCILLA	2	2	2	2	2	
38	6F5-15747-00	LINK ESLABON	1	1	1	1	1	
39	6F5-15746-00	ARM BRAZO	1	1	1	1	1	
40	6F5-15770-00	CABLE COMP., STARTER STOP CABLECOMPL DE SEGURO ARRANQUE	1	1	1	1	1	
41	6F5-15773-00	STAY 3 SOPORTE 3	1	1	1	1	1	
42	6F5-15774-00	STAY 4 SOPORTE 4	1	1	1	1	1	
43	656-15748-00	PLUNGER, STARTER STOP EMBOLO SEGURO DE ARRANQUE	1	1	1	1	1	
44	90501-10227	SPRING, COMPRESSION RESORTE DE COMPRESION	1	1	1	1	1	
45	97095-06016	BOLT PERNO	1	1	1	1	1	
46	92995-06600	WASHER ARANDELA	1	1	1	1	1	
47	97095-06030	BOLT PERNO	1	1	1	1	1	
48	92995-06600	WASHER ARANDELA	1	1	1	1	1	
49	90387-06M29	COLLAR ESPACIADOR	1	1	1	1	1	
50	661-41262-02	JOINT, CHOKE LEVER CONECTOR DE AHOGADOR	2	2	2	2	2	
51	6F6-14488-00	LABEL, CAUTION ETIQUETA PRECAUCION	1	1		1	1	EXCEPT E40G-YEM
	6F6-14488-10	LABEL, CAUTION ETIQUETA PRECAUCION			1			EXCEPT E40G-YEM
52	6A1-83625-41	MARK 5 MARCA 5	1	1	1	1	1	E40G-FOR YEM
								E40G-FOR YEM

FIG. 8 GENERATOR

GENERADOR

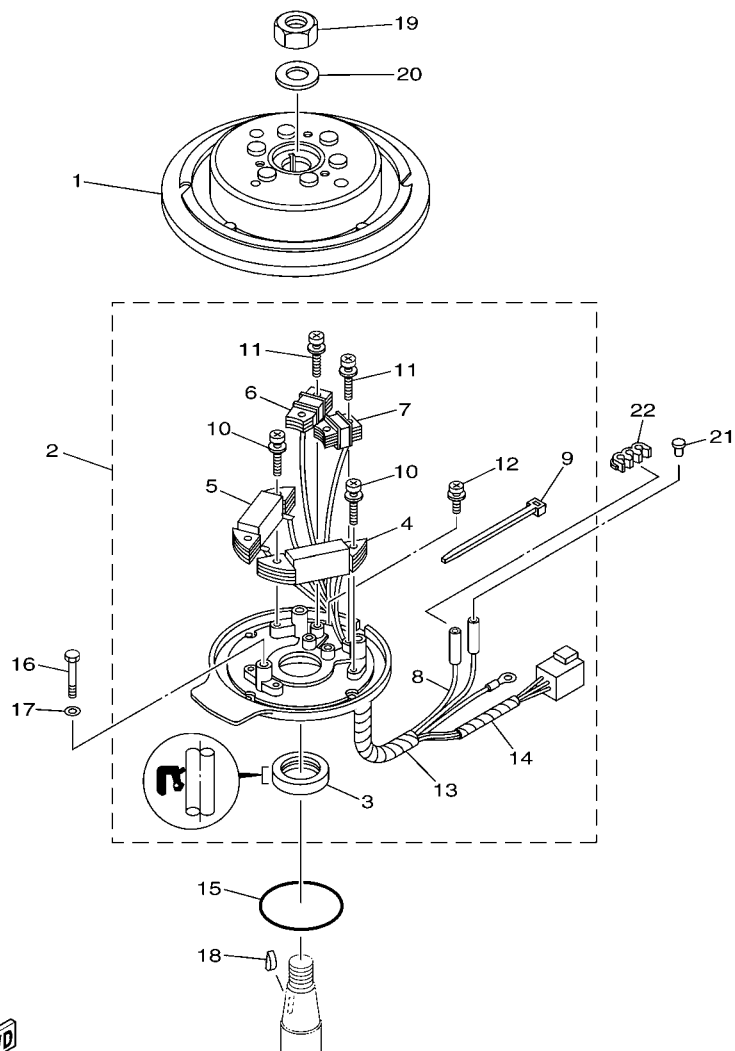

6J44200-D080

REF. NO.	PART NO. CODIGO Nº	DESCRIPTION DESCRIPCION	E40M	40MH	E40W	40WH	40W	REMARKS OBSERVACIONES
1	6F5-85550-G0	ROTOR ASSY ROTOR COMPLETO	1	1				
	6F6-85550-B0	ROTOR ASSY ROTOR COMPLETO			1	1	1	
2	6F5-85560-B0	BASE ASSY CONJUNTO BASE	1	1	1	1	1	
3	93102-35M18	.OIL SEAL .SELLO ACEITE	1	1	1	1	1	
4	6F5-85520-10	.COIL, CHARGE .BOBINA DE CARGA	1	1	1	1	1	
5	6F5-85533-10	.COIL, LIGHTING .BOBINA DE LUZ	1	1	1	1	1	
6	6F5-85580-10	.COIL, PULSER .BOBINA DE PULSACION	1	1	1	1	1	
7	6F5-85580-20	.COIL, PULSER .BOBINA DE PULSACION	1	1	1	1	1	
8	6F5-85515-10	.LEAD WIRE ASSY .CABLE CONDUCTOR COMPLETO	1	1	1	1	1	
9	6F5-81328-00	.CLAMP .GRAMPA	1	1	1	1	1	
10	90159-05040	.SCREW, WITH WASHER .TORNILLO CON VALONA	4	4	4	4	4	
11	90159-04063	.SCREW, WITH WASHER .TORNILLO CON VALONA	4	4	4	4	4	
12	90159-04035	.SCREW, WITH WASHER .TORNILLO CON VALONA	1	1	1	1	1	
13	6F5-85597-J0	.TUBE 1 .TUBO 1	1	1	1	1	1	
14	6F5-85597-H0	.TUBE 1 .TUBO 1	1	1	1	1	1	
15	93210-75M51	O-RING ANILLO O	1	1	1	1	1	
16	97095-06040	BOLT PERNO	3	3	3	3	3	
17	92995-06600	WASHER ARANDELA	3	3	3	3	3	
18	90280-05015	KEY, WOODRUFF CUNA WOODRUFF	1	1	1	1	1	
19	90170-20137	NUT TUERCA	1	1	1	1	1	
20	90201-21M18	WASHER, PLATE ARANDELA PLANA	1	1	1	1	1	
21	703-82119-00	COVER, LEAD WIRE CUBIERTA DE CABLE CONDUCTOR	2	2				
22	90468-07179	CLIP PRESILLA	1	1	1	1	1	

C1

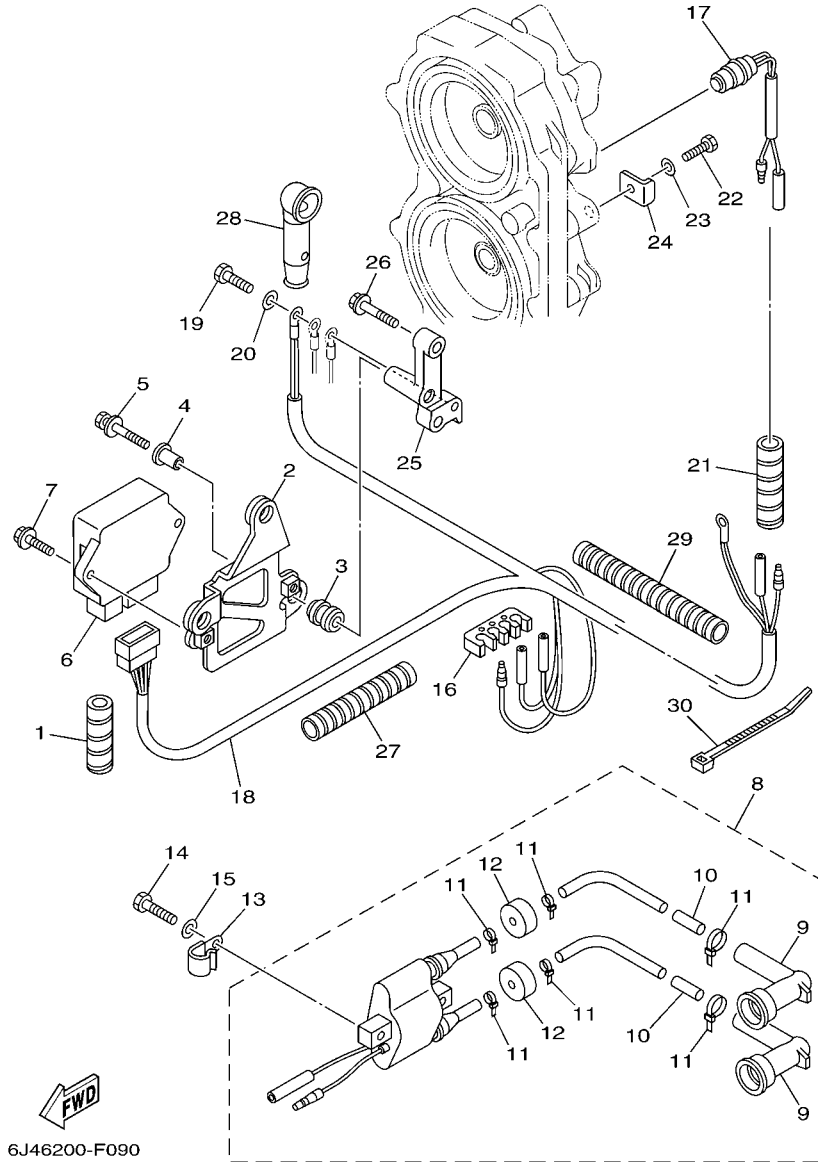

FIG. 9 ELECTRICAL 1

EQUIPO ELECTRICO 1

REF. NO.	PART NO. CODIGO Nº	DESCRIPTION DESCRIPCION	E40M	40MH	E40W	40WH	40W	REMARKS OBSERVACIONES
1	90446-10M02	HOSE TUBO RESEIRADERO	1	1	1	1	1	
2	6F5-85542-10	BRACKET SOPORTE	1	1	1	1	1	
3	61N-82317-00	DAMPER, IGNITION COIL AMORTIGUADOR BOBINA ENCENDIDO	3	3	3	3	3	
4	90387-06119	COLLAR ESPACIADOR	3	3	3	3	3	
5	90119-06M65	BOLT, WITH WASHER TORNILLO CON ARANDELA	3	3	3	3	3	
6	6F6-85540-01	C.D.I. UNIT ASSY UNIDAD C.D.I. COMPLETA	1	1	1	1	1	
7	90109-06M86	BOLT PERNO	2	2	2	2	2	
8	6F6-85530-01	IGNITION COIL ASSY BOBINA DE IGNICION COMPLETO	1	1	1	1	1	
9	62E-82371-11	.CAP. PLUG .TAPON DE BUJIA COMPLT	2	2	2	2	2	
10	62E-8231X-00	.TERMINAL 1 .TERMINAL 1	2	2	2	2	2	
11	90465-11M10	.CLAMP .BRIDA	6	6	6	6	6	
12	90480-25161	.GROMMET .TAPON	2	2	2	2	2	
13	90465-08M07	CLAMP BRIDA	1	1	1	1	1	
14	97095-06025	BOLT PERNO	2	2	2	2	2	
15	92995-06600	WASHER ARANDELA	2	2	2	2	2	
16	90464-07M06	CLAMP BRIDA	1	1	1	1	1	
17	688-82560-10	THERMO SWITCH ASSY INTER. DE TERMO	1	1	1	1	1	
18	6F5-82590-20	WIRE HARNESS ASSY CONJUNTO DE CABLES	1	1				
19	97095-06016	BOLT PERNO	1	1				
20	92995-06600	WASHER ARANDELA	1	1				
21	90446-10M01	HOSE (L60) TUBO (L60)	1	1	1	1	1	
22	97095-06016	BOLT PERNO	1	1	1	1	1	
23	92995-06600	WASHER ARANDELA	1	1	1	1	1	
24	6F5-82588-00	PLATE PLACA	1	1	1	1	1	
25	6F5-81948-00	BRACKET SOPORTE	1	1				
26	90105-08M35	BOLT, FLANGE TORNILLO	2	2				
27	6N7-83557-00	TUBE (I.DIA:22MM) ENCHUFE DE ACEITE (I.DIA:22MM)	1	1				

FIG. 9 ELECTRICAL 1

EQUIPO ELECTRICO 1

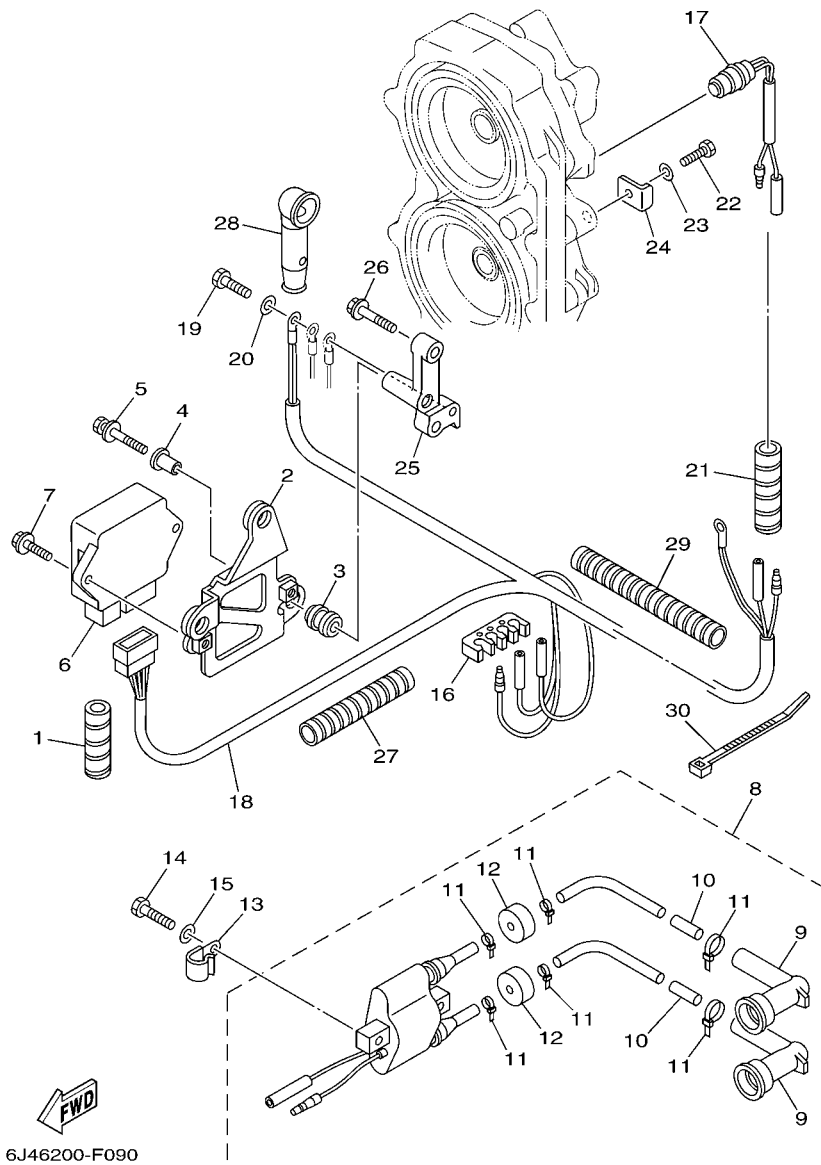

FWD
6J46200-F090

REF. NO.	PART NO. CODIGO Nº	DESCRIPTION DESCRIPCION	E40M	40MH	E40W	40WH	40W	REMARKS OBSERVACIONES
28	61A-82119-00	COVER, LEAD WIRE CUBIERTA DE CABLE CONDUCTOR	1	1				
29	65L-83557-00	TUBE ENCHUFE DE ACEITE	1	1	1	1	1	
30	90465-11M10	CLAMP BRIDA	1	1	1	1	1	

FIG. 10 ELECTRICAL 2

EQUIPO ELECTRICO 2

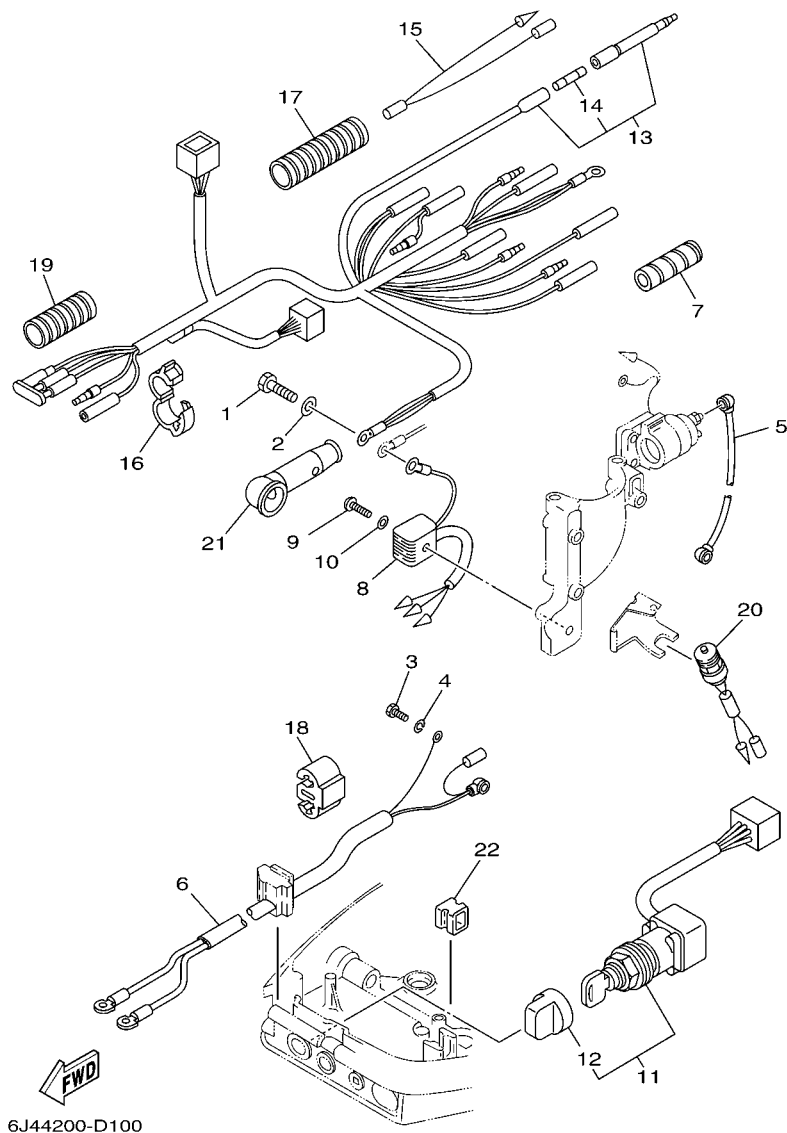

REF. NO.	PART NO. CODIGO Nº	DESCRIPTION DESCRIPCION	E40M	40MH	E40W	40WH	40W	REMARKS OBSERVACIONES
1	97095-06016	BOLT PERNO				1	1	
2	92995-06600	WASHER ARANDELA				1	1	
3	97095-08016	BOLT PERNO				1	1	
4	92995-08100	WASHER ARANDELA				1	1	
5	6F5-82117-00	WIRE, LEAD CABLE CONDUCTOR				1	1	
6	6F5-82105-00	WIRE HARNESS ARNES DE CABLES				1	1	
7	90446-10M02	HOSE TUBO RESEIRADERO				2	2	
8	6F5-81970-61	RECTIFIER ASSY RECTIFICADOR COMPLETO				1	1	
9	97880-05025	SCREW, PAN HEAD TORNILLO DE CABEZA CON PLANA				1	1	
10	92990-05600	WASHER, PLATE ARANDELA PLANA				1	1	
11	6F5-82510-10	MAIN SWITCH ASSY CONJUNTO DE LLAVE IGNICION				1	1	
12	676-82577-00	.CAP, KEY .TAPA				1	1	
13	6F5-82590-30	WIRE HARNESS ASSY CONJUNTO DE CABLES				1	1	
14	663-82151-00	.FUSE (12V-20A) .FUSIBLE (12V-20A)				1	1	
15	6F6-82509-00	WIRE, SUB LEAD CABLE SUBCONDUCTOR				1	1	
16	90464-16003	CLAMP BRIDA				1	1	
17	6G1-83557-00	TUBE ENCHUFE DE ACEITE				1	1	
18	90464-06006	CLAMP BRIDA				1	1	
19	6G5-83557-00	TUBE ENCHUFE DE ACEITE				1	1	
20	6F5-82540-00	NEUTRAL SWITCH ASSY INTERRUPTOR NEUTRAL COMPL				1	1	
21	61A-82119-00	COVER, LEAD WIRE CUBIERTA DE CABLE CONDUCTOR				1	1	
22	90480-17M08	GROMMET TAPON				1	1	

FIG. 11 ELECTRICAL 3

EQUIPO ELECTRICO 3

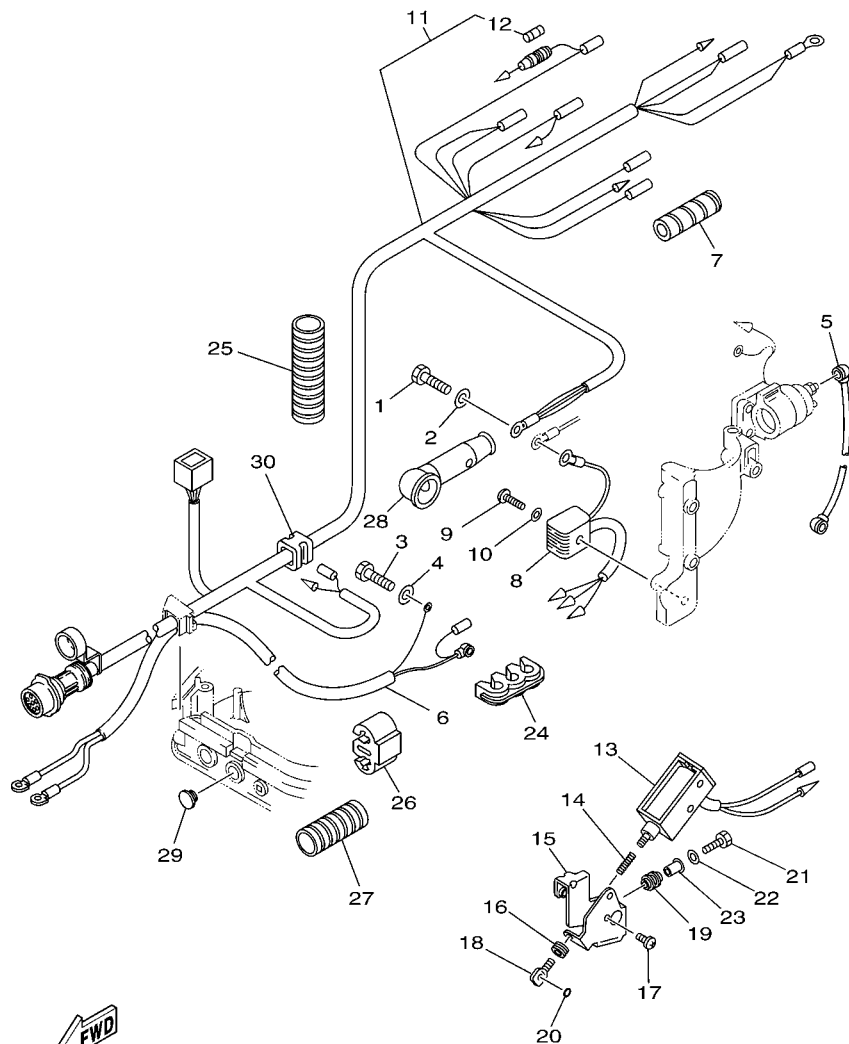

6J44200-D110

REF. NO.	PART NO. CODIGO Nº	DESCRIPTION DESCRIPCION	E40M	40MH	E40W	40WH	40W	REMARKS OBSERVACIONES
1	97095-06016	BOLT PERNO					1	
2	92995-06600	WASHER ARANDELA					1	
3	97095-08016	BOLT PERNO					1	
4	92995-08100	WASHER ARANDELA					1	
5	6F5-82117-00	WIRE, LEAD CABLE CONDUCTOR					1	
6	6F5-82105-00	WIRE HARNESS ARNES DE CABLES					1	
7	90446-10M02	HOSE TUBO RESEIRADERO					2	
8	6F5-81970-61	RECTIFIER ASSY RECTIFICADOR COMPLETO					1	
9	97880-05025	SCREW, PAN HEAD TORNILLO DE CABEZA CON PLANA					1	
10	92990-05600	WASHER, PLATE ARANDELA PLANA					1	
11	6J4-82590-10	WIRE HARNESS ASSY CONJUNTO DE CABLES					1	
12	663-82151-00	.FUSE (12V-20A) .FUSIBLE (12V-20A)					1	
13	6J4-86111-00	COIL, SOLENOID CONJUNTO BOBINA SOLENOIDE					1	
14	6J4-86116-00	WIRE, PULL ALAMBRE-JALADOR					1	
15	6J4-86112-00	STAY, SOLENOID SOPORTE SOLENOIDE					1	
16	90480-10155	GROMMET TAPON					1	
17	97880-05008	SCREW, PAN HEAD TORNILLO DE CABEZA CON PLANA					4	
18	682-86117-00	HOOK, WIRE PULL GANCHO JALADOR DE ALAMBRE					1	
19	6A0-82317-00	DAMPER, IGNITION COIL AMORTIGUADOR BOBINA ENCENDIDO					3	
20	93210-03261	O-RING ANILLO O					1	
21	97095-06025	BOLT PERNO					3	
22	92995-06600	WASHER ARANDELA					3	
23	90387-06119	COLLAR ESPACIADOR					3	
24	90468-07179	CLIP PRESILLA					1	
25	6G1-83557-00	TUBE ENCHUFE DE ACEITE					1	
26	90464-06006	CLAMP BRIDA					1	
27	6G5-83557-00	TUBE ENCHUFE DE ACEITE					1	

FIG. 11 ELECTRICAL 3

EQUIPO ELECTRICO 3

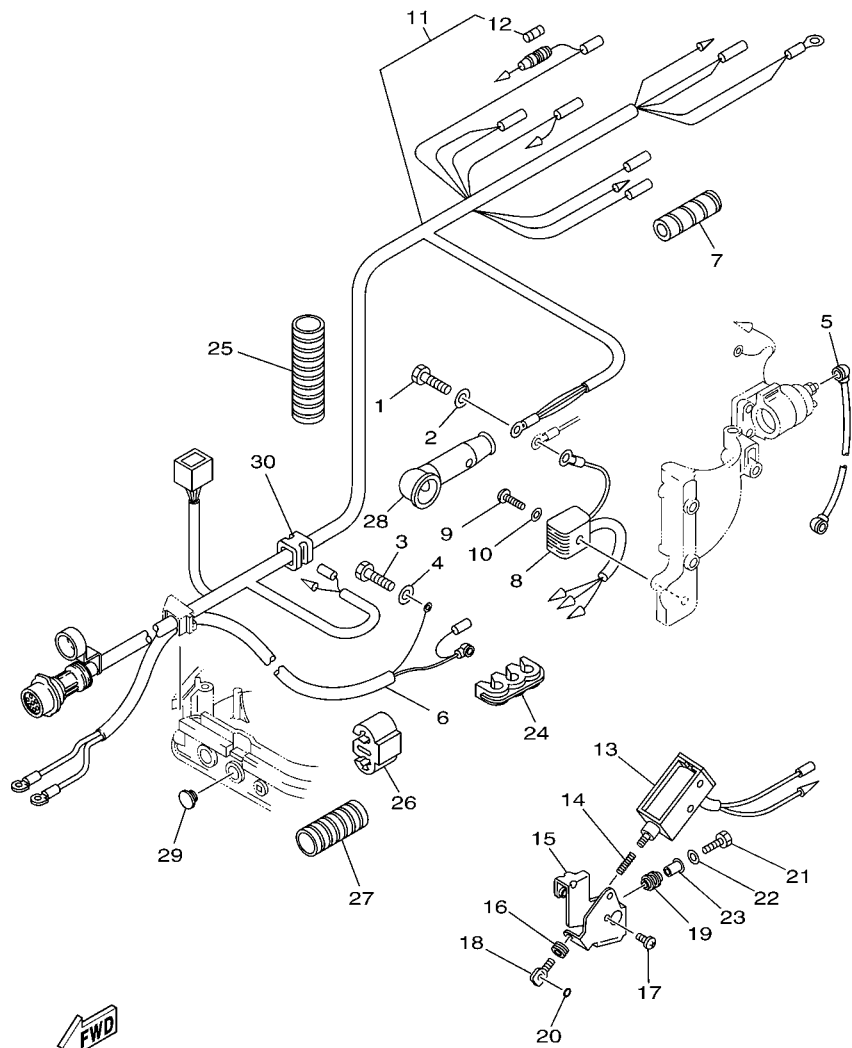

6J44200-D110

REF. NO.	PART NO. CODIGO Nº	DESCRIPTION DESCRIPCION	E40M	40MH	E40W	40WH	40W	REMARKS OBSERVACIONES
28	61A-82119-00	COVER, LEAD WIRE CUBIERTA DE CABLE CONDUCTOR					1	
29	90480-17165	GROMMET TAPON					1	
30	90480-17M08	GROMMET TAPON					1	

FIG. 12 STARTING MOTOR

MOTOR DE ARRANQUE

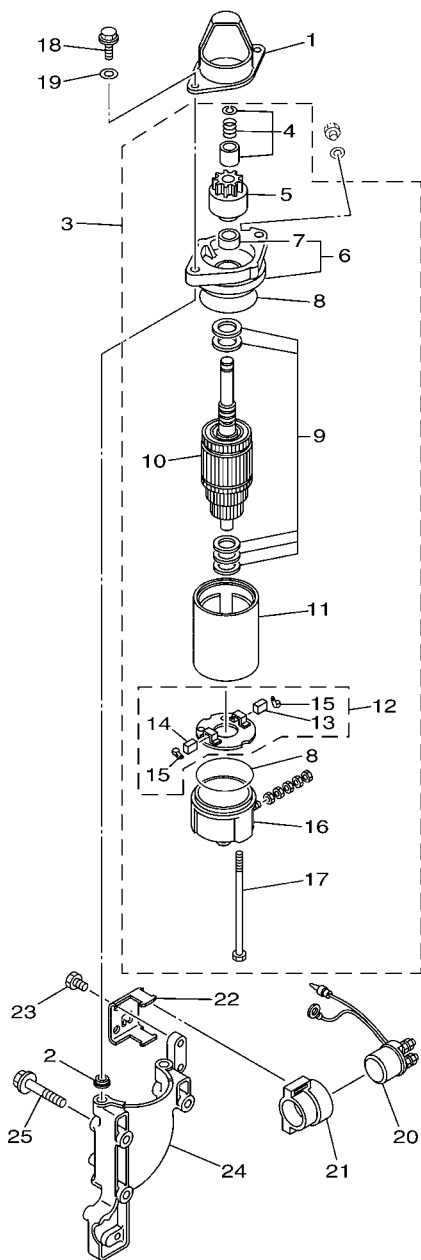

FWD
6J44200-D120

REF. NO.	PART NO. CODIGO Nº	DESCRIPTION DESCRIPCION	E40M	40MH	E40W	40WH	40W	REMARKS OBSERVACIONES
1	6F5-81842-41	COVER TAPA			1	1	1	
2	90387-08M12	COLLAR ESPACIADOR			2	2	2	
3	6J4-81800-01	STARTING MOTOR ASSY MOTOR DE ARRANQUE COMPLETO			1	1	1	
4	689-81857-11	.PINION STOPPER SET .JUEGO TAPON PINON			1	1	1	
5	689-81807-12	.GEAR ASSY, STARTING MOTOR .PINON CONJUNTO			1	1	1	
6	6F5-81830-11	.FRONT BRACKET ASSY .SOPORTE DELANTERO COMPLETO			1	1	1	
7	689-81831-00	..METAL, FRONT ..METAL, DELANTERO			1	1	1	
8	689-81847-11	.O-RING .ANILLO GOMA			2	2	2	
9	689-81809-11	.WASHER KIT .JUEGO DE ARANDELA			1	1	1	
10	689-81850-12	.ARMATURE ASSY .INDUCIDO COMPLETO			1	1	1	
11	689-81810-11	.STATOR ASSY .ESTATOR COMPLETO			1	1	1	
12	689-81840-11	.BRUSH HOLDER ASSY .SOSTEN DE ESCOBILLA COMPLETO			1	1	1	
13	689-81811-11	..BRUSH 1 ..ESCOBILLA 1			1	1	1	
14	689-81812-11	..BRUSH 2 ..ESCOBILLA 2			1	1	1	
15	689-81813-10	..SPRING, BRUSH ..RESORTE DE ESCOBILLA			2	2	2	
16	689-81820-11	.REAR BRACKET ASSY .CUBIERTA TRASERA COMPL			1	1	1	
17	689-81826-10	.BOLT .PERNO			2	2	2	
18	90105-08M50	BOLT, FLANGE TORNILLO			2	2	2	
19	92990-08600	WASHER, PLATE ARANDELA PLANA			2	2	2	
20	6G1-81941-10	STARTER RELAY ASSY RELE DE ARRANQUE			1	1	1	
21	6G1-81952-00	HOLDER, RELAY SOSTEN DE RELE			1	1	1	
22	6F5-81945-00	PLATE, SWITCH FITTING PLACA ACCESORIA DE INTERRUP.			1	1	1	
23	97095-06012	BOLT PERNO			2	2	2	
24	6J4-81820-01	REAR BRACKET ASSY CUBIERTA TRASERA COMPL			1	1	1	
25	90105-08M51	BOLT, FLANGE TORNILLO			3	3	3	

FIG. 13 BOTTOM COWLING

CUBIERTA INFERIOR

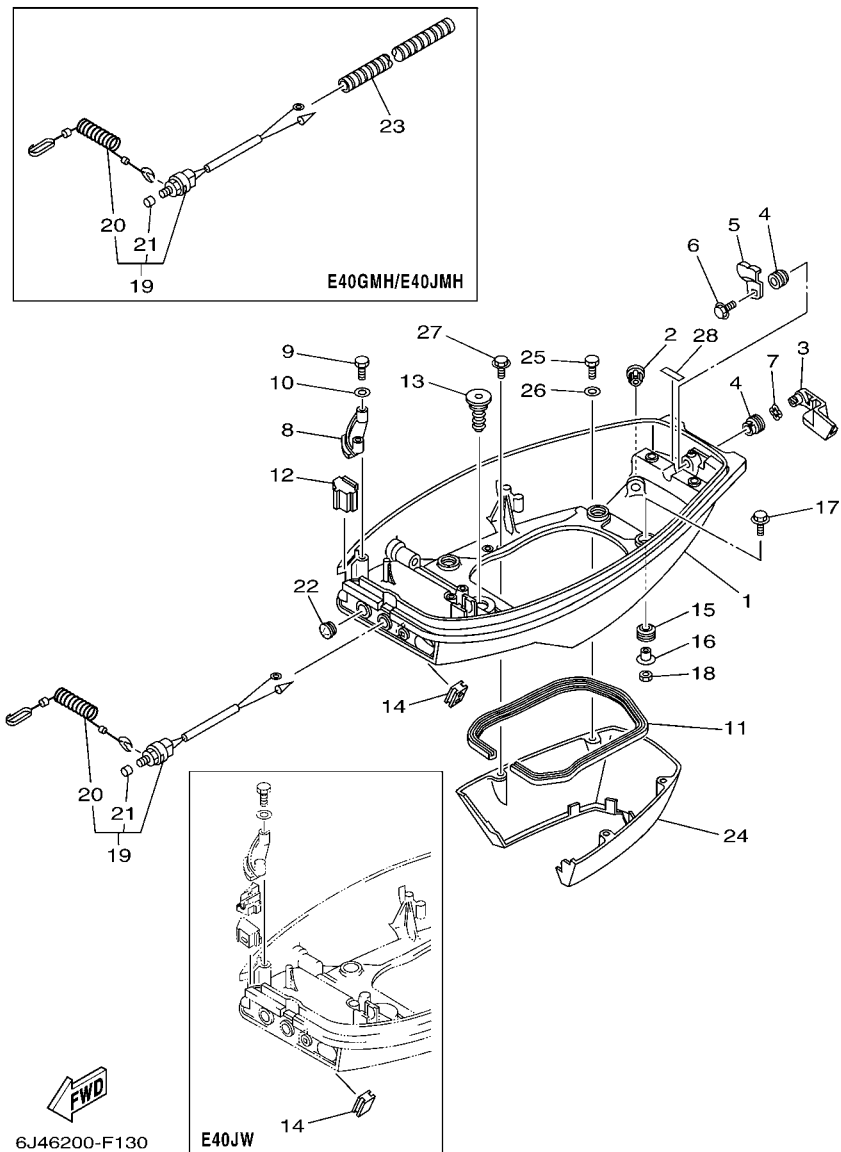

REF. NO.	PART NO. CODIGO Nº	DESCRIPTION DESCRIPCION	E40M	40MH	E40W	40WH	40W	REMARKS OBSERVACIONES
1	6F6-42711-03-4D	COWLING, BOTTOM 1 CUBIERTA INFERIOR 1	1	1	1	1	1	
2	6E5-44391-00	NIPPLE, HOSE NIPLE MANGUERA	1	1	1	1	1	
3	6F5-42815-01-4D	LEVER, CLAMP PALANCA ABRAZADERA	1	1	1	1	1	
4	90386-12M37	BUSH BUJE	2	2	2	2	2	
5	6F5-42816-00	LEVER, CLAMP PALANCA ABRAZADERA	1	1	1	1	1	
6	90119-06M73	BOLT, WITH WASHER TORNILLO CON ARANDELA	1	1	1	1	1	
7	90206-12052	WASHER, WAVE ARANDELA ONDULADA	1	1	1	1	1	
8	6F5-42738-01-94	PLATE, FITTING PLACA DE AJUSTE	1	1	1	1	1	
9	97013-06025	BOLT PERNO	2	2	2	2	2	
10	92903-06600	WASHER, PLATE RONDANA SENCILLA	2	2	2	2	2	
11	6F5-42716-00	RUBBER, SEAL 1 SELLO DE GOMA 1	1	1	1	1	1	
12	6F5-42724-00	GROMMET TAPON	1	1				
	6F5-42724-40	GROMMET TAPON			1	1		
13	6F5-42727-00	GROMMET TAPON	1	1	1	1	1	
14	676-26326-00	GROMMET TAPON PROTECTOR	1	1	1	1		
	676-42724-40	GROMMET TAPON					1	
15	90480-09M21	GROMMET TAPON	4	4	4	4	4	
16	90387-06035	COLLAR ESPACIADOR	4	4	4	4	4	
17	90119-06M61	BOLT, WITH WASHER TORNILLO CON ARANDELA	4	4	4	4	4	
18	95380-06600	NUT, HEXAGON TUERCA	4	4	4	4	4	
19	6E9-82575-02	ENGINE STOP SWITCH ASSY INTERRUPTOR DE PARADA COMPL	1	1	1	1	1	
20	682-82556-00	.LANYARD, STOP SWITCH .RETENER	1	1	1	1	1	
21	689-8257Y-00	.CAP .CASQUILLO	1	1	1	1	1	
22	676-42726-00	GROMMET TAPON	1	1			1	
23	90447-13011	HOSE, WITH SPRING MANGUERA CON RESORTE	1	1				
24	6F5-42741-11	APRON MANDIL	1	1	1	1	1	
25	97095-06025	BOLT PERNO	2	2	2	2	2	

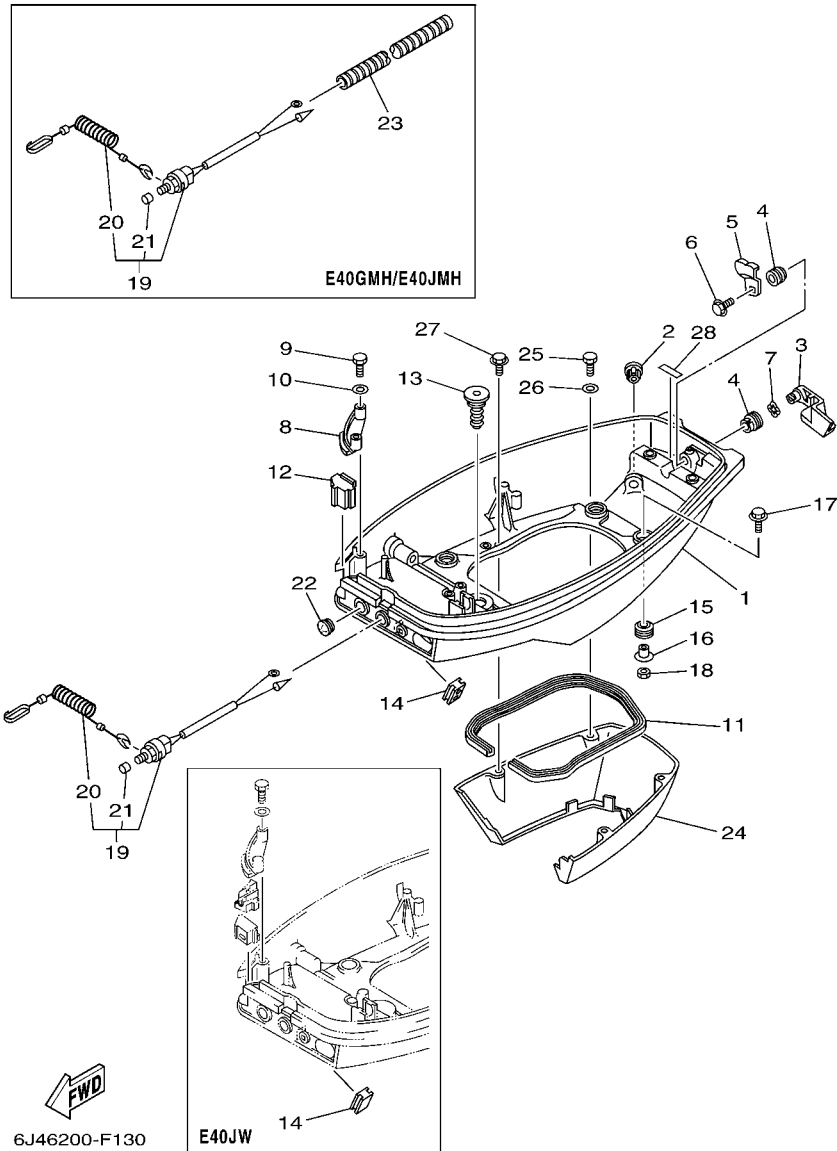
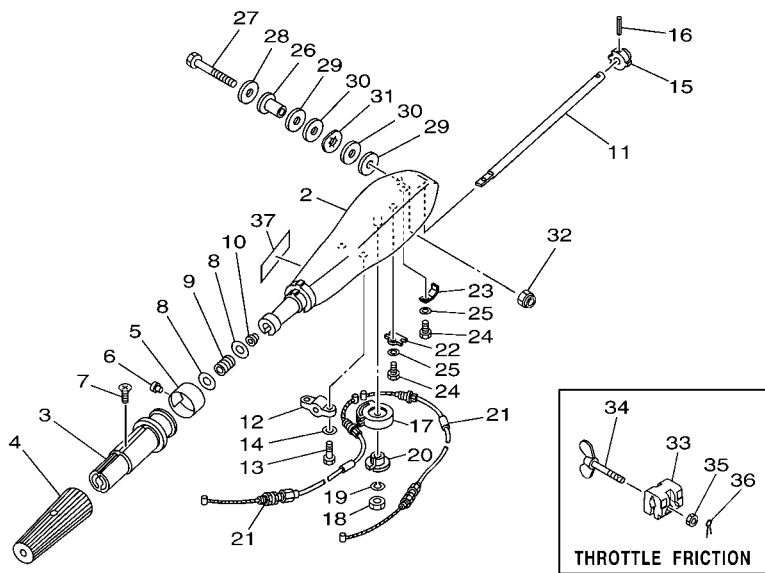

FIG. 13 BOTTOM COWLING

CUBIERTA INFERIOR

REF. NO.	PART NO. CODIGO Nº	DESCRIPTION DESCRIPCION	E40M	40MH	E40W	40WH	40W	REMARKS OBSERVACIONES
26	92995-06600	WASHER ARANDELA	2	2	2	2	2	
27	90119-06M11	BOLT, WITH WASHER TORNILLO CON ARANDELA	2	2	2	2	2	
28	664-42791-00	MARK 1 MARCA 1	1	1	1	1	1	EXCEPT E40J-CHN EXCEPT E40J-CHN E40J-FOR CHN E40J-FOR CHN
	664-42791-10	MARK 1 MARCA 1			1	1	1	

1
**HANDLE STEERING
 ASSY**
 (Fig. 14, Ref. No. 2 to 32)



6J44200-D140

FIG. 14 STEERING

DIRECCION

REF. NO.	PART NO. CODIGO Nº	DESCRIPTION DESCRIPCION	E40M	40MH	E40W	40WH	40W	REMARKS OBSERVACIONES
1	6F6-W0084-01-4D	HANDLE STEERING ASSY CONJUNTO DE MANIJA	1	1	1	1		
2	676-42111-03-4D	HANDLE, STEERING MANIJA DE DIRECCION	1	1	1	1		
3	664-42119-00	GRIP, STEERING HANDLE MANGO, MANIJA DE DIRRECCION	1	1	1	1		
4	6F6-42177-A0	RUBBER, HANDLE HULE DE MANIJA	1	1	1	1		
5	6F6-42137-10	INDICATOR, THROTTLE INDICADOR ACELERADOR	1	1	1	1		
6	90269-02M09	RIVET REMACHE	1	1	1	1		
7	90149-05M13	SCREW TORNILLO DE REGLAJE	1	1	1	1		
8	90201-10M02	WASHER, PLATE ARANDELA PLANA	2	2	2	2		
9	90501-23215	SPRING, COMPRESSION RESORTE DE COMPRESION	1	1	1	1		
10	90386-08032	BUSH BUJE	1	1	1	1		
11	676-42115-00	SHAFT, STEERING HANDLE EJE MANIJA DE DIRECCION	1	1	1	1		
12	676-42159-00	STAY SOPORTE	1	1	1	1		
13	97095-06020	BOLT PERNO	2	2	2	2		
14	92995-06600	WASHER ARANDELA	2	2	2	2		
15	650-42152-00-94	GEAR ENGRANE	1	1	1	1		
16	91690-30025	PIN, SPRING PASADOR DE RESORTE	1	1	1	1		
17	676-42151-00-94	PINION PINON	1	1	1	1		
18	95380-06600	NUT, HEXAGON TUERCA	1	1	1	1		
19	92990-06100	WASHER, SPRING ARANDELA PLANA	1	1	1	1		
20	90386-08M00	BUSH BUJE	1	1	1	1		
21	6F5-26311-00	CABLE, THROTTLE 1 CABLE DE ACELERADOR 1	2	2	2	2		
22	676-26391-00	CLIP, CABLE PRESILLA DE CABLE	1	1	1	1		
23	676-26392-00	CLIP, CABLE 2 PRESILLA DE CABLE 2	1	1	1	1		
24	97095-05010	BOLT PERNO	2	2	2	2		
25	92995-05600	WASHER ARANDELA	2	2	2	2		
26	90386-12089	BUSH BUJE	1	1	1	1		
27	90101-12M37	BOLT TORNILLO	1	1	1	1		

1
**HANDLE STEERING
 ASSY**
 (Fig. 14, Ref. No. 2 to 32)

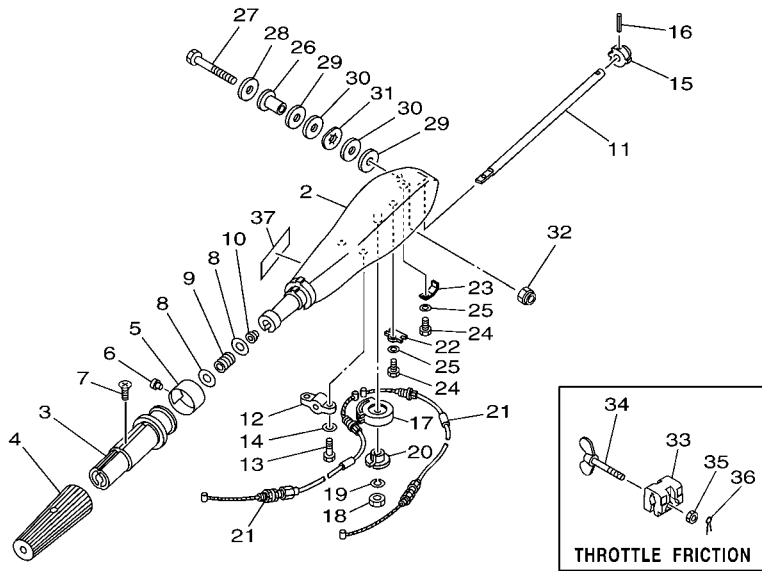

6J44200-D140

FIG. 14 STEERING

DIRECCION

REF. NO.	PART NO. CODIGO N°	DESCRIPTION DESCRIPCION	E40M	40MH	E40W	40WH	40W	REMARKS OBSERVACIONES
28	92990-12200	WASHER, PLAIN ARANDELA PLANA	1	1	1	1		
29	90202-12092	WASHER, PLATE ARANDELA DE PLANA	2	2	2	2		
30	90201-12537	WASHER, PLATE ARANDELA PLANA	2	2	2	2		
31	90206-12054	WASHER, WAVE ARANDELA ONDULADA	1	1	1	1		
32	90185-12058	NUT, SELF-LOCKING TUERCA AUTOBLOCANTE	1	1	1	1		
33	6F5-42126-00	FRICTION, STEERING HANDLE GRIP FRICCION DE MANGO DIRECCION	1	1	1	1		
34	6F5-42125-00	BOLT, FRICTION ADJUSTING TORNILLO FRICCION ADJUSTA	1	1	1	1		
35	95380-06600	NUT, HEXAGON TUERCA	1	1	1	1		
36	91490-16010	PIN, COTTER CHAVETA	1	1	1	1		
37	6E0-83627-41	LABEL, CAUTION 7 ETIQUETA DE PRECAUCION 7	1	1	1	1		

FIG. 15 CONTROL 1

CONTROL 1

REF. NO.	PART NO. CODIGO Nº	DESCRIPTION DESCRIPCION	E40M	40MH	E40W	40WH	40W	REMARKS OBSERVACIONES
1	6F5-14497-00	STAY, THROTTLE WIRE SOPORTE VALVULA DE OBTURACION	1	1	1	1	1	
2	6F5-41638-00	PULLEY POLEA	1	1	1	1	1	
3	6F5-41283-00	LEVER, FREE ACCEL. PALANCA	1	1	1	1	1	
4	90387-06M29	COLLAR ESPACIADOR	1	1	1	1	1	
5	97095-06030	BOLT PERNO	1	1	1	1	1	
6	92995-06600	WASHER ARANDELA	1	1	1	1	1	
7	97095-06016	BOLT PERNO	1	1	1	1	1	
8	92995-06600	WASHER ARANDELA	1	1	1	1	1	
9	6F5-41211-00	LINK, ACCEL. ESLABON, ACELERADOR	1	1	1	1	1	
10	6E9-41237-00	JOINT, LINK CONECTOR	2	2	2	2	2	
11	6F5-44111-00	HANDLE, GEAR SHIFT MANIJA DE CAMBIO DE MARCHAS	1	1	1	1	1	
12	6F5-44125-00	LEVER, SHIFT ROD PALANCA VARILLA CAMBIOS	1	1	1	1	1	
13	91690-25016	PIN, SPRING PASADOR DE RESORTE	1	1	1	1	1	
14	6F5-41662-00	BRACKET SOPORTE	1	1	1	1	1	
15	97013-06025	BOLT PERNO	2	2	2	2	2	
16	92903-06600	WASHER, PLATE RONDANA SENCILLA	2	2	2	2	2	
17	6F5-44121-00	LEVER, SHIFT ROD PALANCA VARILLA CAMBIOS	1	1	1	1	1	
18	90240-05M09	PIN, CLEVIS PASADOR CON HOYO	1	1	1	1	1	
19	91490-16010	PIN, COTTER CHAVETA	1	1	1	1	1	
20	97780-40520	SCREW, TAPPING TORNILLO DE CABEZA DE CONO ACH	2	2	2	2	2	
21	6F5-44173-00	LEVER, SHIFT CONTROL PALANCA CONTROL CAMBIOS	1	1	1	1	1	
22	6F5-42715-00	BUSHING BUJE	1	1	1	1	1	
23	6F5-44167-00	PLUNGER, SHIFT CAM EMBOLO DE CAMBIO	1	1	1	1	1	
24	90501-12M36	SPRING, COMPRESSION RESORTE DE COMPRESION	1	1	1	1	1	
25	90501-07M33	SPRING, COMPRESSION RESORTE DE COMPRESION	1	1	1	1	1	
26	676-44143-00	ROD, SHIFT VARILLA DE CAMBIO	1	1	1	1	1	
27	648-44146-00	CONNECTOR, SHIFT ROD CONECTOR VARILLA DE CAMBIO	1	1	1	1	1	

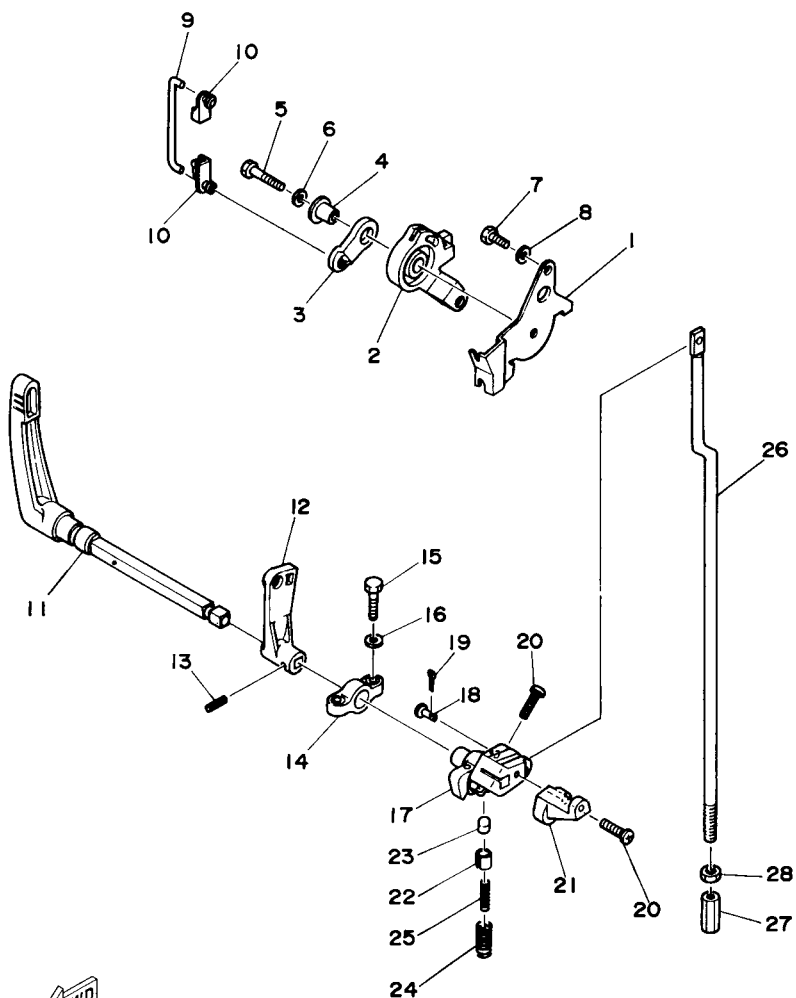

6H90010-4150

FIG. 17 BRACKET 1

SOPORTE 1

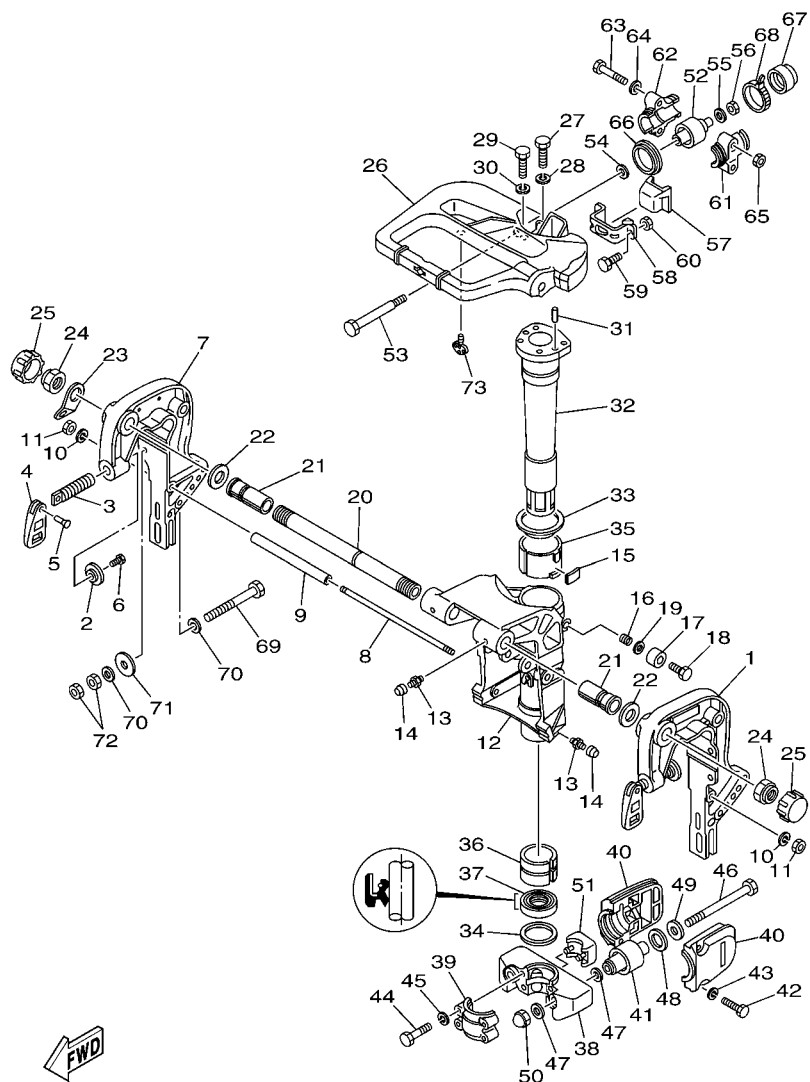

6J44200-D170

REF. NO.	PART NO. CODIGO Nº	DESCRIPTION DESCRIPCION	E40M	40MH	E40W	40WH	40W	REMARKS OBSERVACIONES
1	676-43111-04-4D	BRACKET, CLAMP 1 SOPORTE DE LA ABRAZADERA 1	1	1	1	1	1	
2	6F5-43114-00	PAD, TRANSOM CLAMP ARANDELA DE ABRAZADERA	2	2	2	2	2	
3	6F5-43116-00	SCREW, TRANSOM CLAMP TORNILLO DE ABRAZADERA	2	2	2	2	2	
4	663-43118-01-4D	HANDLE, TRANSOM CLAMP MANIJA DE LA ABRAZADERA DEL ES	2	2	2	2	2	
5	90243-04007	PIN PASADOR	2	2	2	2	2	
6	90109-06M12	BOLT PERNO	2	2	2	2	2	
7	676-43112-04-4D	BRACKET, CLAMP 2 SOPORTE DE LA ABRAZADERA 2	1	1	1	1	1	
8	90116-08M00	BOLT, STUD ESPARRAGO	1	1	1	1	1	
9	90387-08M02	COLLAR ESPACIADOR	1	1	1	1	1	
10	92990-08100	WASHER, SPRING ARANDELA PLANA	2	2	2	2	2	
11	95380-08600	NUT TUERCA	2	2	2	2	2	
12	676-43311-10-4D	BRACKET, SWIVEL 1 SOPORTE GIRATORIO 1	1	1	1	1	1	
13	93700-06M03	NIPPLE, GREASE BOQUILLA DE ENGRASAR	4	4	4	4	4	
14	663-45119-00	CAP, GREASE NIPPLE TAPA DE GRASERA	4	4	4	4	4	AP AP
15	648-42528-00	PLATE, FRICTION PIEZA DE FRICCION	1	1	1	1	1	
16	90501-18M00	SPRING, COMPRESSION RESORTE DE COMPRESION	1	1	1	1	1	
17	676-43373-00	SEAL, DAMPER SELLO DE GOMA	1	1	1	1	1	
18	97075-08025	BOLT PERNO	1	1	1	1	1	
19	92995-08600	WASHER ARANDELA	1	1	1	1	1	
20	6J8-43131-01	BOLT, CLAMP BRACKET TORNILLO DE ABRAZADERA DEL SOP	1	1	1	1	1	
21	90386-22M15	BUSH BUJE	2	2	2	2	2	
22	90201-22M03	WASHER, PLATE ARANDELA PLANA	2	2	2	2	2	
23	6J8-43113-01	PLATE, CLAMP BRACKET PLACA ABRAZADERA SOPORTE	1	1	1	1	1	
24	90185-22043	NUT, SELF-LOCKING TUERCA AUTOBLOCANTE	2	2	2	2	2	
25	6G5-43145-01	CAP, CLAMP BRACKET TAPA	2	2	2	2	2	
26	676-42511-03-4D	BRACKET, STEERING SOPORTE DE DIRECCION	1	1	1	1	1	
27	97075-08030	BOLT PERNO	2	2	2	2	2	

FIG. 17 BRACKET 1

SOPORTE 1

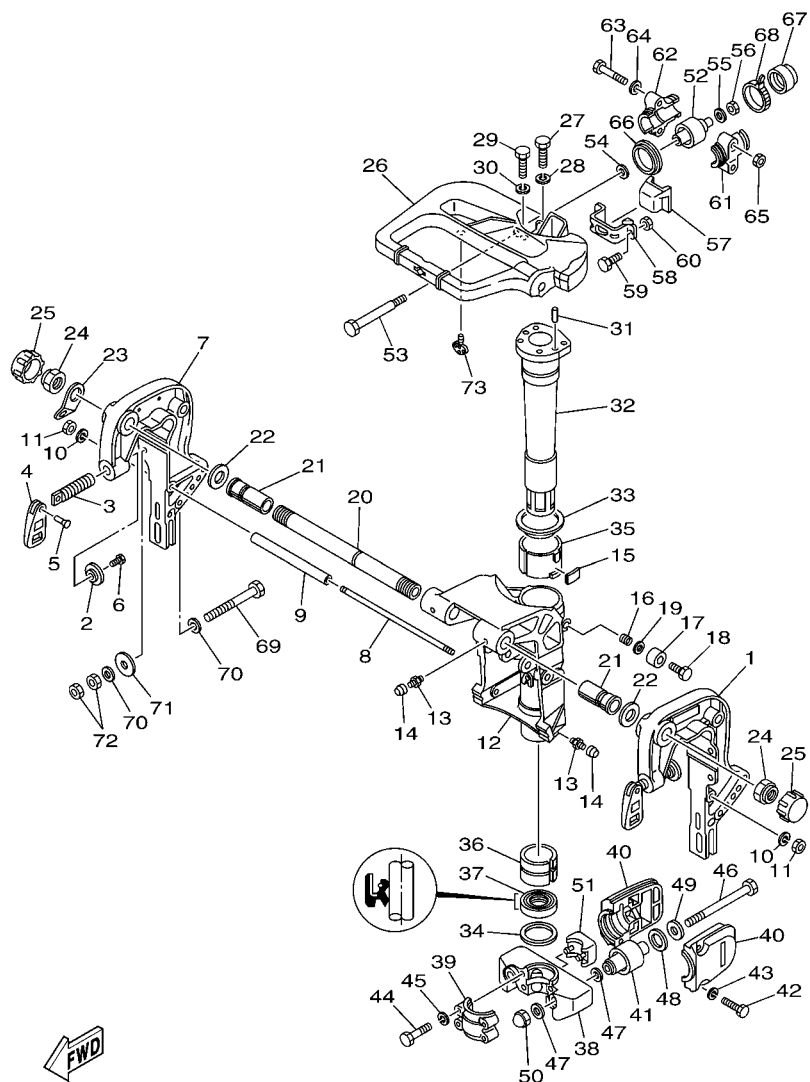

6J44200-D170

REF. NO.	PART NO. CODIGO Nº	DESCRIPTION DESCRIPCION	E40M	40MH	E40W	40WH	40W	REMARKS OBSERVACIONES
28	92995-08100	WASHER ARANDELA	2	2	2	2	2	
29	97075-08035	BOLT PERNO	2	2	2	2	2	
30	92995-08100	WASHER ARANDELA	2	2	2	2	2	
31	93608-12063	PIN, DOWEL PASADOR DE CLAVIJA	2	2	2	2	2	
32	676-42521-00-94	SHAFT, STEERING PIVOT EJE PIVOTE DE DIRECCION	1	1	1	1	1	
33	90209-52M00	WASHER ARANDELA DE SEPARACION	1	1	1	1	1	
34	90201-44M01	WASHER, PLATE ARANDELA PLANA	1	1	1	1	1	
35	90386-52M02	BUSH BUJE	1	1	1	1	1	
36	90386-44M03	BUSH BUJE	1	1	1	1	1	
37	93109-44M00	OIL SEAL SELLO ACEITE	1	1	1	1	1	
38	676-44551-01-4D	HOUSING, LOWER MOUNT RUBBER CAJA AMORTIGUADOR INFERIOR HU	1	1	1	1	1	
39	676-44552-01-4D	HOUSING, LOWER MOUNT RUBBER CAJA AMORTIGUADOR INFERIOR HU	1	1	1	1	1	
40	676-44553-01-4D	COVER, LOWER MOUNT CUBIERTA, AMORTIGUADOR INFERIOR	2	2	2	2	2	
41	679-44555-00-94	MOUNT DAMPER, LOWER SIDE AMORTIGUADOR DE HULE LADO INFE	2	2	2	2	2	
42	97075-08030	BOLT PERNO	4	4	4	4	4	
43	92995-08100	WASHER ARANDELA	4	4	4	4	4	
44	97095-08045	BOLT PERNO	4	4	4	4	4	
45	92995-08100	WASHER ARANDELA	4	4	4	4	4	
46	90101-12M01	BOLT TORNILLO	2	2	2	2	2	
47	90201-12M16	WASHER, PLATE ARANDELA PLANA	4	4	4	4	4	
48	90202-21100	WASHER, PLATE ARANDELA DE PLANA	2	2	2	2	2	
49	90201-13M11	WASHER, PLATE ARANDELA PLANA	2	2	2	2	2	
50	95380-12800	NUT, CROWN TUERCA	2	2	2	2	2	
51	676-44575-00	DAMPER, LOWER MOUNT RUBBER AMORTIGUADOR INFERIOR	1	1	1	1	1	
52	679-44514-00-94	MOUNT DAMPER, UPPER SIDE AMORTIGUADOR LADO SUPERIOR	2	2	2	2	2	
53	90101-08M02	BOLT TORNILLO	2	2	2	2	2	
54	90201-08M08	WASHER, PLATE ARANDELA PLANA	2	2	2	2	2	

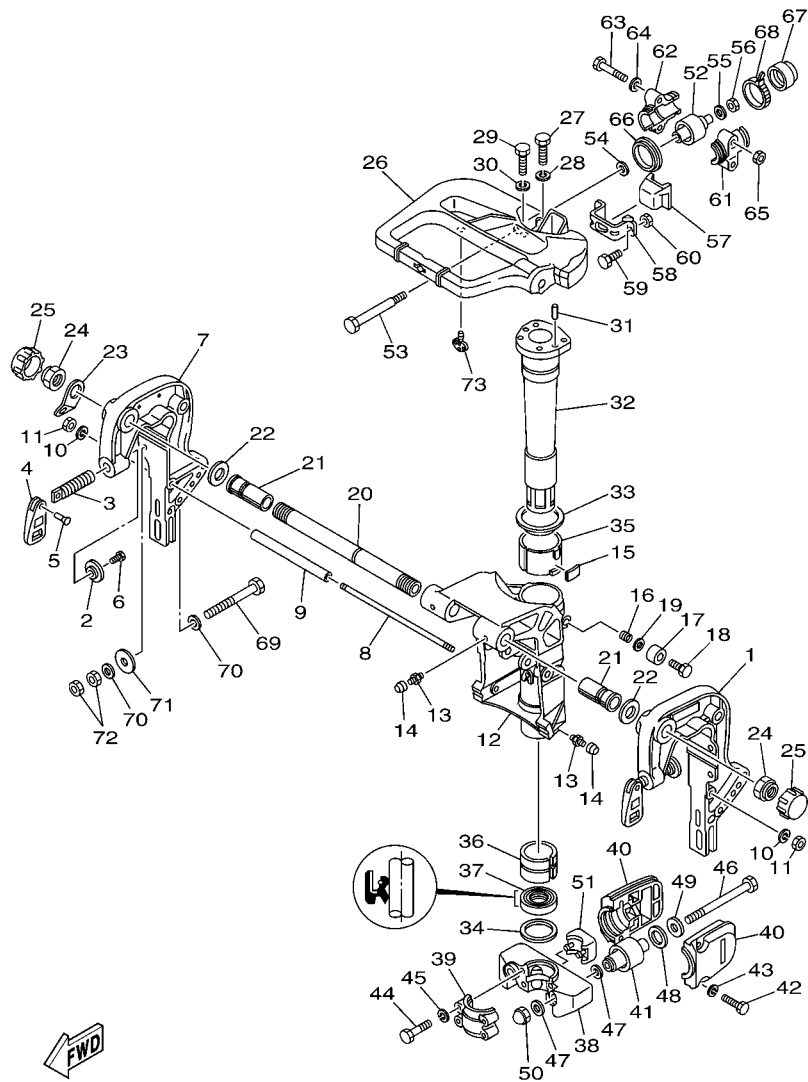

6J44200-D170

FIG. 17 BRACKET 1

SOPORTE 1

REF. NO.	PART NO. CODIGO Nº	DESCRIPTION DESCRIPCION	E40M	40MH	E40W	40WH	40W	REMARKS OBSERVACIONES
55	90201-09M00	WASHER, PLATE ARANDELA PLANA	2	2	2	2	2	
56	90185-08057	NUT, SELF-LOCKING TUERCA AUTOBLOCANTE	2	2	2	2	2	
57	676-44533-00	DAMPER, UPPER MOUNT RUBBER AMORTIGUADOR SUPERIOR	1	1	1	1	1	
58	676-44518-00	BRACKET COMP. SOPORTE	1	1	1	1	1	
59	97095-06025	BOLT PERNO	2	2	2	2	2	
60	95380-06600	NUT, HEXAGON TUERCA	2	2	2	2	2	
61	676-44511-00-94	COVER, UPPER MOUNT CUBIERTA AMORTIGUADOR SUPERIOR	2	2	2	2	2	
62	676-44512-00-94	COVER, UPPER MOUNT CUBIERTA AMORTIGUADOR SUPERIOR	2	2	2	2	2	
63	97095-08050	BOLT PERNO	4	4	4	4	4	
64	92995-08600	WASHER ARANDELA	4	4	4	4	4	
65	95380-08600	NUT TUERCA	4	4	4	4	4	
66	676-44521-00	SEAL SELLO DE GOMA	2	2	2	2	2	
67	676-44522-01	SEAL SELLO DE GOMA	2	2	2	2	2	
68	90465-11M52	CLAMP BRIDA	2	2	2	2	2	
69	90101-10M58	BOLT TORNILLO	4	4	4	4	4	
70	92995-10600	WASHER ARANDELA	8	8	8	8	8	
71	90201-12426	WASHER, PLATE ARANDELA PLANA	4	4	4	4	4	
72	95380-10600	NUT TUERCA	8	8	8	8	8	
73	676-42591-00	HOLDER, SHEAR PIN SUJETADOR, PASADOR DE HELICE	1	1				E40G E40G

FIG. 18 BRACKET 2

SOPORTE 2

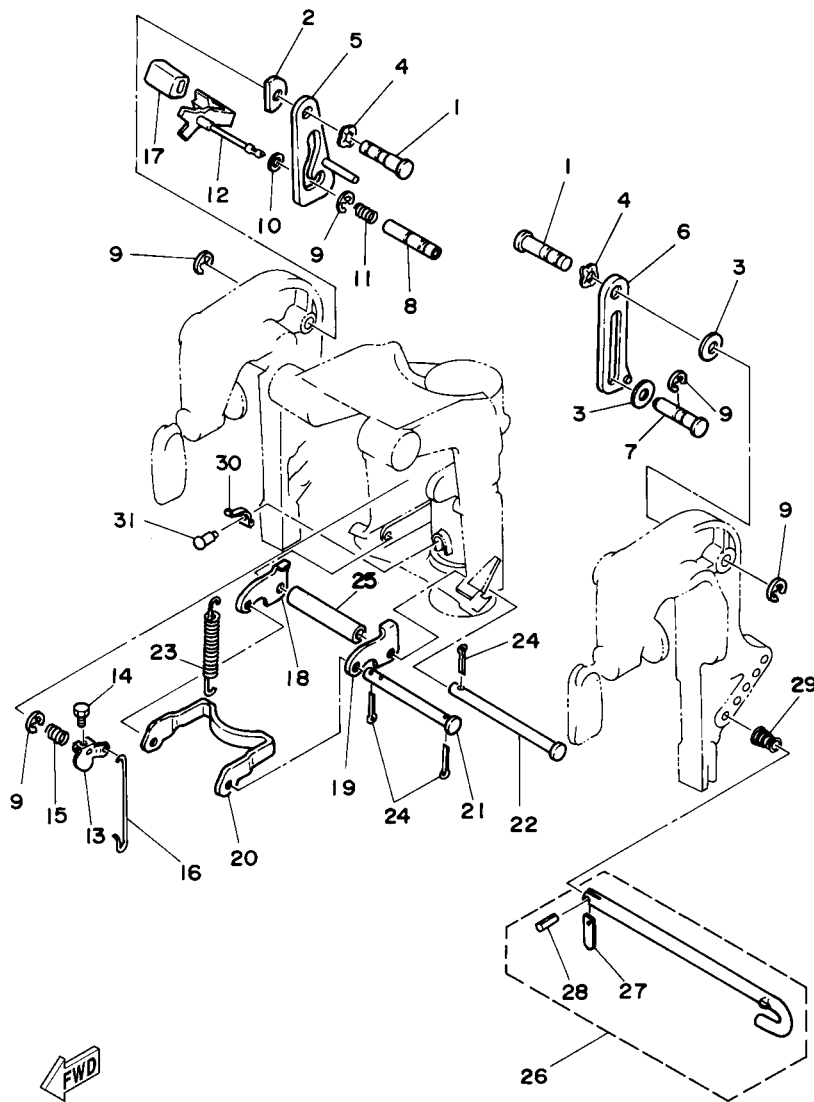

6J40200-4180

REF. NO.	PART NO. CODIGO Nº	DESCRIPTION DESCRIPCION	E40M	40MH	E40W	40WH	40W	REMARKS OBSERVACIONES
1	90249-12M27	PIN PASADOR	2	2	2	2	2	
2	676-43132-00	WASHER, FRICTION ARANDELA DE FRICCION	1	1	1	1	1	
3	90202-12M01	WASHER, PLATE ARANDELA DE PLANA	2	2	2	2	2	
4	90206-12M00	WASHER, WAVE ARANDELA ONDULADA	2	2	2	2	2	
5	6F5-43627-80	STOPPER RETEN	1	1	1	1	1	
6	6F5-43628-80	STOPPER RETEN	1	1	1	1	1	
7	90249-12M13	PIN PASADOR	1	1	1	1	1	
8	676-43191-00	SHAFT, STOPPER EJE DE TOPE	1	1	1	1	1	
9	93430-10M00	CIRCLIP SEGURO	5	5	5	5	5	
10	90202-06M00	WASHER, PLATE ARANDELA DE PLANA	1	1	1	1	1	
11	90501-14M05	SPRING, COMPRESSION RESORTE DE COMPRESION	1	1	1	1	1	
12	6F5-43630-80	TILT LEVER ASSY PLANCA DE INCLINACION COMPL	1	1	1	1	1	
13	676-43631-00	LEVER, TILT PALANCA DE INCLINACION	1	1	1	1	1	
14	97095-05010	BOLT PERNO	1	1	1	1	1	
15	90508-14M00	SPRING, TORSION RESORTE DE TORSION	1	1	1	1	1	
16	676-43616-00	ROD, TILT LOCK VARILLA SEGURO DE INCLINACION	1	1	1	1	1	
17	663-43318-00	COVER CUBIERTA	1	1	1	1	1	
18	676-43614-00	PLATE, TILT LOCK PLACA DE SEGURO DE INCLINACION	1	1	1	1	1	
19	676-43615-00	PLATE, TILT LOCK PLACA DE SEGURO DE INCLINACION	1	1	1	1	1	
20	676-43613-00	ARM, TILT LOCK BRAZO DE SEGURO DE INCLINACION	1	1	1	1	1	
21	90249-07M01	PIN PASADOR	1	1	1	1	1	
22	90249-07M02	PIN PASADOR	1	1	1	1	1	
23	90506-30M00	SPRING, TENSION RESORTE DE TENSION	2	2	2	2	2	
24	91490-20012	PIN, COTTER CHAVETA	4	4	4	4	4	
25	90387-07M04	COLLAR ESPACIADOR	1	1	1	1	1	
26	676-43160-02	TILT ROD ASSY VARILLA DE BASCULACION COMPL.	1	1	1	1	1	
27	676-43165-00	PLATE, TILT LOCK PLACA DE TOPE, VARILLA SEGURO	1	1	1	1	1	

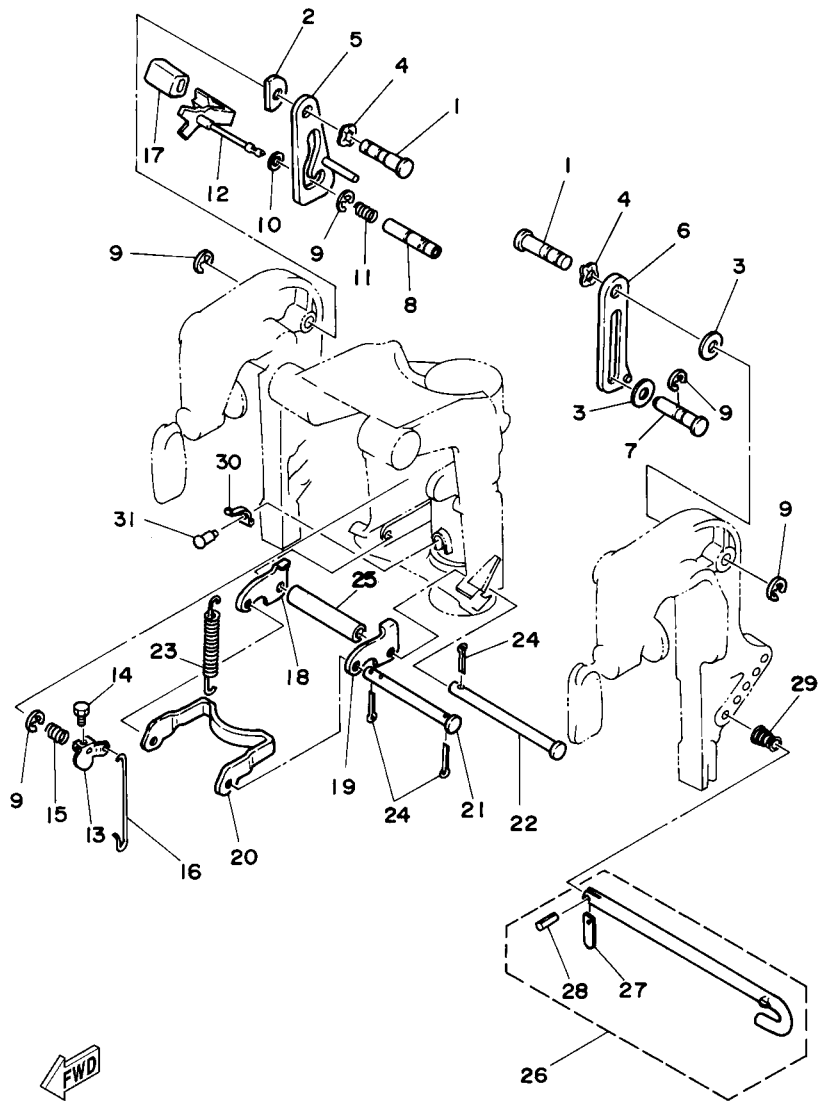

6J40200-4180

FIG. 18 BRACKET 2

SOPORTE 2

REF. NO.	PART NO. CODIGO Nº	DESCRIPTION DESCRIPCION	E40M	40MH	E40W	40WH	40W	REMARKS OBSERVACIONES
28	91690-30010	.PIN, SPRING .PASADOR DE RESORTE	1	1	1	1	1	
29	90502-10M04	SPRING, CONICAL RESORTE CONICO	1	1	1	1	1	
30	676-43643-00	SPRING RESORTE	1	1	1	1	1	
31	90269-04M00	RIVET REMACHE	1	1	1	1	1	

FIG. 19 UPPER CASING 1

FUNDA SUPERIOR 1

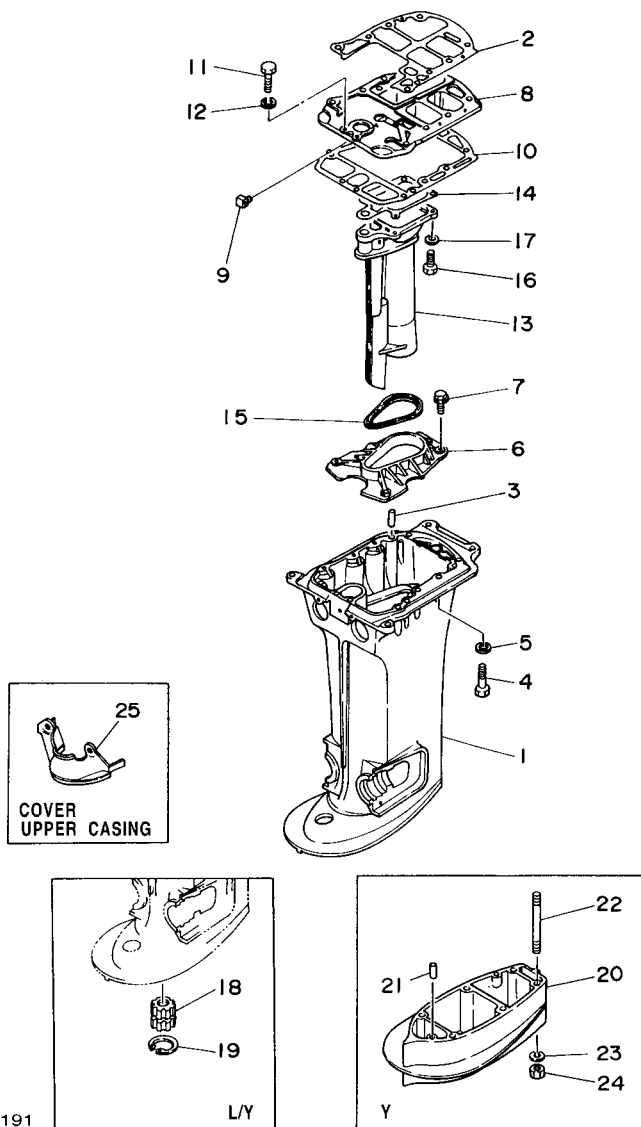

REF. NO.	PART NO. CODIGO Nº	DESCRIPTION DESCRIPCION	E40M	40MH	E40W	40WH	40W	REMARKS OBSERVACIONES
1	676-45111-03-4D	CASING, UPPER CAJA SUPERIOR		1				S(16.6") S(16.6")
	6H9-45111-11-4D	CASING, UPPER CAJA SUPERIOR		1	1	1		L(21.6"),Y(23.5") L(21.6"),Y(23.5")
2	6F5-45113-A0	GASKET, UPPER CASING EMPAQUE		1		1		
3	93606-25M00	PIN, DOWEL PASADOR DE CLAVIJA		2		2		
4	97095-08040	BOLT PERNO		8		8		
5	92995-08100	WASHER ARANDELA		8		8		
6	6F5-41116-00-5B	PROTECTOR PROTECTOR		1		1		
7	90105-06M01	BOLT, FLANGE TORNILLO		4		4		
8	6F5-41137-02-94	GUIDE, EXHAUST GUIA DE ESCAPE		1		1		
9	6F5-41141-00	ELBOW, WATER MIXING SELLO		1		1		
10	676-45114-A1	GASKET, UPPER CASING EMPAQUE		1		1		
11	97095-06025	BOLT PERNO		3		3		
12	92995-06100	WASHER, SPRING ARANDELA		3		3		
13	676-41131-01-5B	MANIFOLD, EXT. 1 TUBO MULTIPLE DE ESCAPE		1		1		
14	676-41133-A1	GASKET, EXHAUST MANIFOLD 1 EMPAQUE ESCAPE MULTIPLE		1		1		
15	676-45127-00	SEAL SELLO DE GOMA		1		1		
16	97095-06020	BOLT PERNO		4		4		
17	92995-06100	WASHER, SPRING ARANDELA		4		4		
18	6A0-45318-00	BUSHING, DRIVE SHAFT BUJE, EJE DE MANDO		1		1		L(21.6"),Y(23.5") L(21.6"),Y(23.5")
19	93420-36M01	CIRCLIP SEGURO		1		1		L(21.6"),Y(23.5") L(21.6"),Y(23.5")
20	6A0-45211-20-4D	EXTENSION EXTENSION		1				Y(23.5") Y(23.5")
21	93606-12019	PIN, DOWEL PASADOR DE CLAVIJA		2				Y(23.5") Y(23.5")
22	90116-08M12	BOLT, STUD ESPARRAGO		6				Y(23.5") Y(23.5")
23	92990-08100	WASHER, SPRING ARANDELA PLANA		6				Y(23.5") Y(23.5")
24	95380-08600	NUT TUERCA		6				Y(23.5") Y(23.5")
25	676-45151-00-4D	COVER, UPPER CASING CUBIERTA FUNDA SUPERIOR		1				S(16.6") S(16.6")
	676-45151-10-4D	COVER, UPPER CASING CUBIERTA FUNDA SUPERIOR		1	1	1		L(21.6"),Y(23.5") L(21.6"),Y(23.5")

FIG. 20 UPPER CASING 2

FUNDA SUPERIOR 2

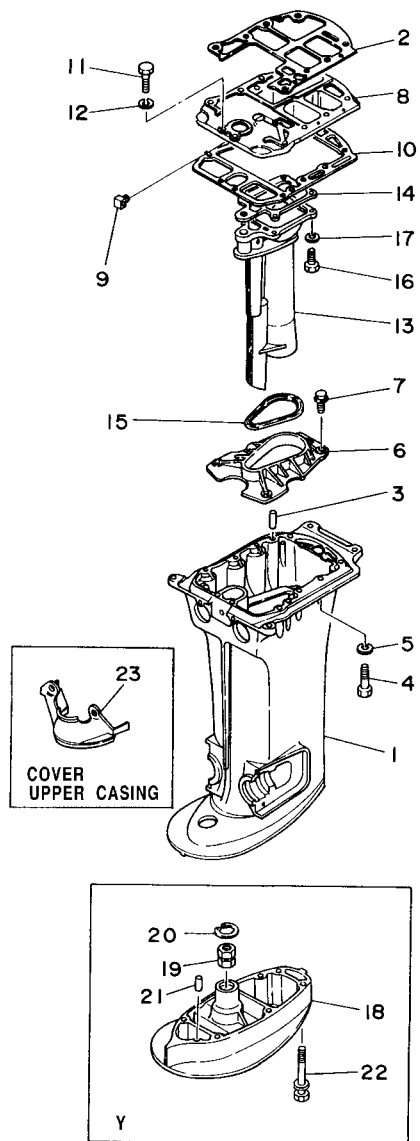

6J40200-4202

REF. NO.	PART NO. CODIGO Nº	DESCRIPTION DESCRIPCION	E40M	40MH	E40W	40WH	40W	REMARKS OBSERVACIONES
1	676-45111-03-4D	CASING, UPPER CAJA SUPERIOR	1					S(17.5") S(17.5")
	676-45111-15-4D	CASING, UPPER CAJA SUPERIOR	1	1				L(22.5"),Y(24.5") L(22.5"),Y(24.5")
2	6F5-45113-A0	GASKET, UPPER CASING EMPAQUE	1	1				
3	93606-25M00	PIN, DOWEL PASADOR DE CLAVIJA	2	2				
4	97095-08040	BOLT PERNO	8	8				
5	92995-08100	WASHER ARANDELA	8	8				
6	6F5-41116-00-5B	PROTECTOR PROTECTOR	1	1				
7	90105-06M01	BOLT, FLANGE TORNILLO	4	4				
8	6F5-41137-02-94	GUIDE, EXHAUST GUIA DE ESCAPE	1	1				
9	6F5-41141-00	ELBOW, WATER MIXING SELLO	1	1				
10	676-45114-A1	GASKET, UPPER CASING EMPAQUE	1	1				
11	97095-06025	BOLT PERNO	3	3				
12	92995-06100	WASHER, SPRING ARANDELA	3	3				
13	676-41131-01-5B	MANIFOLD, EXT. 1 TUBO MULTIPLE DE ESCAPE	1	1				
14	676-41133-A1	GASKET, EXHAUST MANIFOLD 1 EMPAQUE ESCAPE MULTIPLE	1	1				
15	676-45127-00	SEAL SELLO DE GOMA	1	1				
16	97095-06020	BOLT PERNO	4	4				
17	92995-06100	WASHER, SPRING ARANDELA	4	4				
18	676-45211-20-4D	EXTENSION EXTENSION	1					Y(24.5") Y(24.5")
19	679-45318-00	BUSHING, DRIVE SHAFT BUJE, EJE DE MANDO	1					Y(24.5") Y(24.5")
20	93420-30042	CIRCLIP SEGURO	1					Y(24.5") Y(24.5")
21	93606-12019	PIN, DOWEL PASADOR DE CLAVIJA	2					Y(24.5") Y(24.5")
22	97575-08480	BOLT, WITH WASHER PERNO CON ARANDELA	6					Y(24.5") Y(24.5")
23	676-45151-00-4D	COVER, UPPER CASING CUBIERTA FUNDA SUPERIOR	1					S(17.5") S(17.5")
	676-45151-10-4D	COVER, UPPER CASING CUBIERTA FUNDA SUPERIOR	1	1				L(22.5"),Y(24.5") L(22.5"),Y(24.5")

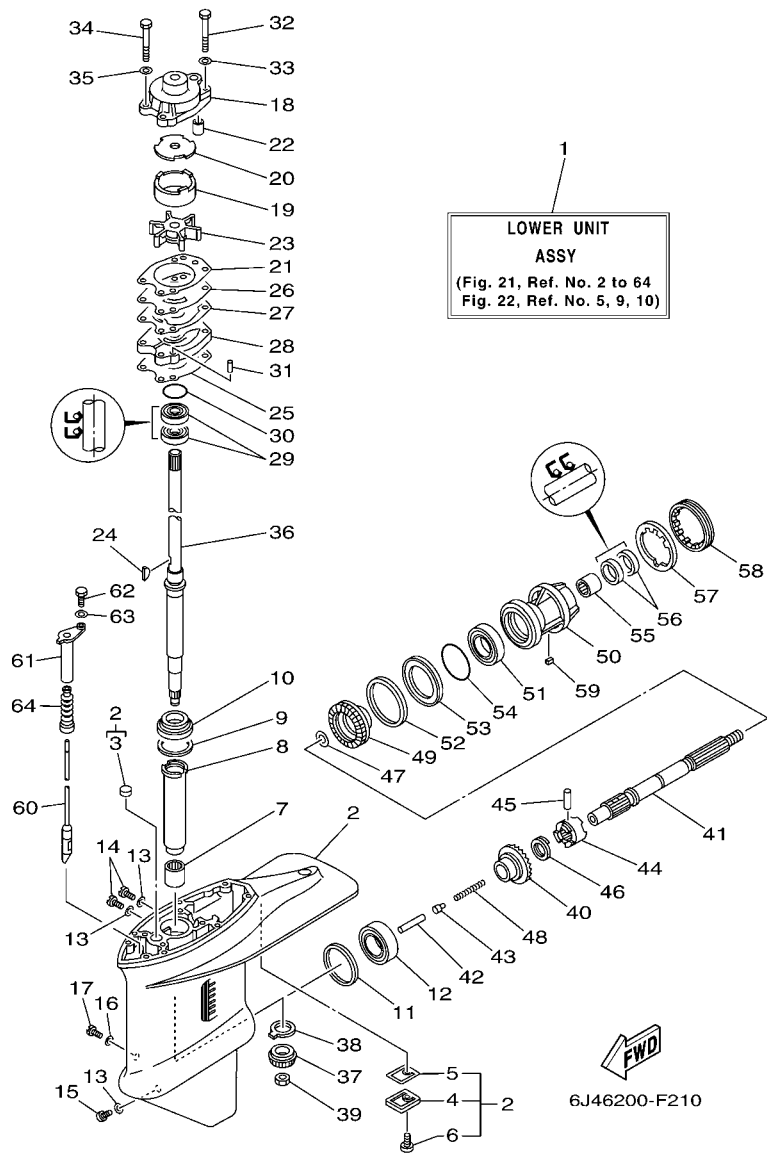
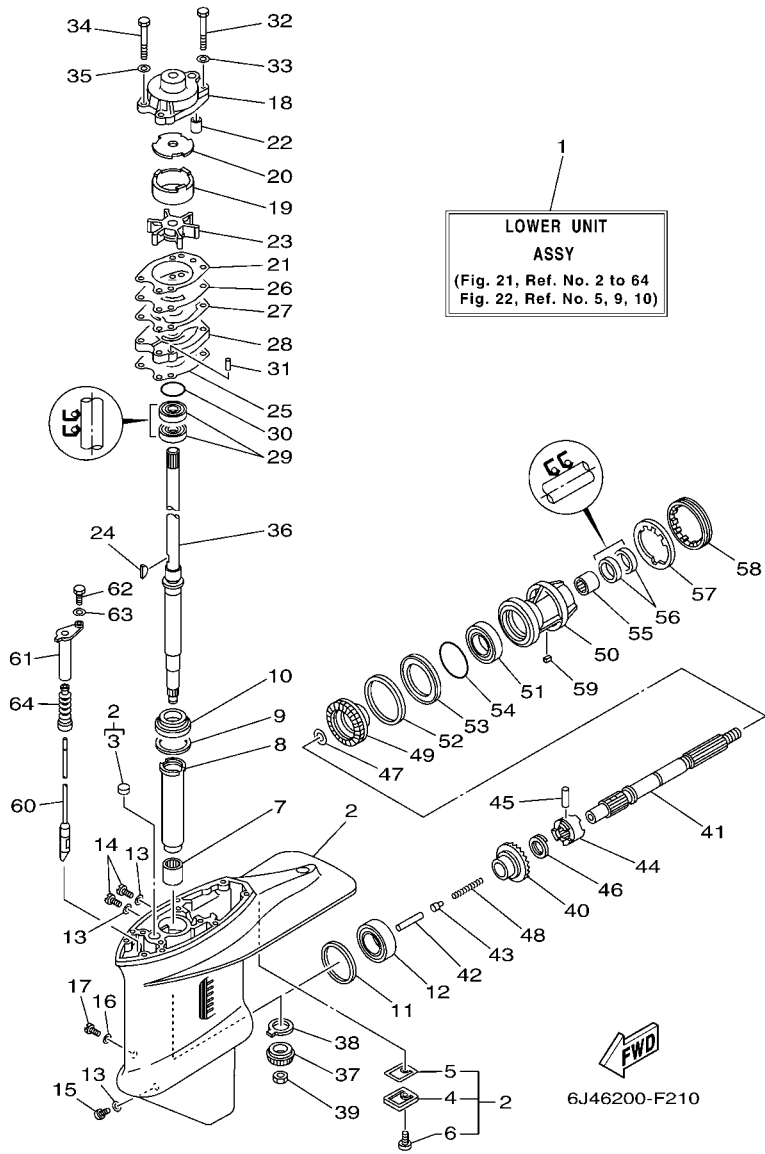

FIG. 21 LOWER CASING & DRIVE 1 IMPULSOR E INFERIOR 1

REF. NO.	PART NO. CODIGO Nº	DESCRIPTION DESCRIPCION	E40M	40MH	E40W	40WH	40W	REMARKS OBSERVACIONES
1	6J4-45300-02-4D	LOWER UNIT ASSY CONJUNTO UNIDAD INFERIOR		1				S(16.6") S(16.6")
	6J4-45300-12-4D	LOWER UNIT ASSY CONJUNTO UNIDAD INFERIOR		1		1	1	L(21.6") L(21.6")
	6J4-45300-22-4D	LOWER UNIT ASSY CONJUNTO UNIDAD INFERIOR		1				Y(23.5") Y(23.5")
	6H9-45300-12-4D	LOWER UNIT ASSY CONJUNTO UNIDAD INFERIOR		1				L(21.6")-FOR MYS L(21.6")-FOR MYS
2	6J4-W4531-01-4D	CASING, LOWER FUNDA INFERIOR		1		1	1	EXCEPT FOR MYS EXCEPT FOR MYS
	6H9-W4531-12-4D	CASING, LOWER FUNDA INFERIOR		1				FOR MYS FOR MYS
3	90338-22007	.PLUG .TAPON		1		1	1	
4	679-45321-02	.PLATE .PLACA		1		1	1	
5	679-45315-A1	.PACKING, LOWER CASING .EMPAQUE		1		1	1	
6	97880-06016	.SCREW, PAN HEAD .TORNILLO DE CABEZA CON PLANA		1		1	1	
7	93315-32224	BEARING COJINETE DE RODILLOS		1		1	1	
8	679-45536-00	SLEEVE, DRIVE SHAFT CAMISA EJE DE MANDO		1		1	1	
9	663-45587-01	SHIM (T:0.10MM) LAINA (T:0.10MM)		1		1	1	UR UR
	663-45587-10	SHIM (T:0.12MM) LAINA (T:0.12MM)		1		1	1	UR UR
	663-45587-20	SHIM (T:0.15MM) LAINA (T:0.15MM)		1		1	1	UR UR
	663-45587-30	SHIM (T:0.18MM) LAINA (T:0.18MM)		1		1	1	UR UR
	663-45587-40	SHIM (T:0.30MM) LAINA (T:0.30MM)		1		1	1	UR UR
	663-45587-50	SHIM (T:0.40MM) LAINA (T:0.40MM)		1		1	1	UR UR
	663-45587-60	SHIM (T:0.50MM) LAINA (T:0.50MM)		1		1	1	UR UR
10	93332-00001	BEARING COJINETE		1		1	1	
11	663-45567-01	SHIM (T:0.10MM) LAINA (T:0.10MM)		1		1	1	UR UR
	663-45567-10	SHIM (T:0.12MM) LAINA (T:0.12MM)		1		1	1	UR UR
	663-45567-20	SHIM (T:0.15MM) LAINA (T:0.15MM)		1		1	1	UR UR
	663-45567-30	SHIM (T:0.18MM) LAINA (T:0.18MM)		1		1	1	UR UR
	663-45567-40	SHIM (T:0.30MM) LAINA (T:0.30MM)		1		1	1	UR UR
	663-45567-50	SHIM (T:0.40MM) LAINA (T:0.40MM)		1		1	1	UR UR
	663-45567-60	SHIM (T:0.50MM) LAINA (T:0.50MM)		1		1	1	UR UR



1
**LOWER UNIT
 ASSY**
 (Fig. 21, Ref. No. 2 to 64
 Fig. 22, Ref. No. 5, 9, 10)

FIG. 21 LOWER CASING & DRIVE 1 IMPULSOR E INFERIOR 1

REF. NO.	PART NO. CODIGO Nº	DESCRIPTION DESCRIPCION	E40M	40MH	E40W	40WH	40W	REMARKS OBSERVACIONES
12	93332-00003	BEARING COJINETE		1		1	1	
13	90430-08020	GASKET JUNTA		3		3	3	
14	90340-08002	PLUG, STRAIGHT SCREW TORNILLO, DE DRENAJE		2		2	2	
15	688-45341-10	PLUG, DRAIN TAPON, DREN		1		1	1	
16	90430-06M03	GASKET JUNTA		1		1	1	
17	90149-06M00	SCREW TORNILLO DE REGLAJE		1		1	1	
18	676-44311-00	HOUSING, WATER PUMP CAJA BOMBA DE AGUA		1		1	1	
19	676-44322-40	INSERT, CARTRIDGE CARTUCHO		1		1	1	FOR CHROMATE FOR CHROMATE
20	676-44321-40	INNER PLATE, CARTRIDGE PLACA INTERIOR CARTUCHO		1		1	1	FOR CHROMATE FOR CHROMATE
21	676-44315-A1	GASKET, WATER PUMP EMPAQUE		1		1	1	
22	663-44366-00	DAMPER, WATER SEAL GOMA DEL SELLO DE AGUA		1		1	1	
23	6F5-44352-00	IMPELLER IMPULSOR		1		1	1	
24	90280-04M00	KEY, WOODRUFF CUNA WOODRUFF		1		1	1	
25	679-44316-A1	GASKET, WATER PUMP EMPAQUE		1		1	1	
26	676-44323-40	OUTER PLATE, CARTRIDGE PLACA EXTERIOR DEL CARTUCHO		1		1	1	FOR CHROMATE FOR CHROMATE
27	676-44324-A1	GASKET, CARTRIDGE EMPAQUE		1		1	1	
28	679-44341-00-94	HOUSING, WATER PUMP CAJA BOMBA DE AGUA		1		1	1	
29	93101-22M00	OIL SEAL SELLO ACEITE		2		2	2	
30	93210-41042	O-RING ANILLO O		1		1	1	
31	93604-08062	PIN, DOWEL PASADOR DE CLAVIJA		2		2	2	
32	97095-08055	BOLT PERNO		2		2	2	
33	92995-08600	WASHER ARANDELA		2		2	2	
34	97095-08045	BOLT PERNO		2		2	2	
35	92995-08600	WASHER ARANDELA		2		2	2	
36	679-45501-00	DRIVE SHAFT COMP. EJE DE MANDO COMPL.		1				S(16.6") S(16.6")
	679-45501-10	DRIVE SHAFT COMP. EJE DE MANDO COMPL.		1		1	1	L(21.6") L(21.6")
	6A0-45501-20	DRIVE SHAFT COMP. EJE DE MANDO COMPL.		1				Y(23.5") Y(23.5")

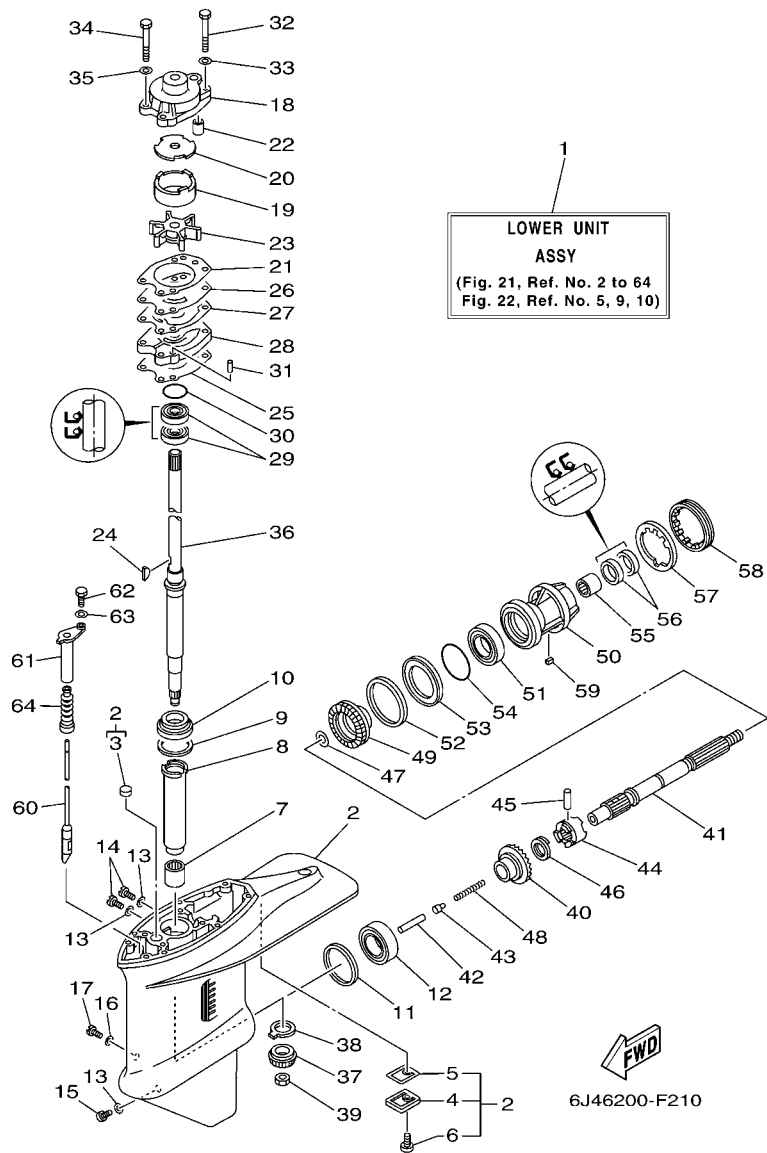

FIG. 21 LOWER CASING & DRIVE 1 IMPULSOR E INFERIOR 1

REF. NO.	PART NO. CODIGO Nº	DESCRIPTION DESCRIPCION	E40M	40MH	E40W	40WH	40W	REMARKS OBSERVACIONES
37	6H9-45551-00	PINION (13T) PINON (13T)		1		1	1	
38	663-45552-00	BEARING, PLAIN COJINETE PLANO		1		1	1	
39	90170-12138	NUT TUERCA		1		1	1	
40	679-45560-00	GEAR 1 (26T) ENGRANAJE 1 (26T)		1		1	1	
41	679-45611-01	SHAFT, PROPELLER EJE PROPUSOR		1		1	1	
42	676-45635-00	PLUNGER, SHIFT EMBOLO DE CAMBIO		1		1	1	
43	663-45634-00	SLIDE, SHIFT DESLIZADOR, CAMBIO		1		1	1	
44	663-45631-01	CLUTCH, DOG EMBRAGUE DE GARRA		1		1	1	
45	90250-06023	PIN, STRAIGHT PASADOR CILINDRICO		1		1	1	
46	663-45633-00	RING, CROSS PIN ANILLO DE PASADOR		1		1	1	
47	90201-22429	WASHER, PLATE ARANDELA PLANA		1		1	1	
48	90501-16M01	SPRING, COMPRESSION RESORTE DE COMPRESION		1		1	1	
49	679-45571-00	GEAR 2 (26T) ENGRANAJE 2 (26T)		1		1	1	
50	679-45331-00-94	HOUSING, BEARING CAJA DE COJINETE		1		1	1	
51	93306-00702	BEARING COJINETE		1		1	1	
52	663-45577-01	SHIM (T:0.10MM) LAINA (T:0.10MM)		1		1	1	UR
	663-45577-10	SHIM (T:0.12MM) LAINA (:0.12MM)		1		1	1	UR
	663-45577-20	SHIM (T:0.15MM) LAINA (T:0.15MM)		1		1	1	UR
	663-45577-30	SHIM (T:0.18MM) LAINA (T:0.18MM)		1		1	1	UR
	663-45577-40	SHIM (T:0.30MM) LAINA (T:0.30MM)		1		1	1	UR
	663-45577-50	SHIM (T:0.40MM) LAINA (T:0.40MM)		1		1	1	UR
	663-45577-60	SHIM (T:0.50MM) LAINA (T:0.50MM)		1		1	1	UR
53	663-45576-00	WASHER, THRUST ARANDELA DE EMPUJE AXIAL		1		1	1	
54	93210-66M98	O-RING ANILLO O		1		1	1	
55	93317-22204	BEARING COJINETE		1		1	1	
56	93101-22M00	OIL SEAL SELLO ACEITE		2		2	2	
57	90214-48M03	WASHER, CLAW ARANDELA DE POSICION		1		1	1	

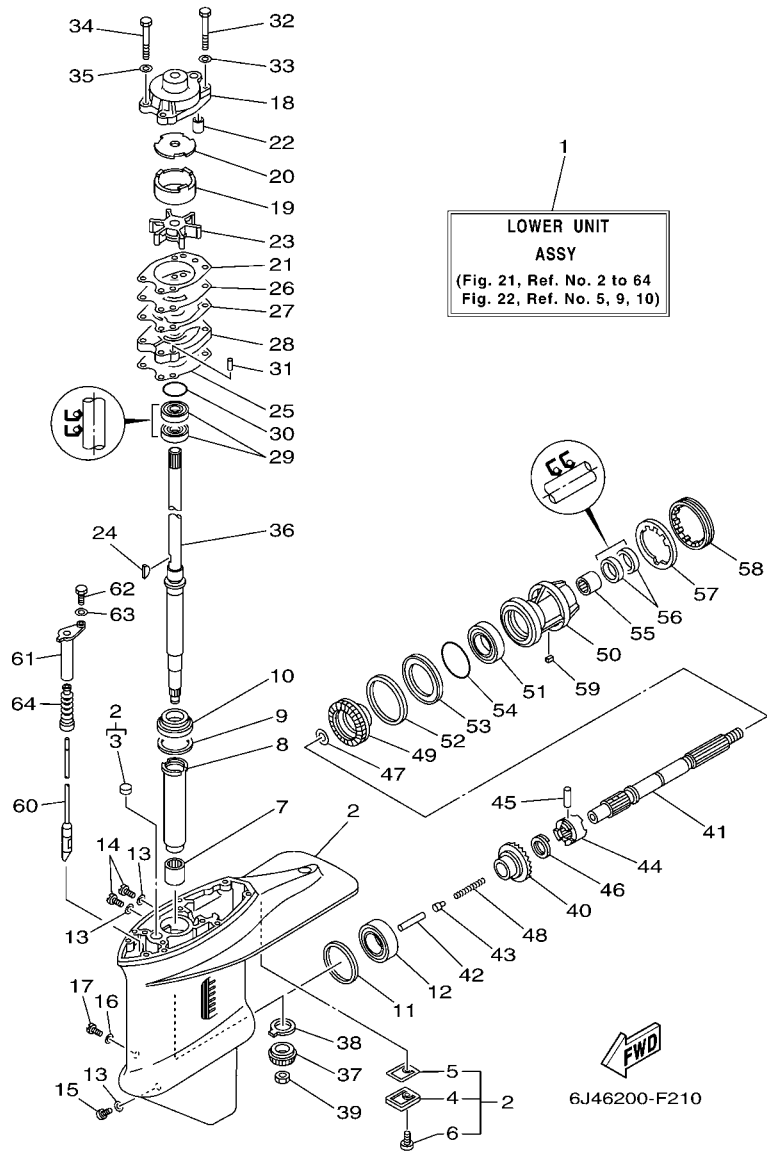
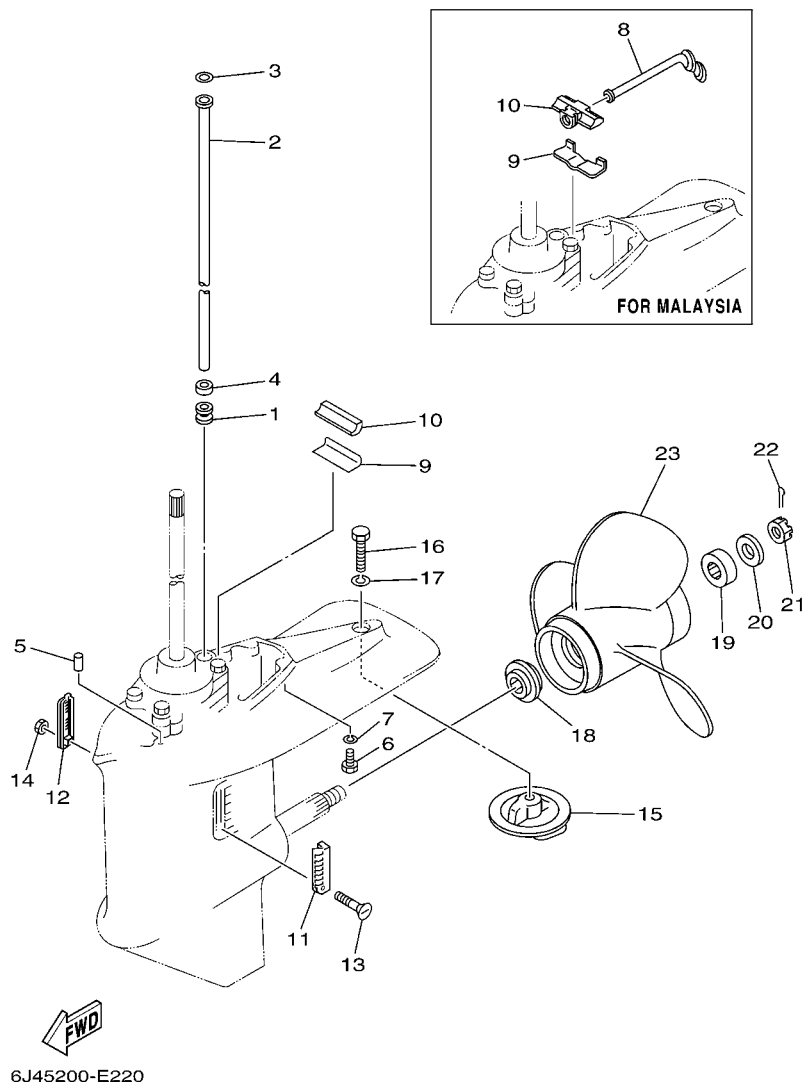

FIG. 21 LOWER CASING & DRIVE 1 IMPULSOR E INFERIOR 1

REF. NO.	PART NO. CODIGO Nº	DESCRIPTION DESCRIPCION	E40M	40MH	E40W	40WH	40W	REMARKS OBSERVACIONES
58	697-45384-00	NUT TUERCA		1		1	1	
59	90282-04010	KEY, STRAIGHT CHAVETA, RECTA		1		1	1	
60	679-44150-00	SHIFT CAM ASSY CONJUNTO EJE LEVA COMPL.		1				S(16.6") S(16.6")
	679-44150-10	SHIFT CAM ASSY CONJUNTO EJE LEVA COMPL.		1		1	1	L(21.6") L(21.6")
	6A0-44150-20	SHIFT CAM ASSY CONJUNTO EJE LEVA COMPL.		1				Y(23.5") Y(23.5")
61	679-44152-00	BUSHING, SHIFT CAM BUJE LEVA DE CAMBIO		1		1	1	
62	97095-06018	BOLT PERNO		1		1	1	
63	92995-06600	WASHER ARANDELA		1		1	1	
64	650-44147-00	BOOT, SHIFT ROD HULE DE VARILLA		1		1	1	

FIG. 22 LOWER CASING & DRIVE 2

IMPULSOR E INFERIOR 2



REF. NO.	PART NO. CODIGO Nº	DESCRIPTION DESCRIPCION	E40M	40MH	E40W	40WH	40W	REMARKS OBSERVACIONES
1	663-44367-00	DAMPER, WATER SEAL GOMA DEL SELLO DE AGUA		1		1	1	
2	676-44361-00	TUBE, WATER TUBO DE AGUA		1				S(16.6") S(16.6")
	676-44361-10	TUBE, WATER TUBO DE AGUA		1		1	1	L(21.6") L(21.6")
	6A0-44361-20	TUBE, WATER TUBO DE AGUA		1				Y(23.5") Y(23.5")
3	90202-12060	WASHER, PLATE ARANDELA DE PLANA		1		1	1	
4	90430-12072	GASKET JUNTA		1		1	1	
5	93606-12019	PIN, DOWEL PASADOR DE CLAVIJA		2		2	2	
6	97075-08030	BOLT PERNO		6		6	6	S(16.6"),L(21.6") S(16.6"),L(21.6")
7	92995-08100	WASHER ARANDELA		6		6	6	S(16.6"),L(21.6") S(16.6"),L(21.6")
8	6H9-44362-00	TUBE, WATER TUBO DE AGUA		1				FOR MYS FOR MYS
9	663-45376-00-94	GUIDE, SEAL DAMPER GUIA DE SELLO GOMA		1		1	1	EXCEPT FOR MYS EXCEPT FOR MYS
	6H9-45376-00	GUIDE, SEAL DAMPER GUIA DE SELLO GOMA		1				FOR MYS FOR MYS
10	663-45375-00	DAMPER, SEAL GOMA DE SELLO		1		1	1	EXCEPT FOR MYS EXCEPT FOR MYS
	6H9-45375-00	DAMPER, SEAL GOMA DE SELLO		1				FOR MYS FOR MYS
11	688-45214-02	COVER, WATER INLET 1 CUBIERTA ENTRADA AGUA 1		1		1	1	
12	688-45215-02	COVER, WATER INLET 2 CUBIERTA ENTRADA AGUA 2		1		1	1	
13	90152-05M09	SCREW, COUNTERSUNK TORNILLO EMBUTIDO		1		1	1	
14	90185-05002	NUT, SELF-LOCKING TUERCA AUTOBLOCANTE		1		1	1	
15	679-45371-00	TAB-TRIM QUILLA ESTABILIZADOR		1		1	1	
16	97095-10030	BOLT PERNO		1		1	1	
17	92995-10100	WASHER ARANDELA		1		1	1	
18	663-45987-02	SPACER ESPACIADOR		1		1	1	
19	670-45997-02	SPACER ESPACIADOR		1		1	1	
20	92990-16200	WASHER, PLAIN ARANDELA PLANA		1		1	1	
21	90171-16011	NUT, CASTLE TUERCA ENTALLADA		1		1	1	
22	91490-30025	PIN, COTTER CHAVETA		1		1	1	
23	69W-45943-00-EL	PROPELLER (3X11"X15"-G) PROPELA (3X11"X15"-G)		1		1	1	UR UR

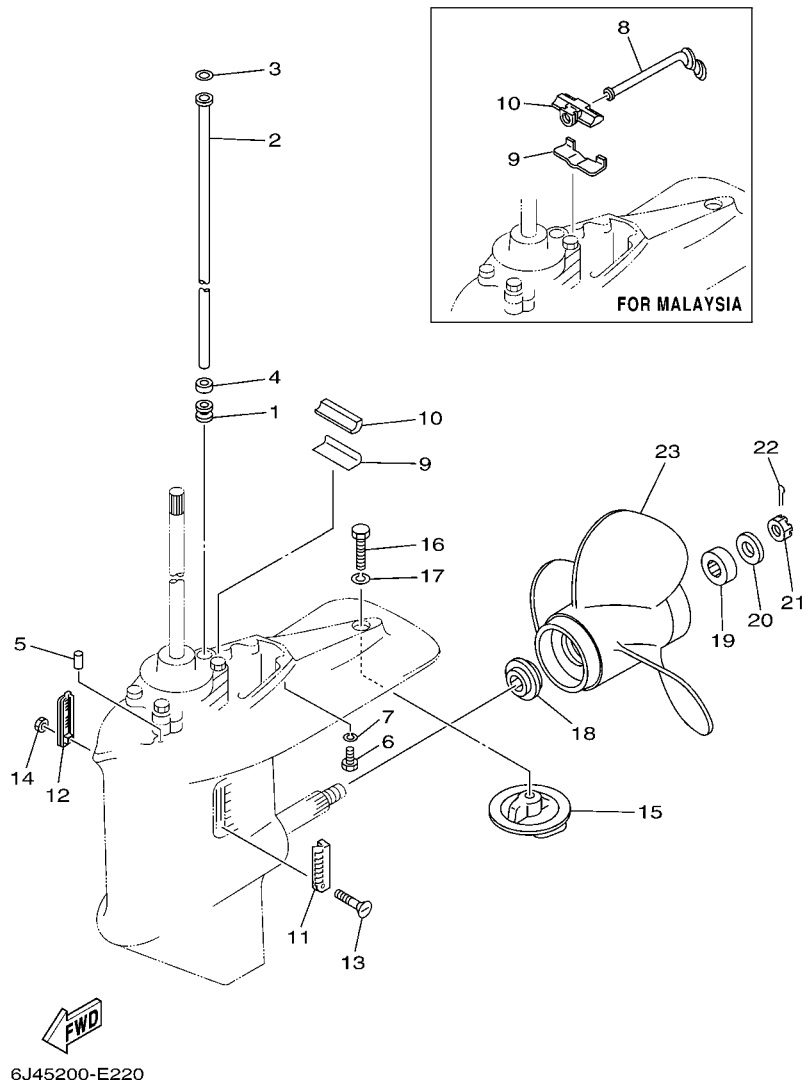

FIG. 22 LOWER CASING & DRIVE 2 IMPULSOR E INFERIOR 2

REF. NO.	PART NO. CODIGO Nº	DESCRIPTION DESCRIPCION	E40M	40MH	E40W	40WH	40W	REMARKS OBSERVACIONES
23	69W-45945-00-EL	PROPELLER (3X11-1/8"X13"-G) PROPELA (3X11-1/8"X13"-G)		1		1	1	UR UR
	69W-45947-00-EL	PROPELLER (3X11-5/8"X11"-G) PROPELA (3X11-5/8"X11"-G)		1		1	1	UR UR
	69W-45952-00-EL	PROPELLER (3X11-3/8"X12"-G) PROPELA (3X11-3/8"X12"-G)		1		1	1	UR UR
	663-45941-01-EL	PROPELLER (3X10-3/4"X17"-G) PROPELA (3X10-3/4"X17"-G)		1		1	1	UR UR
	663-45949-01-EL	PROPELLER (3X10-3/4"X16"-G) PROPELA (3X10-3/4"X16"-G)		1		1	1	UR UR
	663-45952-02-EL	PROPELLER (3X11-3/8"X12"-G) PROPELA (3X11-3/8"X12"-G)		1		1	1	UR UR
	663-45954-01-EL	PROPELLER (3X11-3/4"X10"-G) PROPELA (3X11-3/4"X10"-G)		1		1	1	UR UR
	663-45956-01-EL	PROPELLER (3X12-1/4"X9"-G) PROPELA (3X12-1/4"X9"-G)		1		1	1	UR UR
	663-45958-01-EL	PROPELLER (3X11-1/4"X14"-G) PROPELA (3X11-1/4"X14"-G)		1		1	1	UR UR
	663-45930-00-98	PROPELLER (3X10-1/4"X14"-G) PROPELA (3X10-1/4"X14"-G)		1		1	1	UR UR
	663-45976-00-98	PROPELLER (3X10-1/4"X15"-G) PROPELA (3X10-1/4"X15"-G)		1		1	1	UR UR
	663-45978-00-98	PROPELLER (3X10-1/4"X16"-G) PROPELA (3X10-1/4"X16"-G)		1		1	1	UR UR
	663-45970-60-98	PROPELLER (3X11-3/4"X12"-G) PROPELA (3X11-3/4"X12"-G)		1		1	1	UR UR
	663-45972-60-98	PROPELLER (3X12"X11"-G) PROPELA (3X12"X11"-G)		1		1	1	UR UR
	663-45974-60-98	PROPELLER (3X11-1/2"X13"-G) PROPELA (3X11-1/2"X13"-G)		1		1	1	UR UR

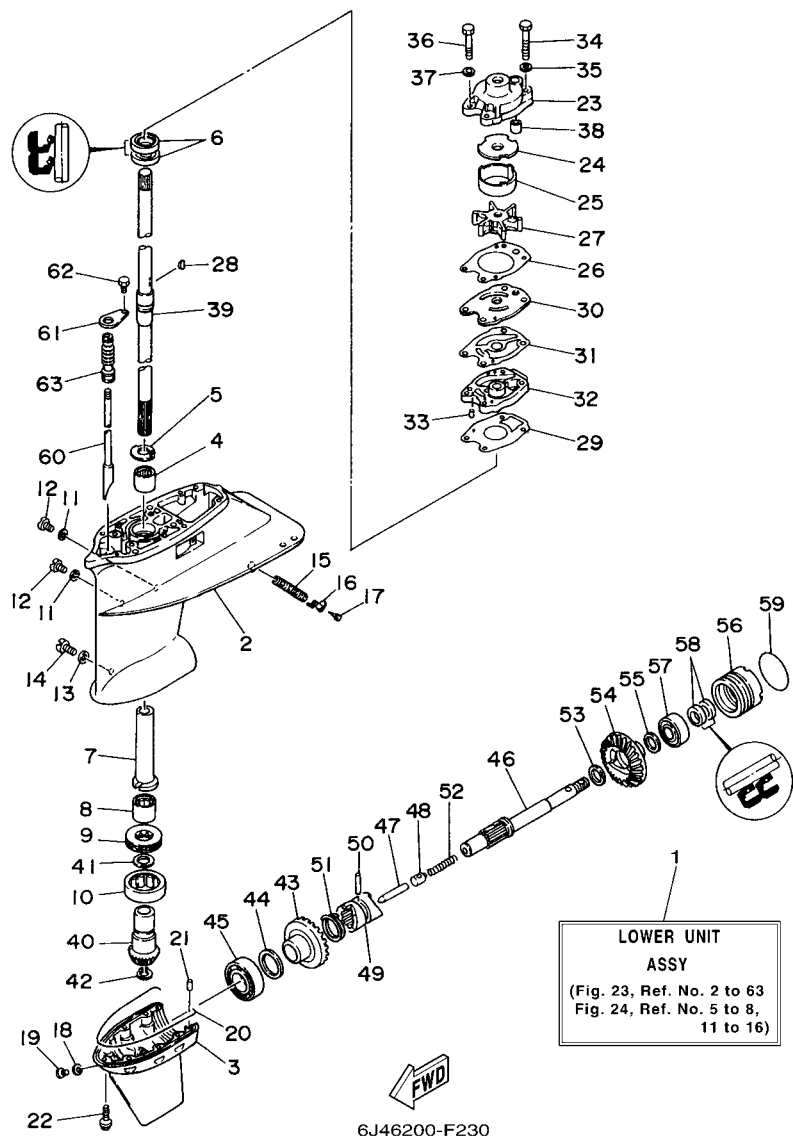

FIG. 23 LOWER CASING & DRIVE 3 IMPULSOR E INFERIOR 3

REF. NO.	PART NO. CODIGO Nº	DESCRIPTION DESCRIPCION	E40M	40MH	E40W	40WH	40W	REMARKS OBSERVACIONES
1	6F6-45300-02-4D	LOWER UNIT ASSY CONJUNTO UNIDAD INFERIOR	1					S(17.5") S(17.5")
	6F6-45300-12-4D	LOWER UNIT ASSY CONJUNTO UNIDAD INFERIOR	1		1			L(22.5") L(22.5")
	6F6-45300-22-4D	LOWER UNIT ASSY CONJUNTO UNIDAD INFERIOR	1					Y(24.5") Y(24.5")
2	6F5-45311-02-4D	CASING, LOWER FUNDA INFERIOR				1		
3	6F5-45312-01-4D	CASING, LOWER FUNDA INFERIOR				1		
4	93315-217U0	BEARING COJINETE DE RODILLOS				1		
5	676-45533-00	SHIM ARANDELA DE EMPUJE AXIAL				1		
6	93101-22M00	OIL SEAL SELLO ACEITE				2		
7	676-45536-00	SLEEVE, DRIVE SHAFT CAMISA EJE DE MANDO				1		
8	93315-324U1	BEARING COJINETE DE RODILLOS				1		
9	93342-624U0	BEARING COJINETES CON RODAMIENTOS				1		
10	93390-000U0	BEARING COJINETE DE RODILLOS				1		
11	90430-08020	GASKET JUNTA				2		
12	90340-08002	PLUG, STRAIGHT SCREW TORNILLO, DE DRENAJE				2		
13	90430-06M03	GASKET JUNTA				1		
14	90149-06M00	SCREW TORNILLO DE REGLAJE				1		
15	676-45215-01	COVER, WATER INLET 2 CUBIERTA ENTRADA AGUA 2				1		
16	6F5-45279-01	CAP TAPA				1		
17	97780-60525	SCREW, TAPPING TORNILLO DE CABEZA DE CONO ACH				1		
18	90430-08020	GASKET JUNTA				1		
19	688-45341-10	PLUG, DRAIN TAPON, DREN				1		
20	676-45314-00	SEAL, LOWER CASING SELLO DE FUNDA INFERIOR				1		
21	93604-09068	PIN, DOWEL PASADOR DE CLAVIJA				1		
22	90105-06M01	BOLT, FLANGE TORNILLO				9		
23	676-44311-00	HOUSING, WATER PUMP CAJA BOMBA DE AGUA				1		
24	676-44321-40	INNER PLATE, CARTRIDGE PLACA INTERIOR CARTUCHO				1		FOR CHROMATE FOR CHROMATE
25	676-44322-40	INSERT, CARTRIDGE CARTUCHO				1		FOR CHROMATE FOR CHROMATE

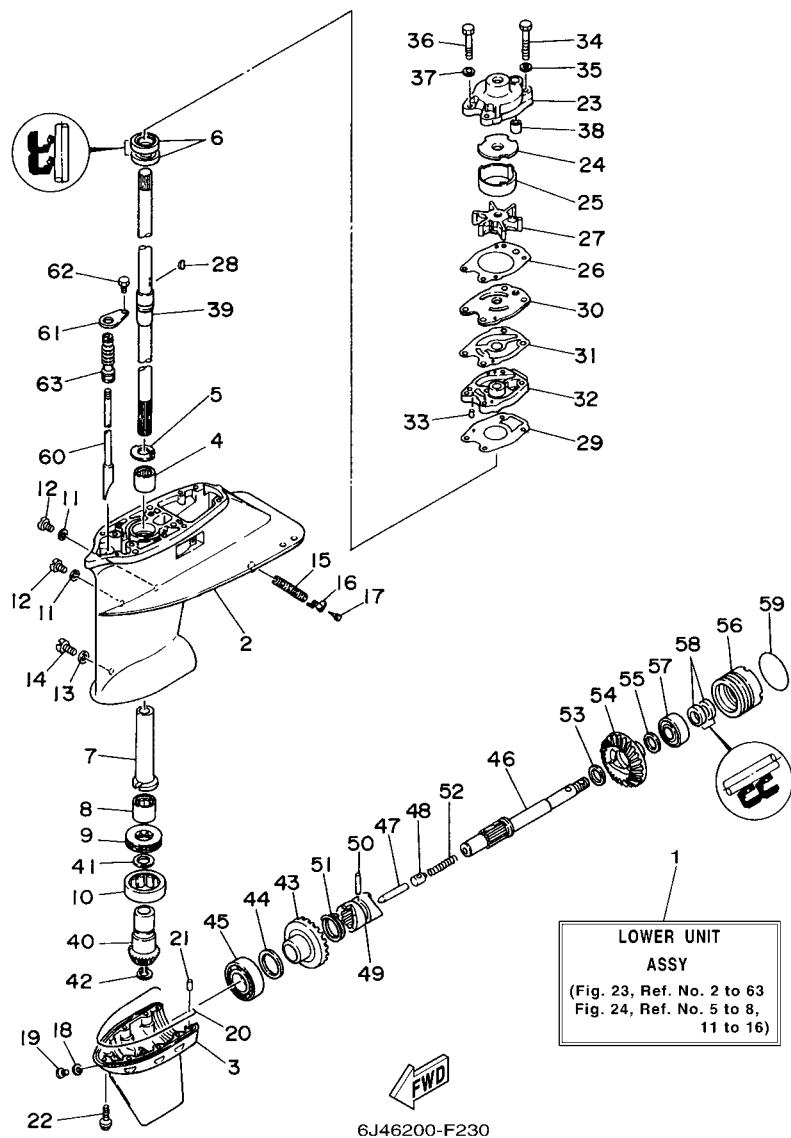

FIG. 23 LOWER CASING & DRIVE 3 IMPULSOR E INFERIOR 3

REF. NO.	PART NO. CODIGO Nº	DESCRIPTION DESCRIPCION	E40M	40MH	E40W	40WH	40W	REMARKS OBSERVACIONES
26	676-44315-A1	GASKET, WATER PUMP EMPAQUE	1		1			
27	6F5-44352-00	IMPELLER IMPULSOR	1		1			
28	90280-04M00	KEY, WOODRUFF CUNA WOODRUFF	1		1			
29	676-44316-A1	GASKET, WATER PUMP EMPAQUE	1		1			
30	676-44323-40	OUTER PLATE, CARTRIDGE PLACA EXTERIOR DEL CARTUCHO	1		1			FOR CHROMATE FOR CHROMATE
31	676-44324-A1	GASKET, CARTRIDGE EMPAQUE	1		1			
32	676-44341-01-94	HOUSING, WATER PUMP CAJA BOMBA DE AGUA	1		1			
33	93604-08062	PIN, DOWEL PASADOR DE CLAVIJA	3		3			
34	97095-08055	BOLT PERNO	2		2			
35	92995-08600	WASHER ARANDELA	2		2			
36	97095-08045	BOLT PERNO	2		2			
37	92995-08600	WASHER ARANDELA	2		2			
38	663-44366-00	DAMPER, WATER SEAL GOMA DEL SELLO DE AGUA	1		1			
39	676-45501-00	DRIVE SHAFT COMP. EJE DE MANDO COMPL.	1					S(17.5") S(17.5")
	676-45501-10	DRIVE SHAFT COMP. EJE DE MANDO COMPL.	1		1			L(22.5") L(22.5")
	676-45501-20	DRIVE SHAFT COMP. EJE DE MANDO COMPL.	1					Y(24.5") Y(24.5")
40	6F5-45551-01	PINION (13T) PINON (13T)	1		1			
41	676-45587-00	SHIM (T:0.70MM) LAINA (T:0.70MM)	1		1			UR UR
	676-45587-10	SHIM (T:0.75MM) LAINA (T:0.75MM)	1		1			UR UR
	676-45587-20	SHIM (T:0.80MM) LAINA (T:0.80MM)	1		1			UR UR
	676-45587-30	SHIM (T:0.85MM) LAINA (T:0.85MM)	1		1			UR UR
42	93410-16007	CIRCLIP SEGURO	1		1			
43	6F5-45560-01	GEAR 1 (24T) ENGRANAJE 1 (24T)	1		1			
44	676-45567-00	SHIM (T:0.7MM) LAINA (T:0.7MM)	1		1			UR UR
	676-45567-10	SHIM (T:0.8MM) LAINA (T:0.8MM)	1		1			UR UR
	676-45567-20	SHIM (T:0.9MM) LAINA (T:0.9MM)	1		1			UR UR
	676-45567-30	SHIM (T:1.0MM) LAINA (T:1.0MM)	1		1			UR UR

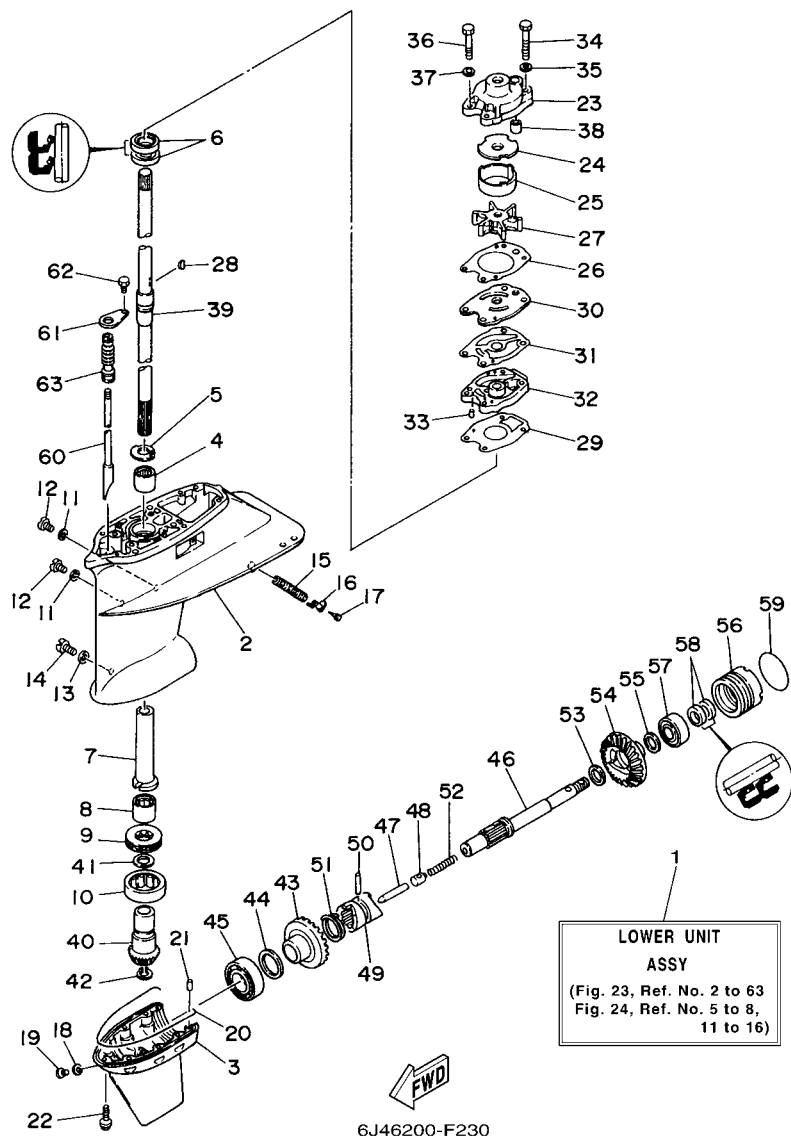
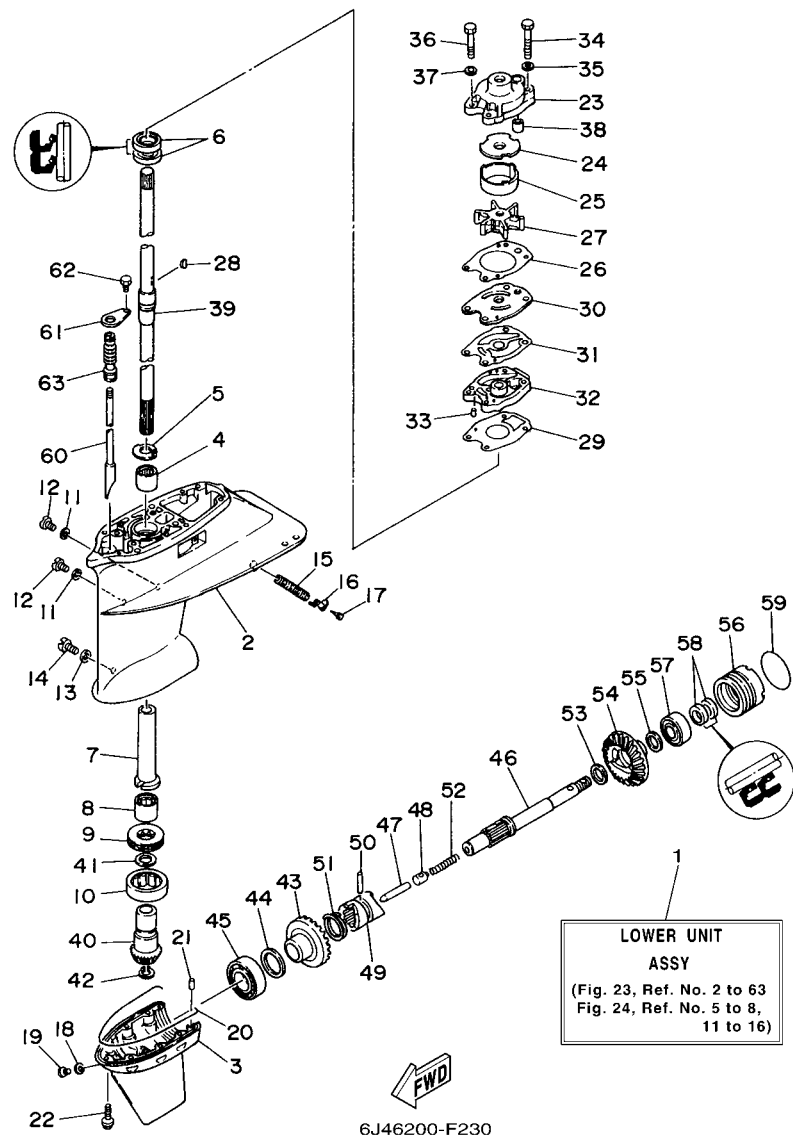

FIG. 23 LOWER CASING & DRIVE 3 IMPULSOR E INFERIOR 3

REF. NO.	PART NO. CODIGO Nº	DESCRIPTION DESCRIPCION	E40M	40MH	E40W	40WH	40W	REMARKS OBSERVACIONES
44	676-45567-40	SHIM (T:1.1MM) LAINA (T:1.1MM)	1		1			UR UR
	676-45567-50	SHIM (T:1.2MM) LAINA (T:1.2MM)	1		1			UR UR
45	93332-000U0	BEARING COJINETE	1		1			
46	6F6-45611-00	SHAFT, PROPELLER EJE PROPUSOR	1		1			
47	676-45635-00	PLUNGER, SHIFT EMBOLO DE CAMBIO	1		1			
48	663-45634-00	SLIDE, SHIFT DESILIZADOR, CAMBIO	1		1			
49	663-45631-01	CLUTCH, DOG EMBRAGUE DE GARRA	1		1			
50	90250-06023	PIN, STRAIGHT PASADOR CILINDRICO	1		1			
51	663-45633-00	RING, CROSS PIN ANILLO DE PASADOR	1		1			
52	90501-16M01	SPRING, COMPRESSION RESORTE DE COMPRESION	1		1			
53	90201-20MA8	WASHER, PLATE ARANDELA PLANA	1		1			
54	6F5-45570-00	GEAR 2 (24T) ENGRANAJE 2 (24T)	1		1			
55	676-45577-00	SHIM (T:1.8MM) LAINA (T:1.8MM)	1		1			UR UR
	676-45577-10	SHIM (T:1.9MM) LAINA (T:1.9MM)	1		1			UR UR
	676-45577-20	SHIM (T:2.0MM) LAINA (T:2.0MM)	1		1			UR UR
	676-45577-30	SHIM (T:2.1MM) LAINA (T:2.1MM)	1		1			UR UR
	676-45577-40	SHIM (T:2.2MM) LAINA (T:2.2MM)	1		1			UR UR
	676-45577-50	SHIM (T:2.3MM) LAINA (T:2.3MM)	1		1			UR UR
	676-45577-60	SHIM (T:2.4MM) LAINA (T:2.4MM)	1		1			UR UR
	676-45577-70	SHIM (T:2.5MM) LAINA (T:2.5MM)	1		1			UR UR
56	676-45361-01-94	CAP, LOWER CASING FUNDA INFERIOR	1		1			
57	93306-20401	BEARING COJINETE	1		1			
58	93101-20048	OIL SEAL SELLO ACEITE	2		2			
59	93210-57M00	O-RING ANILLO O	1		1			
60	676-44150-00	SHIFT CAM ASSY CONJUNTO EJE LEVA COMPL.	1					S(17.5") S(17.5")
	676-44150-10	SHIFT CAM ASSY CONJUNTO EJE LEVA COMPL.	1		1			L(22.5") L(22.5")
	676-44150-20	SHIFT CAM ASSY CONJUNTO EJE LEVA COMPL.	1					Y(24.5") Y(24.5")

FIG. 23 LOWER CASING & DRIVE 3

IMPULSOR E INFERIOR 3



REF. NO.	PART NO. CODIGO Nº	DESCRIPTION DESCRIPCION	E40M	40MH	E40W	40WH	40W	REMARKS OBSERVACIONES
61	650-45321-00	PLATE PLACA	1		1			
62	97095-06010	BOLT PERNO	1		1			
63	650-44147-00	BOOT, SHIFT ROD HULE DE VARILLA	1		1			

FIG. 24 LOWER CASING & DRIVE 4

IMPULSOR E INFERIOR 4

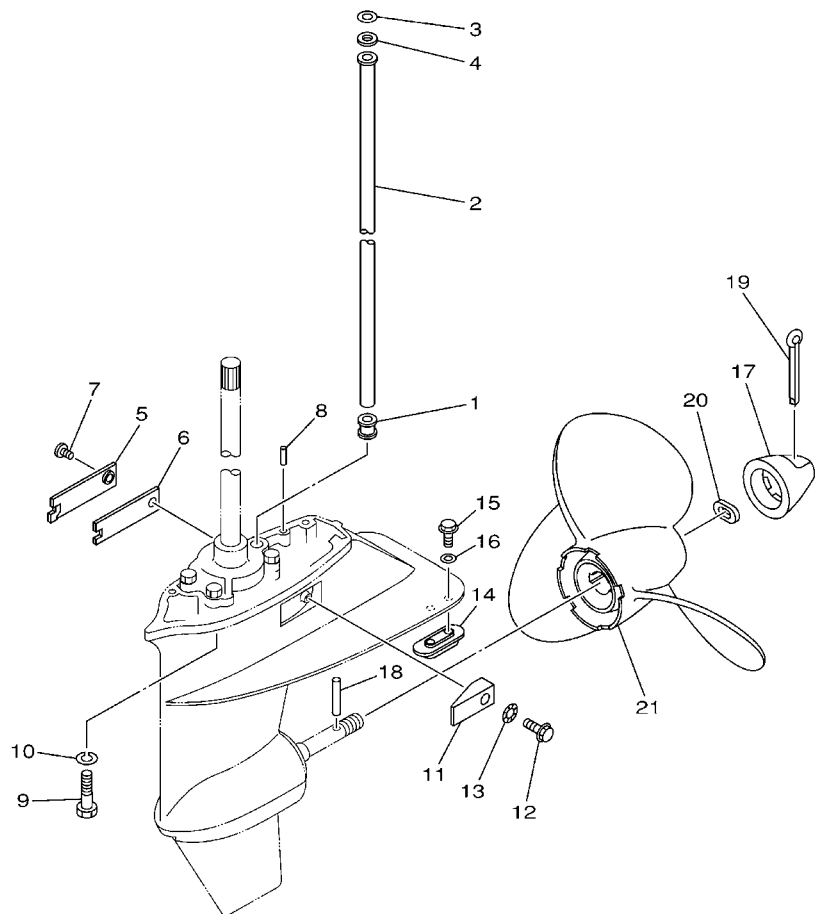



6J40200-1240

REF. NO.	PART NO. CODIGO Nº	DESCRIPTION DESCRIPCION	E40M	40MH	E40W	40WH	40W	REMARKS OBSERVACIONES
1	663-44367-00	DAMPER, WATER SEAL GOMA DEL SELLO DE AGUA	1		1			
2	676-44361-00	TUBE, WATER TUBO DE AGUA	1					S(17.5") S(17.5")
	676-44361-10	TUBE, WATER TUBO DE AGUA	1		1			L(22.5") L(22.5")
	676-44361-20	TUBE, WATER TUBO DE AGUA	1					Y(24.5") Y(24.5")
3	90202-12060	WASHER, PLATE ARANDELA DE PLANA	1		1			
4	90430-12072	GASKET JUNTA	1		1			
5	6F5-45214-00	COVER, WATER INLET 1 CUBIERTA ENTRADA AGUA 1	1		1			
6	6F5-45252-00	SEAT ASIENTO	1		1			
7	90152-06M06	SCREW, COUNTERSUNK TORNILLO EMBUTIDO	1		1			
8	93606-12019	PIN, DOWEL PASADOR DE CLAVIJA	2		2			
9	97075-08030	BOLT PERNO	6		6			S(17.5"),L(22.5") S(17.5"),L(22.5")
10	92995-08100	WASHER ARANDELA	6		6			S(17.5"),L(22.5") S(17.5"),L(22.5")
11	6F5-45251-02	ANODE CATODE	1		1			
12	90105-06M21	BOLT, FLANGE TORNILLO	1		1			
13	92990-06300	WASHER, INTERNAL TOOTH ARANDELA PLANA	1		1			
14	6E0-45251-12	ANODE CATODE	1		1			
15	95895-06016	BOLT, FLANGE TORNILLO DE REBORDE	2		2			
16	92990-06300	WASHER, INTERNAL TOOTH ARANDELA PLANA	2		2			
17	676-45616-01	NUT, PROPELLER TUERCA DE HELICE	1		1			
18	6F6-45614-00	PIN, DRIVE PASADOR	1		1			
19	91490-40040	PIN, COTTER CHAVETA	1		1			
20	90206-16M03	WASHER, WAVE ARANDELA ONDULADA	1		1			
21	676-45941-62-EL	PROPELLER (3X11-1/2"X11"-H) PROPELA (3X11-1/2"X11"-H)	1		1			UR UR
	676-45943-62-EL	PROPELLER (3X11-1/2"X12"-H) PROPELA (3X11-1/2"X12"-H)	1		1			UR UR
	676-45945-62-EL	PROPELLER (3X11-3/4"X10"-H) PROPELA (3X11-3/4"X10"-H)	1		1			UR UR
	676-45947-62-EL	PROPELLER (3X11-3/4"X8-3/4"-H) PROPELA (3X11-3/4"X8-3/4"-H)	1		1			UR UR
	676-45949-62-EL	PROPELLER (3X11-1/2"X13-1/2"-H) PROPELA (3X11-1/2"X13-1/2"-H)	1		1			UR UR

FIG. 24 LOWER CASING & DRIVE 4

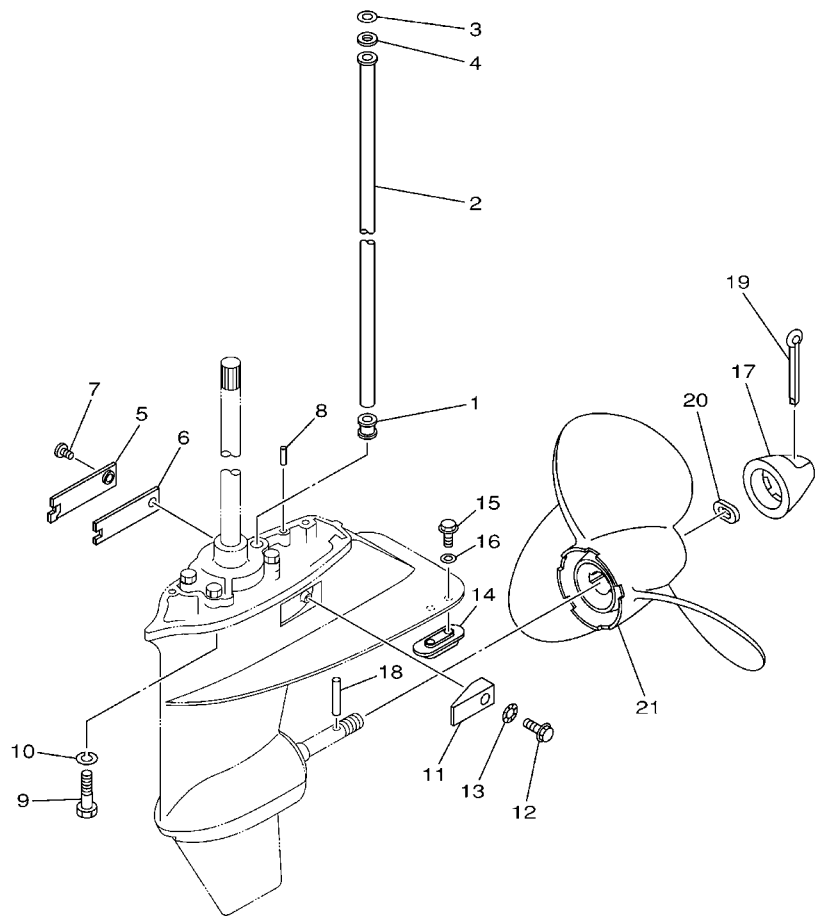
IMPULSOR E INFERIOR 4



REF. NO.	PART NO. CODIGO Nº	DESCRIPTION DESCRIPCION	E40M	40MH	E40W	40WH	40W	REMARKS OBSERVACIONES
21	676-45952-62-EL	PROPELLER (3X11-1/2"X13"-H) PROPELA (3X11-1/2"X13"-H)	1		1			UR UR
	676-45956-61-EL	PROPELLER (3X11-3/4"X7-1/2"-H) PROPELA (3X11-3/4"X7-1/2"-H)	1		1			UR UR

6J40200-1240

FIG. 25 FUEL TANK

DEPOSITO DE COMBUSTIBLE

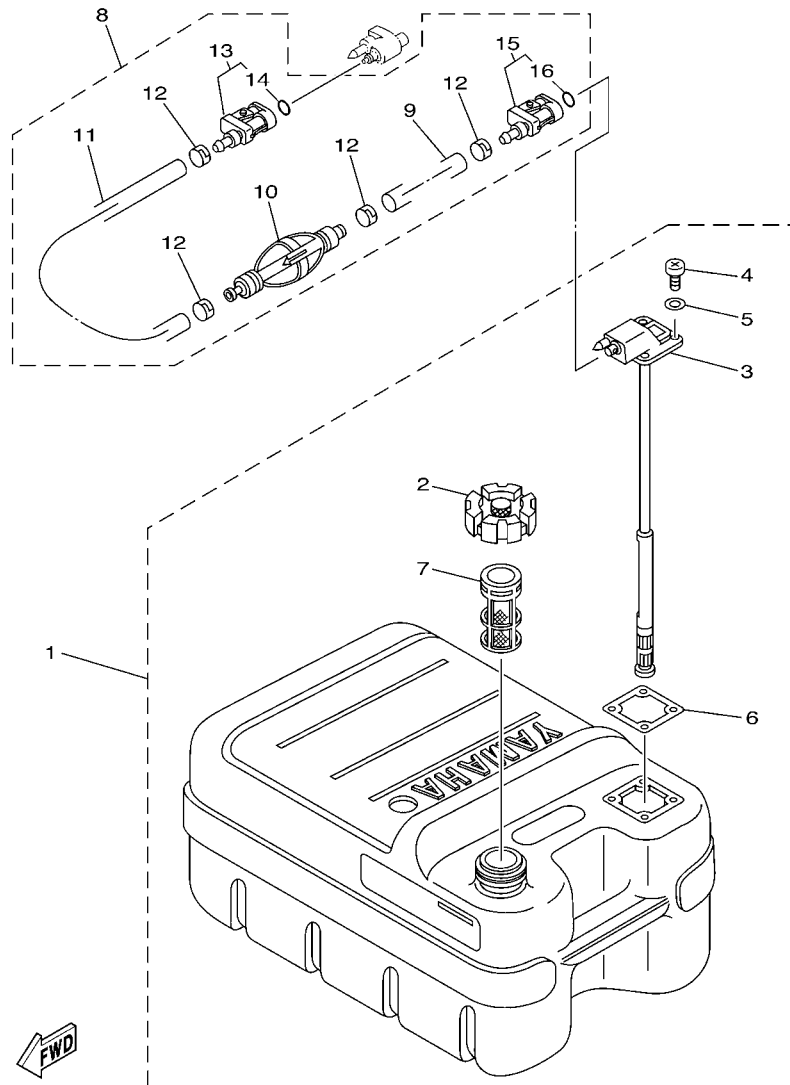

REF. NO.	PART NO. CODIGO Nº	DESCRIPTION DESCRIPCION	E40M	40MH	E40W	40WH	40W	REMARKS OBSERVACIONES
1	6YJ-24201-00	FUEL TANK ASSY (24L) TANQUE DEL COMBUSTIBLE (24L)	1	1	1	1	1	AP AP
	6YJ-24201-10	FUEL TANK ASSY (24L) TANQUE DEL COMBUSTIBLE (24L)		1		1	1	AP E40J-FOR CHN AP E40J-FOR CHN
2	6YJ-24610-01	.CAP ASSY .TAPA COMPLETA	1	1	1	1	1	
3	6YJ-24260-00	.FUEL METER ASSY .MEDIDOR DE COMBUSTIBLE COMPL.	1	1	1	1	1	
	6Y1-24260-12	.FUEL METER ASSY .MEDIDOR DE COMBUSTIBLE COMPL.		1		1	1	E40J-FOR CHN E40J-FOR CHN
4	90157-05M19	.SCREW, PAN HEAD .TORNILLO CABEZA CONICA PLANA	4	4	4	4	4	
5	6Y1-24329-00	.SEAL .SELLO	4	4	4	4	4	
6	6Y1-24268-00	.GASKET, FUEL METER .EMPAQ MEDIDOR DE COMBUSTIBLE	1	1	1	1	1	
7	6YJ-24167-00	.STRAINER .COLADOR	1	1	1	1	1	
8	61J-24306-04	FUEL PIPE COMP. 1 TUBO COMBUST. COMPL 1	1	1	1	1	1	AP AP
9	90445-11M06	.HOSE (L2050) .MANGUERA (L2050)	1	1	1	1	1	
10	61J-24360-00	.PRIMER PUMP ASSY .SOPORTE BOMBA	1	1	1	1	1	
11	90445-11M05	.HOSE (L850) .MANGUERA (L850)	1	1	1	1	1	
12	650-24351-01	.BAND 1 .ABRAZADERA 1	4	4	4	4	4	
13	6G1-24305-05	.FUEL PIPE JOINT COMP. 2 .CONECTOR MANGUERA COMBUST. 2	1	1	1	1	1	
14	93210-08287	..O-RING ..ANILLO O	1	1	1	1	1	
15	6Y1-24305-06	.FUEL PIPE JOINT COMP. 2 .CONECTOR MANGUERA COMBUST. 2	1	1	1	1	1	
16	93210-08287	..O-RING ..ANILLO O	1	1	1	1	1	

FIG. 26 STEERING GUIDE

DIRECCIONGUIAR

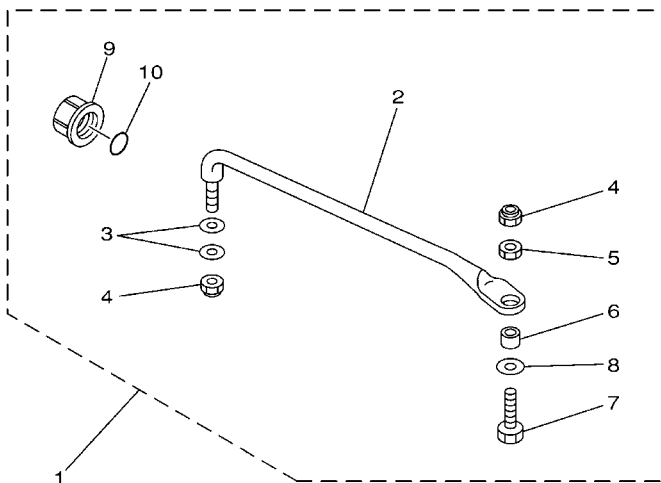

REF. NO.	PART NO. CODIGO Nº	DESCRIPTION DESCRIPCION	E40M	40MH	E40W	40WH	40W	REMARKS OBSERVACIONES
1	689-61350-02	STEERING GUIDE ATTACHMENT KIT ESTUCHE ADITAMENTO GUIA DE TIM					1	AP E40J-FOR CHN AP E40J-FOR CHN
2	689-61351-01	.ROD, STEERING LINK .VARILLA ESLABON DIRECCION					1	
3	90201-10M20	.WASHER, PLATE .ARANDELA PLANA					2	
4	90185-09M01	.NUT, SELF-LOCKING .TUERCA AUTOBLOCANTE					2	
5	90170-09M03	.NUT .TUERCA					1	
6	90387-10M42	.COLLAR .ESPACIADOR					1	
7	6E5-61355-00	.BOLT .TORNILLO					1	
8	90201-10M63	.WASHER, PLATE .ARANDELA PLANA					1	
9	6E5-43145-01	.CAP, CLAMP BRACKET .TAPA					1	
10	93210-16275	.O-RING .ANILLO O					1	

6J83100-2290

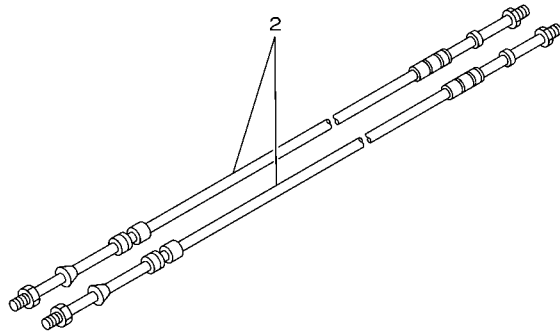
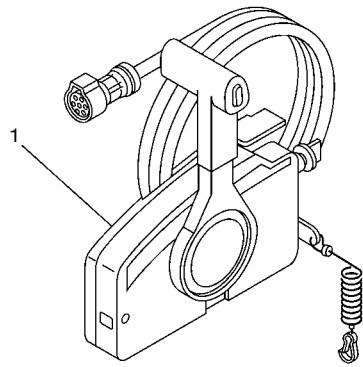

67M0100-8280

FIG. 27 REMOTE CONTROL BOX

CONTROL REMOTO COMPLETO

REF. NO.	PART NO. CODIGO Nº	DESCRIPTION DESCRIPCION	E40M	40MH	E40W	40WH	40W	REMARKS OBSERVACIONES
1	703-48230-15	REMOTE CONTROL ASSY (7P) CONTROL REMOTO COMPL. (7P)						1 AP WITHOUT PT/T SW. AP WITHOUT PT/T SW.
2	701-48320-20	CABLE, REMOTE CONTROL L=13F CABLE CONTROL REMOTO L=13F						2 UR UR
	701-48320-50	CABLE, REMOTE CONTROL L=15F CABLE CONTROL REMOTO L=15F						2 UR UR

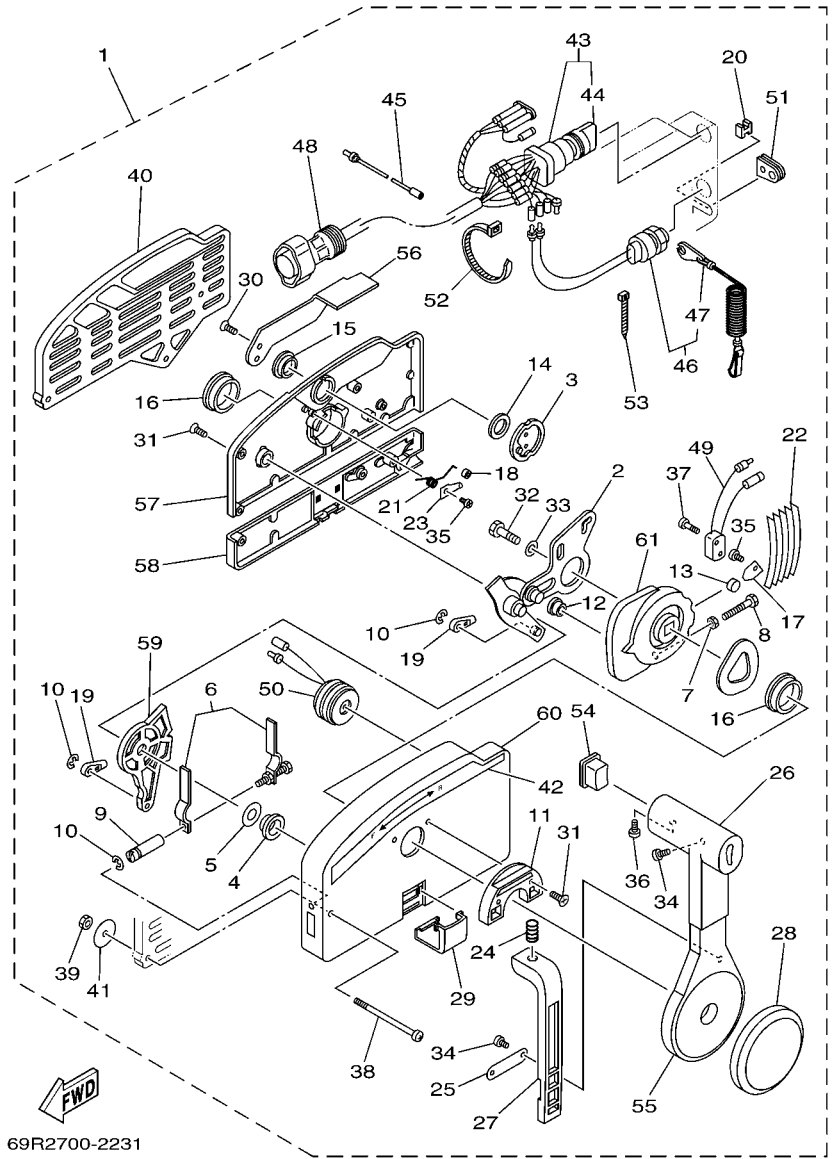

69R2700-2231

FIG. 28 REMOTE CONTROL ASSY CONTROL REMOTO COMPL

REF. NO.	PART NO. CODIGO Nº	DESCRIPTION DESCRIPCION	E40M	40MH	E40W	40WH	40W	REMARKS OBSERVACIONES
1	703-48230-15	REMOTE CONTROL ASSY (7P) CONTROL REMOTO COMPL. (7P)					1	AP WITHOUT PT/T SW. AP WITHOUT PT/T SW.
2	703-48261-11	.ARM, THROTTLE .BRAZO ACELERADOR					1	
3	703-48153-00	.SHAFT, FREE ACCEL. .EJE					1	
4	703-48235-00	.BUSHING .BUJE					1	
5	703-48268-00	.SPACER .ESPACIADOR 3					1	
6	703-48264-00	.FRICTION, THROTTLE .FRICCION DE ACELERADOR					1	
7	95380-05600	.NUT .TUERCA					1	
8	97380-05025	.BOLT .TORNILLO HEXAGONAL					1	
9	703-48265-00	.SHAFT, FRICTION .EJE FRICCION					1	
10	93430-06024	.CIRCLIP .SEGURO					3	
11	703-48245-00	.PLATE, LOCK .PLACA CERRADURA					1	
12	703-48252-00	.ROLLER, CAM .RODILLO LEVA					1	
13	701-48248-00	.ROLLER, FREE ACCEL. .RODILLO ACELERADOR LIBRE					1	
14	703-48198-00	.WASHER, WAVE .RONDANA ONDULADA 3					1	
15	703-48243-00	.BUSHING .BUJE 3					1	
16	703-48236-00	.BUSHING 1 .BUJE					2	
17	703-48189-00	.RETAINER .RETENEDOR					1	
18	703-48234-00	.ROLLER, DETENT .RODILLO					1	
19	703-48345-01	.CABLE END, REMOTE CONTROL 2 .TERMINAL CABLE DE CONTROL REM					2	
20	703-48358-00	.ANCHOR, CABLE .ABRAZADERA CABLE					1	
21	703-48244-00	.SPRING, FREE ACCEL. .RESORTE ACELERADOR LIBRE					1	
22	703-48238-00	.SPRING, DETENT .RESORTE					5	
23	703-48246-00	.SPACER .ESPACIADOR					1	
24	703-48227-00	.SPRING, NEUTRAL LOCK .RESORTE DE SEGURO					1	
25	703-48226-00	.PLATE, STOPPER .PLACA RETEN					1	
26	703-48222-00	.GRIP, CONTROL LEVER .MANGO DE PALANCA CONTROL					1	SINGLE SINGLE
27	703-48223-00	.LOCK, NEUTRAL .CERRADURA NEUTRO					1	

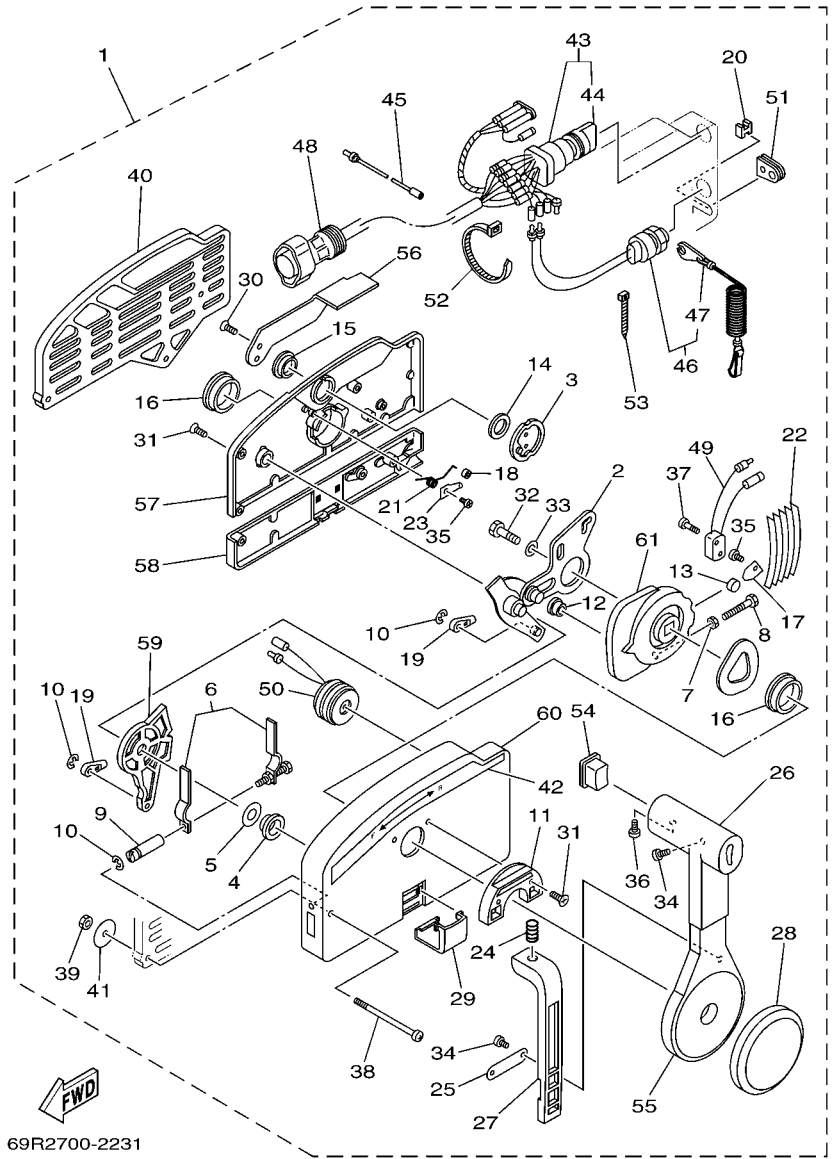

FIG. 28 REMOTE CONTROL ASSY CONTROL REMOTO COMPL

REF. NO.	PART NO. CODIGO Nº	DESCRIPTION DESCRIPCION	E40M	40MH	E40W	40WH	40W	REMARKS OBSERVACIONES
28	703-48225-00	.COVER .CUBIERTA					1	
29	703-48219-00	.COVER, LEAD .CUBIERTA					1	
30	703-48281-00	.SCREW .TORNILLO 1					2	
31	703-48282-00	.SCREW .TORNILLO 2					7	
32	97380-08030	.BOLT .TORNILLO HEXAGONAL					1	
33	92990-08600	.WASHER, PLATE .ARANDELA PLANA					1	
34	98580-04010	.SCREW, PAN HEAD .TORNILLO DE CABEZA CRUZADA					3	
35	98580-04006	.SCREW, PAN HEAD .TORNILLO DE CABEZA CRUZADA					2	
36	98580-05010	.SCREW, PAN HEAD .TORNILLO DE CABEZA CRUZADA					1	
37	98580-03015	.SCREW, PAN HEAD .TORNILLO DE CABEZA CRUZADA					2	
38	703-48291-10	.SCREW (M6) .TORNILLO (M6)					3	
39	95380-06600	.NUT, HEXAGON .TUERCA					3	
40	703-48293-10	.SPACER, REMOTE CONTROL .ESPACIADOR					1	SINGLE SINGLE
41	701-48287-00	.WASHER .ARANDELA					3	
42	703-48215-00	.GRAPHIC .CALCOMANIA 1					1	
43	703-82510-33	.MAIN SWITCH ASSY .CONJUNTO DE LLAVE IGNICION					1	
44	703-82577-00	.CAP, KEY .TAPA					1	
45	703-82531-00	.WIRE, LEAD (L70) .CABLE CONDUCTOR (L70)					1	
46	688-82575-01	.ENGINE STOP SWITCH ASSY .INTERRUPTOR DE PARADA COMPL					1	
47	682-82556-00	.LANYARD, STOP SWITCH .RETENER					1	
48	688-82586-21	.EXTENSION, WIRE HARNESS (4.9M) .EXTENSION, ARNES DE CABLES (4					1	(7P) (7P)
49	703-82540-00	.NEUTRAL SWITCH ASSY .INTERRUPTOR NEUTRAL COMPL					1	
50	703-83383-02	.BUZZER .ZUMBADOR					1	
51	703-48284-00	.GROMMET .TAPON 1					1	
52	703-82591-00	.BAND .BANDA					1	
53	703-82592-00	.BAND .BANDA					1	
54	703-48224-00	.COVER, CONTROL LEVER .CUBIERTA DE PALANCA CONTROL					1	WITHOUT PT/T SW. WITHOUT PT/T SW.

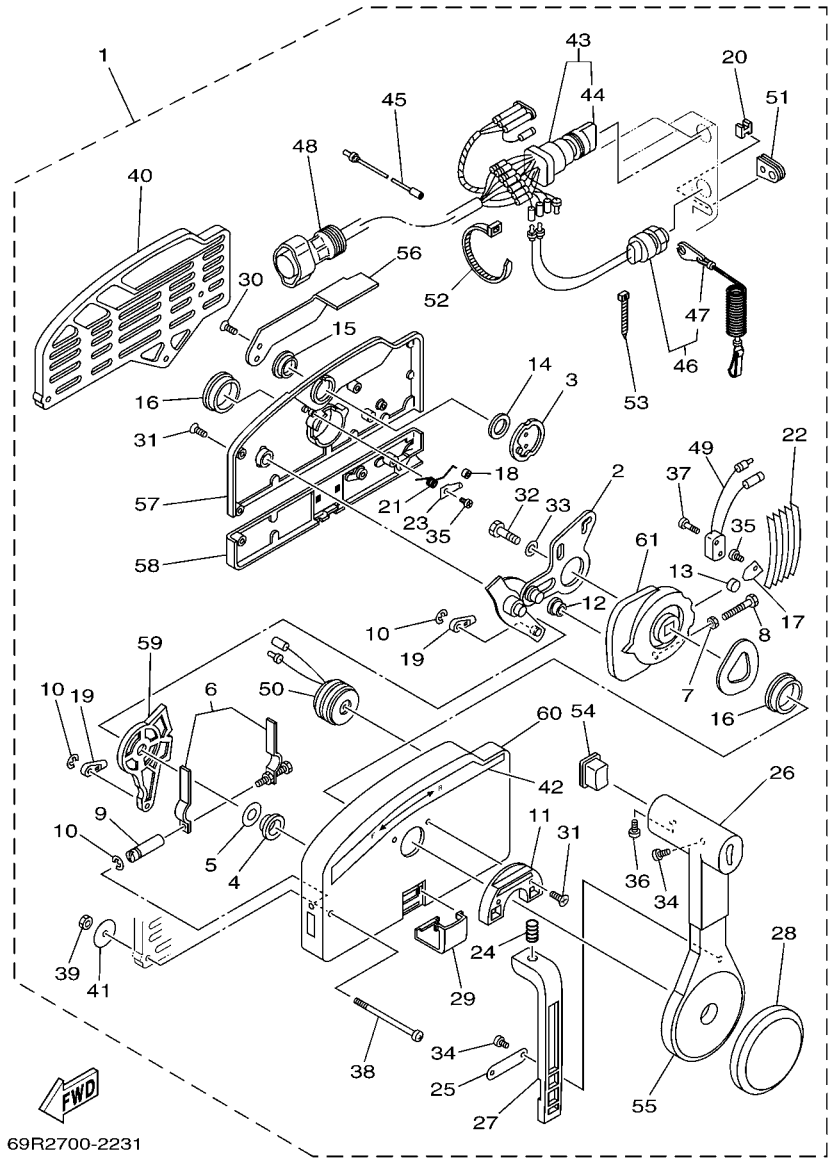

FIG. 28 REMOTE CONTROL ASSY CONTROL REMOTO COMPL

REF. NO.	PART NO. CODIGO Nº	DESCRIPTION DESCRIPCION	E40M	40MH	E40W	40WH	40W	REMARKS OBSERVACIONES
55	703-48221-00	.LEVER, CONTROL .PALANCA CONTROL					1	
56	703-48152-00	.KNOB, FREE ACCEL. .PERILLA					1	
57	703-48212-00	.BACK PLATE 1 .PLACA TRASERA 1					1	
58	703-48213-00	.BACK PLATE 2 .PLACA TRASERA 2					1	
59	703-48271-00	.ARM, SHIFT .BRAZO CAMBIADOR					1	
60	703-48211-01	.HOUSING,1 .CAJA					1	
61	703-48232-00	.GEAR .ENGRANAJE 1					1	

FIG. 29 REPAIR KIT 1

ESTUCHE REPARATION 1

REF. NO.	PART NO. CODIGO Nº	DESCRIPTION DESCRIPCION	E40M	40MH	E40W	40WH	40W	REMARKS OBSERVACIONES
1	6F6-W0001-02	POWER HEAD GASKET KIT JUEGO DE EMPAQUE	1	1	1	1	1	
2	93102-35M18	.OIL SEAL .SELLO ACEITE	1	1	1	1	1	
3	93210-75M51	.O-RING .ANILLO O	1	1	1	1	1	
4	6F5-13646-A2	.GASKET, MANIFOLD 2 .EMPAQ. DE MULTIPLE 2	1	1	1	1	1	
5	6F5-13621-A1	.GASKET, VALVE SEAT .JUNTA, DE VALV.DE EMPAQUE	2	2	2	2	2	
6	6F5-13645-A1	.GASKET, MANIFOLD 1 .EMPAQUE	1	1	1	1	1	
7	6F5-14198-A1	.GASKET .EMPAQUE	1	1	1	1	1	
8	6F5-14384-00	.GASKET, FLOAT CHAMBER .EMPAQUE DE CAMARA DE BOIA	1	1	1	1	1	
9	6F5-11181-A1	.GASKET, CYLINDER HEAD 1 .JUNTA, DE CULATA 1	1	1	1	1	1	
10	6F6-11193-A1	.GASKET, HEAD COVER 1 .EMPAQUE	1	1	1	1	1	
11	6E9-12414-A1	.GASKET, COVER .EMPAQUE	1	1	1	1	1	
12	6F5-41112-A0	.GASKET, EXHAUST INNER COVER .EMPAQUE	1	1	1	1	1	
13	6F5-41114-A0	.GASKET, EXHAUST OUTER COVER .EMPAQUE	1	1	1	1	1	
14	93104-16M01	.OIL SEAL .SELLO ACEITE	1	1	1	1	1	
15	93101-30M33	.OIL SEAL .SELLO ACEITE	2	2	2	2	2	
16	93210-65M50	.O-RING .ANILLO O	1	1	1	1	1	
17	93210-22M02	.O-RING .ANILLO O	1	1	1	1	1	
18	6F5-45113-A0	.GASKET, UPPER CASING .EMPAQUE	1	1	1	1	1	
19	93210-32738	.O-RING .ANILLO O	1	1	1	1	1	
20	650-24431-A0	.GASKET, FUEL PUMP 1 .EMPAQUE BOMBA COMBUST 1	1	1	1	1	1	
21	6F6-W0093-00	CARBURETOR REPAIR KIT KIT REPARACION CARBURADOR	1	1	1	1	1	
22	6F5-14384-00	.GASKET, FLOAT CHAMBER .EMPAQUE DE CAMARA DE BOIA	1	1	1	1	1	
23	1J2-14398-00	.GASKET .EMPAQUE	2	2	2	2	2	
24	6F6-14385-00	.FLOAT .BOIA	1	1	1	1	1	
25	98980-04006	.SCREW, BIND .TORNILLO DE LIGAR	1	1	1	1	1	
26	6F5-14398-00	.GASKET .EMPAQUE	1	1	1	1	1	
27	6F5-14390-21	.NEEDLE VALVE ASSY .VALVULA DE AGUJA COMPLETA	1	1	1	1	1	

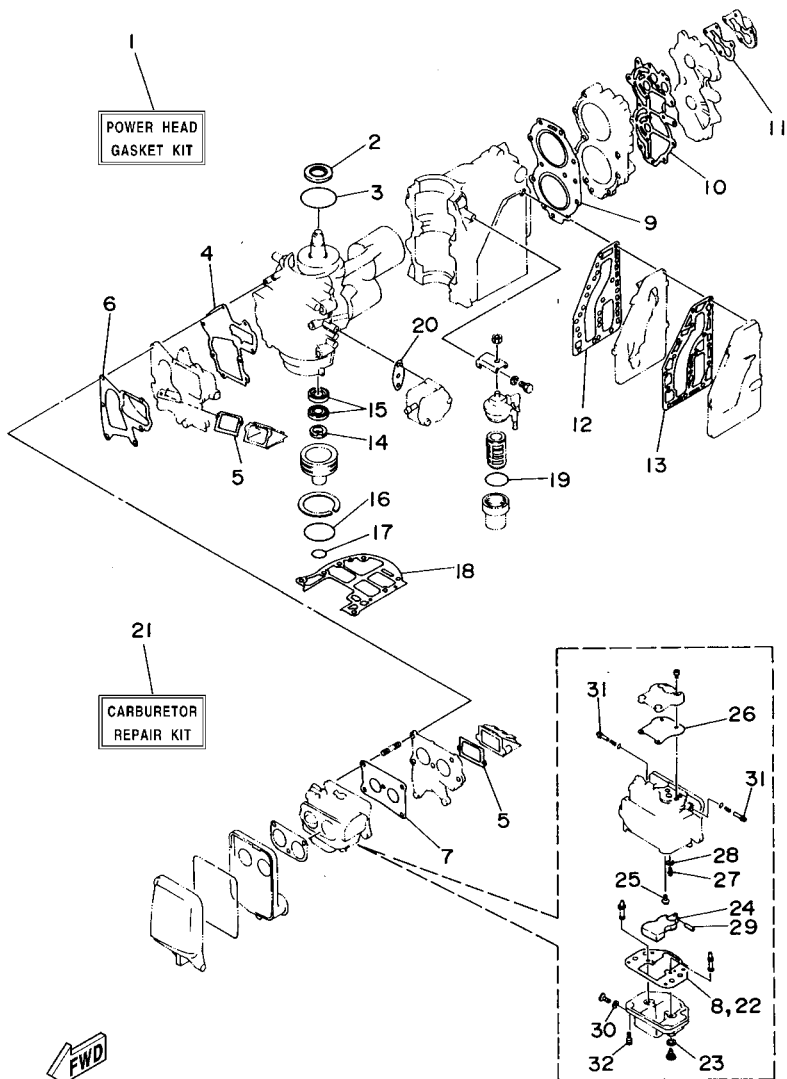

6J40200-4290

FIG. 30 REPAIR KIT 2

ESTUCHE REPARATION 2

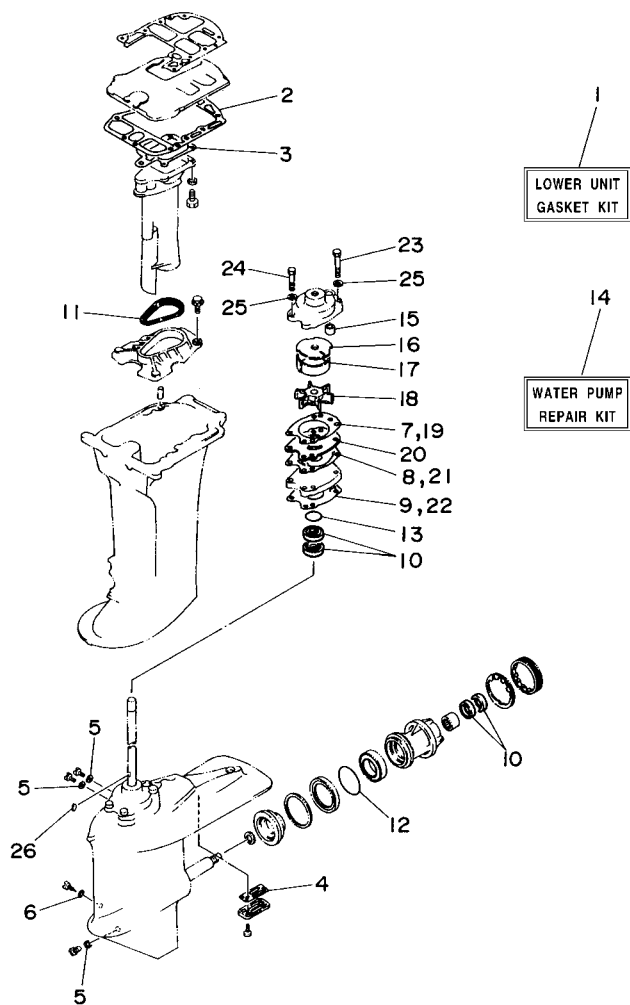

FWD
6J46200-F300

REF. NO.	PART NO. CODIGO N°	DESCRIPTION DESCRIPCION	E40M	40MH	E40W	40WH	40W	REMARKS OBSERVACIONES
1	6H9-W0001-22	LOWER UNIT GASKET KIT JUEGO DE JUNTA UNIDAD INFERIOR		1		1	1	E40J E40J
2	676-45114-A1	.GASKET, UPPER CASING .EMPAQUE		1		1	1	
3	676-41133-A1	.GASKET, EXHAUST MANIFOLD 1 .EMPAQUE ESCAPE MULTIPLE		1		1	1	
4	679-45315-A1	.PACKING, LOWER CASING .EMPAQUE		1		1	1	
5	90430-08020	.GASKET .JUNTA		3		3	3	
6	90430-06M03	.GASKET .JUNTA		1		1	1	
7	676-44315-A1	.GASKET, WATER PUMP .EMPAQUE		1		1	1	
8	676-44324-A1	.GASKET, CARTRIDGE .EMPAQUE		1		1	1	
9	679-44316-A1	.GASKET, WATER PUMP .EMPAQUE		1		1	1	
10	93101-22M00	.OIL SEAL .SELLO ACEITE		4		4	4	
11	676-45127-00	.SEAL .SELLO DE GOMA		1		1	1	
12	93210-66M98	.O-RING .ANILLO O		1		1	1	
13	93210-41042	.O-RING .ANILLO O		1		1	1	
14	6J4-W0078-00	WATER PUMP REPAIR KIT ESTUCHE REPARACION BOMBA AGUA		1		1	1	E40J E40J
15	663-44366-00	.DAMPER, WATER SEAL .GOMA DEL SELLO DE AGUA		1		1	1	
16	676-44321-40	.INNER PLATE, CARTRIDGE .PLACA INTERIOR CARTUCHO		1		1	1	
17	676-44322-40	.INSERT, CARTRIDGE .CARTUCHO		1		1	1	
18	6F5-44352-00	.IMPELLER .IMPULSOR		1		1	1	
19	676-44315-A1	.GASKET, WATER PUMP .EMPAQUE		1		1	1	
20	676-44323-40	.OUTER PLATE, CARTRIDGE .PLACA EXTERIOR DEL CARTUCHO		1		1	1	
21	676-44324-A1	.GASKET, CARTRIDGE .EMPAQUE		1		1	1	
22	679-44316-A1	.GASKET, WATER PUMP .EMPAQUE		1		1	1	
23	97095-08055	.BOLT .PERNO		2		2	2	
24	97095-08045	.BOLT .PERNO		2		2	2	
25	92995-08600	.WASHER .ARANDELA		4		4	4	
26	90280-04M00	.KEY, WOODRUFF .CUNA WOODRUFF		1		1	1	

FIG. 31 REPAIR KIT 3

ESTUCHE REPARATION 3

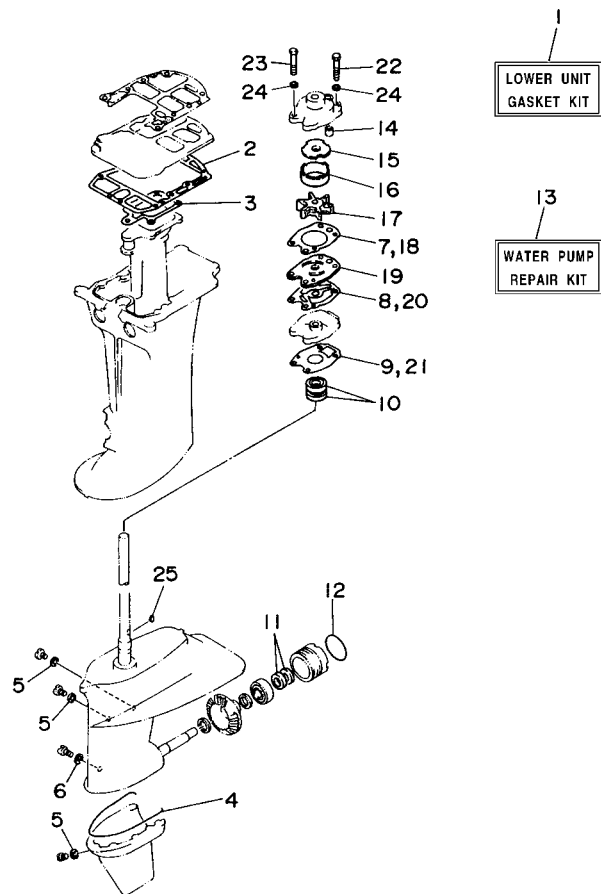

6J46200-F310

REF. NO.	PART NO. CODIGO Nº	DESCRIPTION DESCRIPCION	E40M	40MH	E40W	40WH	40W	REMARKS OBSERVACIONES
1	6F5-W0001-C0	LOWER UNIT GASKET KIT JUEGO DE JUNTA UNIDAD INFERIOR	1		1			E40G E40G
2	676-45114-A1	.GASKET, UPPER CASING .EMPAQUE	1		1			
3	676-41133-A1	.GASKET, EXHAUST MANIFOLD 1 .EMPAQUE ESCAPE MULTIPLE	1		1			
4	676-45314-00	.SEAL, LOWER CASING .SELLO DE FUNDA INFERIOR	1		1			
5	90430-08020	.GASKET .JUNTA	3		3			
6	90430-06M03	.GASKET .JUNTA	1		1			
7	676-44315-A1	.GASKET, WATER PUMP .EMPAQUE	1		1			
8	676-44324-A1	.GASKET, CARTRIDGE .EMPAQUE	1		1			
9	676-44316-A1	.GASKET, WATER PUMP .EMPAQUE	1		1			
10	93101-22M00	.OIL SEAL .SELLO ACEITE	2		2			
11	93101-20048	.OIL SEAL .SELLO ACEITE	2		2			
12	93210-57M00	.O-RING .ANILLO O	1		1			
13	6F6-W0078-00	WATER PUMP REPAIR KIT ESTUCHE REPARACION BOMBA AGUA	1		1			E40G E40G
14	663-44366-00	.DAMPER, WATER SEAL .GOMA DEL SELLO DE AGUA	1		1			
15	676-44321-40	.INNER PLATE, CARTRIDGE .PLACA INTERIOR CARTUCHO	1		1			
16	676-44322-40	.INSERT, CARTRIDGE .CARTUCHO	1		1			
17	6F5-44352-00	.IMPELLER .IMPULSOR	1		1			
18	676-44315-A1	.GASKET, WATER PUMP .EMPAQUE	1		1			
19	676-44323-40	.OUTER PLATE, CARTRIDGE .PLACA EXTERIOR DEL CARTUCHO	1		1			
20	676-44324-A1	.GASKET, CARTRIDGE .EMPAQUE	1		1			
21	676-44316-A1	.GASKET, WATER PUMP .EMPAQUE	1		1			
22	97095-08055	.BOLT .PERNO	2		2			
23	97095-08045	.BOLT .PERNO	2		2			
24	92995-08600	.WASHER .ARANDELA	4		4			
25	90280-04M00	.KEY, WOODRUFF .CUNA WOODRUFF	1		1			

NUMERICAL INDEX
INDICE NUMERICO

PART NO. CODIGO N°	REF. NO.	PART NO. CODIGO N°	REF. NO.	PART NO. CODIGO N°	REF. NO.	PART NO. CODIGO N°	REF. NO.	PART NO. CODIGO N°	REF. NO.	PART NO. CODIGO N°	REF. NO.
6F6-11111-00-1S	2 - 22	6F6-14301-06	5 - 1	6F5-15739-00	7 - 20	61N-24563-00	6 - 7	676-42511-03-4D	17 - 26	676-43615-00	18 - 19
6F5-11119-00	2 - 20	650-14321-01	5 - 18	6F5-15741-01	7 - 4	648-24566-02	6 - 10	676-42521-00-94	17 - 32	676-43616-00	18 - 16
6F5-11181-A1	2 - 23	6F5-14323-01	5 - 23	6F5-15746-00	7 - 39	6YJ-24610-01	25 - 2	648-42528-00	17 - 15	6F5-43627-80	18 - 5
	29 - 9		29 - 31	6F5-15747-00	7 - 38	6F5-26311-00	14 - 21	676-42591-00	17 - 73	6F5-43628-80	18 - 6
6F6-11191-00-1S	2 - 25	6A0-14325-00	6 - 25	656-15748-00	7 - 43	676-26326-00	13 - 14	6F6-42610-10-4D	1 - 1	6F5-43630-80	18 - 12
6F6-11193-A1	2 - 26	647-14334-00	5 - 19	6F5-15752-00	7 - 16	676-26391-00	14 - 22	6J4-42610-J0-4D	1 - 1	676-43631-00	18 - 13
	29 - 10	6F5-14334-01	5 - 24	6F5-15753-00	7 - 17	676-26392-00	14 - 23	6F6-42612-00	1 - 16	676-43643-00	18 - 30
676-11325-00	2 - 18	6F6-14341-00	5 - 4	6F5-15754-00	7 - 9	626-28193-01-94	6 - 34	6F6-42613-00-4D	1 - 7	6F5-44111-00	15 - 11
650-11370-01	2 - 4	647-14342-45	5 - 12	689-15755-01	7 - 14	6F5-41111-01-1S	2 - 41	6F5-42613-01-4D	1 - 7	6F5-44111-50	16 - 1
	4 - 5	677-14343-75	5 - 6	6A0-15758-01-94	7 - 27	6F5-41112-A0	2 - 40	6F5-42615-00	1 - 11	6F5-44121-00	15 - 17
6F6-11370-01	4 - 4	6F6-14381-00	5 - 3	6A0-15761-00	1 - 2		29 - 12	6E9-42651-01	1 - 3	6F5-44125-00	15 - 12
6F6-11400-02	3 - 1	6F6-14383-00	5 - 13	6A0-15762-01	7 - 30	6F5-41113-01-1S	2 - 38	6F5-42652-01	1 - 5	676-44143-00	15 - 26
6F5-11412-11	3 - 2	6F5-14383-10	5 - 21	6F5-15764-00	7 - 15	6F5-41114-A0	2 - 42	69P-42677-H0	1 - 14	648-44146-00	15 - 27
6F5-11422-11	3 - 3	6F5-14384-00	5 - 2	6F5-15768-00	7 - 19		29 - 13	6F6-42678-00	1 - 13	650-44147-00	21 - 64
6F5-11432-11	3 - 4		29 - 8	6F5-15770-00	7 - 40	6F5-41116-00-5B	19 - 6	6J4-42678-H0	1 - 13		23 - 63
6F5-11442-11	3 - 5	6F6-14385-00	5 - 7	6F5-15771-00-94	7 - 32		20 - 6	6F6-42711-03-4D	13 - 1	676-44150-00	23 - 60
6F5-11515-00	3 - 9		29 - 24	6F5-15772-00-94	7 - 35	676-41131-01-5B	19 - 13	6F5-42715-00	15 - 22	679-44150-00	21 - 60
6F5-11610-00	3 - 16	6E5-14386-01	5 - 9	6F5-15773-00	7 - 41		20 - 13	6F5-42716-00	13 - 11	676-44150-10	23 - 60
6F5-11610-10	3 - 16		29 - 29	6F5-15774-00	7 - 42	676-41133-A1	19 - 14	6F5-42724-00	13 - 12	679-44150-10	21 - 60
6F5-11610-20	3 - 16	6F5-14390-21	5 - 10	6F5-15779-02	7 - 21		20 - 14	676-42724-40	13 - 14	676-44150-20	23 - 60
6F6-11631-00-95	3 - 15		29 - 27	6A0-15789-00	7 - 31		30 - 3	6F5-42724-40	13 - 12	6A0-44150-20	21 - 60
6F5-11633-00	3 - 17	647-14395-60	4 - 24	6F5-15791-00	7 - 18		31 - 3	6F5-42725-50	16 - 10	679-44152-00	21 - 61
663-11634-00	3 - 18	5Y1-14397-00	5 - 25	6YJ-24167-00	25 - 7	6F5-41137-02-94	19 - 8	676-42726-00	13 - 22	6F5-44167-00	15 - 23
6F6-11635-00	3 - 15	1J2-14398-00	5 - 5	6YJ-24201-00	25 - 1		20 - 8	6F5-42727-00	13 - 13	6F5-44173-00	15 - 21
6F6-11636-00	3 - 15		29 - 23	6YJ-24201-10	25 - 1	6F5-41141-00	19 - 9	6F5-42738-01-94	13 - 8	676-44311-00	21 - 18
6F5-11651-00	3 - 11	6F5-14398-00	5 - 14	6YJ-24260-00	25 - 3		20 - 9	6F5-42741-11	13 - 24		23 - 23
6F5-11681-00	3 - 12		29 - 26	6Y1-24260-12	25 - 3	6F5-41211-00	15 - 9	664-42791-00	13 - 28	676-44315-A1	21 - 21
6F5-12411-03	2 - 33	6F6-14398-00	5 - 22	6Y1-24268-00	25 - 6	6E9-41237-00	15 - 10	664-42791-10	13 - 28		23 - 26
6E5-12412-00	2 - 34		29 - 30	6G1-24304-02	6 - 1	6F5-41237-00	16 - 4	6F5-42815-01-4D	13 - 3		30 - 7
6E9-12413-00-1S	2 - 35	6F5-14417-00	4 - 28	6G1-24305-05	25 - 13	6F5-41252-00	4 - 39	6F5-42816-00	13 - 5		31 - 7
6E9-12414-A1	2 - 36	6F5-14418-00	4 - 29	6Y1-24305-06	25 - 15	6F6-41256-00	4 - 42	676-43111-04-4D	17 - 1	676-44316-A1	23 - 29
	29 - 11	6F5-14476-00	4 - 32	61J-24306-04	25 - 8	661-41262-02	4 - 43	676-43112-04-4D	17 - 7		31 - 9
663-12416-00	2 - 28	6F5-14483-00	4 - 38	6Y1-24329-00	25 - 5		7 - 50	6J8-43113-01	17 - 23	679-44316-A1	21 - 25
677-13437-0B	1 - 15	624-14485-00	2 - 3	650-24351-01	25 - 12	682-41271-00	4 - 40	6F5-43114-00	17 - 2		30 - 9
6F6-13610-00	4 - 1		4 - 22	61J-24360-00	25 - 10	689-41273-00	4 - 41	6F5-43116-00	17 - 3	676-44321-40	21 - 20
6F5-13621-A1	4 - 9	6F6-14488-00	7 - 51	650-24378-00	2 - 39	6F5-41283-00	15 - 3	663-43118-01-4D	17 - 4		23 - 24
	29 - 5	6F6-14488-10	7 - 51	692-24410-00	6 - 15	6F5-41638-00	15 - 2	6J8-43131-01	17 - 20		30 - 16
6F6-13641-00-1S	4 - 3	6F5-14497-00	15 - 1	663-24411-00	6 - 20	6F5-41662-00	15 - 14	676-43132-00	18 - 2		31 - 15
6F6-13643-01-1S	4 - 17	6F6-15100-02-1S	2 - 2	692-24411-00	6 - 17	676-42111-03-4D	14 - 2	6E5-43145-01	26 - 9	676-44322-40	21 - 19
6F5-13645-A1	4 - 21	6F5-15396-01-5B	2 - 8	6A0-24412-02	6 - 26	676-42115-00	14 - 11	6G5-43145-01	17 - 25		23 - 25
	29 - 6	6F5-15711-02	7 - 2	6A0-24413-00	6 - 16	664-42119-00	14 - 3	676-43160-02	18 - 26		30 - 17
6F5-13646-A2	4 - 6	6F5-15713-00	7 - 5	6A0-24421-01	6 - 24	6F5-42125-00	14 - 34	676-43165-00	18 - 27		31 - 16
	29 - 4	6F5-15714-03	7 - 3	650-24431-A0	6 - 27	6F5-42126-00	14 - 33	676-43191-00	18 - 8	676-44323-40	21 - 26
367-14195-00	5 - 11	6F5-15715-00	7 - 6		29 - 20	6F6-42137-10	14 - 5	676-43311-10-4D	17 - 12		23 - 30
	29 - 28	6F5-15716-01	7 - 8	648-24434-01	6 - 18	676-42151-00-94	14 - 17	663-43318-00	18 - 17		30 - 20
6F5-14198-A1	4 - 25	6F5-15723-01	7 - 22	648-24435-02	6 - 21	650-42152-00-94	14 - 15	676-43373-00	17 - 17		31 - 19
	29 - 7	6F5-15726-01	7 - 11	61N-24521-00	6 - 8	676-42159-00	14 - 12	676-43613-00	18 - 20	676-44324-A1	21 - 27
6J4-14301-05	5 - 1	6F5-15734-01	7 - 7	61N-24560-00	6 - 6	6F6-42177-A0	14 - 4	676-43614-00	18 - 18		23 - 31

NUMERICAL INDEX
INDICE NUMERICO

PART NO. CODIGO N°	REF. NO.	PART NO. CODIGO N°	REF. NO.	PART NO. CODIGO N°	REF. NO.	PART NO. CODIGO N°	REF. NO.	PART NO. CODIGO N°	REF. NO.	PART NO. CODIGO N°	REF. NO.
676-44324-A1	30 - 8	676-45127-00	30 - 11	6A0-45501-20	21 - 36	663-45587-40	21 - 9	703-48219-00	28 - 29	689-81812-11	12 - 14
	31 - 8	676-45151-00-4D	19 - 25	676-45533-00	23 - 5	663-45587-50	21 - 9	703-48221-00	28 - 55	689-81813-10	12 - 15
679-44341-00-94	21 - 28		20 - 23	676-45536-00	23 - 7	663-45587-60	21 - 9	703-48222-00	28 - 26	6J4-81820-01	12 - 24
676-44341-01-94	23 - 32	676-45151-10-4D	19 - 25	679-45536-00	21 - 8	6F6-45611-00	23 - 46	703-48223-00	28 - 27	689-81820-11	12 - 16
6F5-44352-00	21 - 23		20 - 23	6H9-45551-00	21 - 37	679-45611-01	21 - 41	703-48224-00	28 - 54	689-81826-10	12 - 17
	23 - 27	676-45211-20-4D	20 - 18	6F5-45551-01	23 - 40	6F6-45614-00	24 - 18	703-48225-00	28 - 28	6F5-81830-11	12 - 6
	30 - 18	6A0-45211-20-4D	19 - 20	663-45552-00	21 - 38	676-45616-01	24 - 17	703-48226-00	28 - 25	689-81831-00	12 - 7
	31 - 17	6F5-45214-00	24 - 5	679-45560-00	21 - 40	663-45631-01	21 - 44	703-48227-00	28 - 24	689-81840-11	12 - 12
676-44361-00	22 - 2	688-45214-02	22 - 11	6F5-45560-01	23 - 43		23 - 49	703-48230-15	27 - 1	6F5-81842-41	12 - 1
	24 - 2	676-45215-01	23 - 15	676-45567-00	23 - 44	663-45633-00	21 - 46		28 - 1	689-81847-11	12 - 8
676-44361-10	22 - 2	688-45215-02	22 - 12	663-45567-01	21 - 11		23 - 51	703-48232-00	28 - 61	689-81850-12	12 - 10
	24 - 2	676-45251-00	2 - 15	663-45567-10	21 - 11	663-45634-00	21 - 43	703-48234-00	28 - 18	689-81857-11	12 - 4
676-44361-20	24 - 2	6F5-45251-02	24 - 11	676-45567-10	23 - 44		23 - 48	703-48235-00	28 - 4	6G1-81941-10	12 - 20
6A0-44361-20	22 - 2	6E0-45251-12	24 - 14	663-45567-20	21 - 11	676-45635-00	21 - 42	703-48236-00	28 - 16	6F5-81945-00	12 - 22
6H9-44362-00	22 - 8	6F5-45252-00	24 - 6	676-45567-20	23 - 44		23 - 47	703-48238-00	28 - 22	6F5-81948-00	9 - 25
663-44366-00	21 - 22	6F5-45279-01	23 - 16	663-45567-30	21 - 11	663-45930-00-98	22 - 23	703-48243-00	28 - 15	6G1-81952-00	12 - 21
	23 - 38	6F6-45300-02-4D	23 - 1	676-45567-30	23 - 44	663-45941-01-EL	22 - 23	703-48244-00	28 - 21	6F5-81970-61	10 - 8
	30 - 15	6J4-45300-02-4D	21 - 1	663-45567-40	21 - 11	676-45941-62-EL	24 - 21	703-48245-00	28 - 11		11 - 8
	31 - 14	6F6-45300-12-4D	23 - 1	676-45567-40	23 - 44	69W-45943-00-EL	22 - 23	703-48246-00	28 - 23	6F5-82105-00	10 - 6
663-44367-00	22 - 1	6H9-45300-12-4D	21 - 1	663-45567-50	21 - 11	676-45943-62-EL	24 - 21	701-48248-00	28 - 13		11 - 6
	24 - 1	6J4-45300-12-4D	21 - 1	676-45567-50	23 - 44	69W-45945-00-EL	22 - 23	703-48252-00	28 - 12	6F5-82117-00	10 - 5
6E5-44391-00	13 - 2	6F6-45300-22-4D	23 - 1	663-45567-60	21 - 11	676-45945-62-EL	24 - 21	703-48261-11	28 - 2	61A-82119-00	9 - 28
676-44511-00-94	17 - 61	6J4-45300-22-4D	21 - 1	6F5-45570-00	23 - 54	69W-45947-00-EL	22 - 23	703-48264-00	28 - 6		10 - 21
676-44512-00-94	17 - 62	6F5-45311-02-4D	23 - 2	679-45571-00	21 - 49	676-45947-62-EL	24 - 21	703-48265-00	28 - 9		11 - 28
679-44514-00-94	17 - 52	6F5-45312-01-4D	23 - 3	663-45576-00	21 - 53	663-45949-01-EL	22 - 23	703-48268-00	28 - 5	703-82119-00	8 - 21
676-44518-00	17 - 58	676-45314-00	23 - 20	676-45577-00	23 - 55	676-45949-62-EL	24 - 21	703-48271-00	28 - 59	663-82151-00	10 - 14
676-44521-00	17 - 66		31 - 4	663-45577-01	21 - 52	69W-45952-00-EL	22 - 23	703-48281-00	28 - 30		11 - 12
676-44522-01	17 - 67	679-45315-A1	21 - 5	663-45577-10	21 - 52	663-45952-02-EL	22 - 23	703-48282-00	28 - 31	61N-82317-00	9 - 3
676-44533-00	17 - 57		30 - 4	676-45577-10	23 - 55	676-45952-62-EL	24 - 21	703-48284-00	28 - 51	6A0-82317-00	11 - 19
676-44551-01-4D	17 - 38	679-45318-00	20 - 19	663-45577-20	21 - 52	663-45954-01-EL	22 - 23	701-48287-00	28 - 41	62E-8231X-00	9 - 10
676-44552-01-4D	17 - 39	6A0-45318-00	19 - 18	676-45577-20	23 - 55	663-45956-01-EL	22 - 23	703-48291-10	28 - 38	62E-82371-11	9 - 9
676-44553-01-4D	17 - 40	650-45321-00	23 - 61	663-45577-30	21 - 52	676-45956-61-EL	24 - 21	703-48293-10	28 - 40	6F6-82509-00	10 - 15
679-44555-00-94	17 - 41	679-45321-02	21 - 4	676-45577-30	23 - 55	663-45958-01-EL	22 - 23	701-48320-20	27 - 2	6F5-82510-10	10 - 11
676-44575-00	17 - 51	679-45331-00-94	21 - 50	663-45577-40	21 - 52	663-45970-60-98	22 - 23	701-48320-50	27 - 2	703-82510-33	28 - 43
676-45111-03-4D	19 - 1	688-45341-10	21 - 15	676-45577-40	23 - 55	663-45972-60-98	22 - 23	6F5-48345-00	16 - 3	703-82531-00	28 - 45
	20 - 1		23 - 19	663-45577-50	21 - 52	663-45974-60-98	22 - 23	703-48345-01	28 - 19	6F5-82540-00	10 - 20
6H9-45111-11-4D	19 - 1	676-45361-01-94	23 - 56	676-45577-50	23 - 55	663-45976-00-98	22 - 23	703-48358-00	28 - 20	703-82540-00	28 - 49
676-45111-15-4D	20 - 1	679-45371-00	22 - 15	663-45577-60	21 - 52	663-45978-00-98	22 - 23	676-48511-01	16 - 5	682-82556-00	28 - 47
6F5-45113-A0	19 - 2	663-45375-00	22 - 10	676-45577-60	23 - 55	663-45987-02	22 - 18	6F5-48538-00	16 - 2		9 - 17
	20 - 2	6H9-45375-00	22 - 10	676-45577-70	23 - 55	670-45997-02	22 - 19	689-61350-02	26 - 1	688-82560-10	28 - 46
	29 - 18	6H9-45376-00	22 - 9	676-45587-00	23 - 41	703-48152-00	28 - 56	689-61351-01	26 - 2	6E9-82575-02	13 - 19
676-45114-A1	19 - 10	663-45376-00-94	22 - 9	663-45587-01	21 - 9	676-45987-02	22 - 18	6F5-81355-00	8 - 9	676-82577-00	10 - 12
	20 - 10	697-45384-00	21 - 58	663-45587-10	21 - 9	703-48153-00	28 - 3	6F5-81328-00	28 - 7	703-82577-00	28 - 44
	30 - 2	676-45501-00	23 - 39	676-45587-10	23 - 41	703-48189-00	28 - 17	689-81809-11	12 - 9	689-8257Y-00	13 - 21
	31 - 2	679-45501-00	21 - 36	663-45587-20	21 - 9	703-48198-00	28 - 14	6J4-81800-01	12 - 3	688-82586-21	28 - 48
663-45119-00	17 - 14	676-45501-10	23 - 39	676-45587-20	23 - 41	703-48211-01	28 - 60	689-81807-12	12 - 5	6F5-82588-00	9 - 24
676-45127-00	19 - 15	679-45501-10	21 - 36	663-45587-30	21 - 9	703-48212-00	28 - 57	689-81809-11	12 - 9		
	20 - 15	676-45501-20	23 - 39	676-45587-30	23 - 41	703-48213-00	28 - 58	689-81810-11	12 - 11		
						703-48215-00	28 - 42	689-81811-11	12 - 13		

NUMERICAL INDEX
INDICE NUMERICO

PART NO. CODIGO N°	REF. NO.	PART NO. CODIGO N°	REF. NO.	PART NO. CODIGO N°	REF. NO.	PART NO. CODIGO N°	REF. NO.	PART NO. CODIGO N°	REF. NO.	PART NO. CODIGO N°	REF. NO.
6J4-82590-10	11 - 11	90101-12M01	17 - 46	90201-09M00	17 - 55	90340-14036	2 - 30	90465-08M07	9 - 13	92990-06300	24 - 13
6F5-82590-20	9 - 18	90101-12M37	14 - 27	90201-10M02	14 - 8	90385-12M04	7 - 25	90465-11M10	9 - 11	92990-08100	17 - 10
6F5-82590-30	10 - 13	90105-06M01	19 - 7	90201-10M20	26 - 3	90386-08032	14 - 10	90465-11M52	17 - 68		19 - 23
703-82591-00	28 - 52		20 - 7	90201-10M63	26 - 8	90386-08M00	14 - 20	90467-06016	4 - 16	92990-08600	12 - 19
703-82592-00	28 - 53		23 - 22	90201-12426	17 - 71	90386-12089	14 - 26	90467-08004	2 - 45		28 - 33
703-83383-02	28 - 50	90105-06M21	24 - 12	90201-12537	14 - 30	90386-12M37	13 - 4		6 - 5	92990-10100	16 - 7
65L-83557-00	9 - 29	90105-08M10	7 - 23	90201-12M16	17 - 47	90386-22M15	17 - 21	90468-07179	8 - 22	92990-10600	16 - 8
6G1-83557-00	10 - 17	90105-08M35	9 - 26	90201-13M11	17 - 49	90386-44M03	17 - 36		11 - 24	92990-12200	14 - 28
	11 - 25	90105-08M50	12 - 18	90201-20417	3 - 20	90386-52M02	17 - 35	90480-09M21	13 - 15	92990-16200	22 - 20
6G5-83557-00	10 - 19	90105-08M51	12 - 25	90201-20MA8	23 - 53	90387-06035	13 - 16	90480-10155	11 - 16	92995-05600	14 - 25
	11 - 27	90109-06M12	17 - 6	90201-21M18	8 - 20	90387-06119	9 - 4	90480-17165	11 - 29	92995-06100	1 - 9
6N7-83557-00	9 - 27	90109-06M86	9 - 7	90201-22429	21 - 47		11 - 23	90480-17M08	10 - 22		19 - 12
6A1-83625-41	7 - 52	90116-06M17	4 - 10	90201-22M03	17 - 22	90387-06M29	7 - 49		11 - 30		20 - 12
6E0-83627-41	14 - 37	90116-08M00	17 - 8	90201-44M01	17 - 34		15 - 4	90480-18065	2 - 27	92995-06600	1 - 10
6F5-85515-10	8 - 8	90116-08M12	19 - 22	90202-06M00	18 - 10	90387-07M04	18 - 25	90480-25161	9 - 12		2 - 17
6F5-85520-10	8 - 4	90119-06121	1 - 17	90202-12060	22 - 3	90387-08M02	17 - 9	90501-07M33	15 - 25		4 - 26
6F6-85530-01	9 - 8	90119-06M11	13 - 27		24 - 3	90387-08M05	7 - 26	90501-10227	7 - 44		6 - 3
6F5-85533-10	8 - 5	90119-06M61	13 - 17	90202-12092	14 - 29	90387-08M12	12 - 2	90501-12M36	15 - 24		7 - 29
6F6-85540-01	9 - 6	90119-06M65	9 - 5	90202-12M01	18 - 3	90387-10M42	26 - 6	90501-14M02	2 - 29		8 - 17
6F5-85542-10	9 - 2	90119-06M73	13 - 6	90202-21100	17 - 48	90430-06M03	21 - 16	90501-14M05	18 - 11		9 - 15
6F6-85550-B0	8 - 1	90119-06MA3	2 - 31	90206-12052	13 - 7		23 - 13	90501-16M01	21 - 48		10 - 2
6F5-85550-G0	8 - 1	90119-06MA4	2 - 37	90206-12054	14 - 31		30 - 6		23 - 52		11 - 2
6F5-85560-B0	8 - 2	90119-08M10	7 - 24	90206-12M00	18 - 4		31 - 6	90501-18M00	17 - 16		13 - 26
6F5-85580-10	8 - 6	90119-08MA5	2 - 24	90206-16M03	24 - 20	90430-08020	21 - 13	90501-23215	14 - 9		14 - 14
6F5-85580-20	8 - 7	90119-10005	2 - 6	90209-27012	3 - 13		23 - 11	90502-10M04	18 - 29		15 - 6
6F5-85597-H0	8 - 14	90119-10028	2 - 7	90209-52M00	17 - 33		30 - 5	90506-30M00	18 - 23		21 - 63
6F5-85597-J0	8 - 13	90141-06M00	2 - 19	90214-48M03	21 - 57		31 - 5	90508-14M00	18 - 15	92995-08100	10 - 4
6J4-86111-00	11 - 13	90149-05M13	14 - 7	90240-05M09	15 - 18	90430-12072	22 - 4	91490-16010	14 - 36		11 - 4
6J4-86112-00	11 - 15	90149-06M00	21 - 17	90243-04007	17 - 5		24 - 4		15 - 19		17 - 28
6J4-86116-00	11 - 14		23 - 14	90249-07M01	18 - 21	90430-14115	2 - 32	91490-20012	18 - 24		19 - 5
682-86117-00	11 - 18	90152-05M09	22 - 13	90249-07M02	18 - 22	90445-07240	4 - 34	91490-30025	22 - 22		20 - 5
6F6-W0001-02	29 - 1	90152-06M06	24 - 7	90249-12M13	18 - 7	90445-07254	4 - 15	91490-40040	24 - 19		22 - 7
6H9-W0001-22	30 - 1	90157-05M19	25 - 4	90249-12M27	18 - 1	90445-07M24	4 - 35	91690-25016	15 - 13		24 - 10
6F5-W0001-C0	31 - 1	90159-04035	8 - 12	90250-06023	21 - 45	90445-09090	6 - 13	91690-30010	2 - 14	92995-08600	17 - 19
692-W0004-00	4 - 2	90159-04063	8 - 11		23 - 50	90445-09226	6 - 4		18 - 28		21 - 33
6F5-W0070-K0	1 - 12	90159-05040	8 - 10	90266-04M01	1 - 6	90445-09M37	2 - 44	91690-30025	14 - 16		23 - 35
6F6-W0078-00	31 - 13	90159-06M01	4 - 30	90266-04M04	1 - 4	90445-11M05	25 - 11	91690-40032	4 - 44		30 - 25
6J4-W0078-00	30 - 14	90170-07021	15 - 28	90269-02M09	14 - 6	90445-11M06	25 - 9	92903-06600	4 - 12		31 - 24
6F6-W0084-01-4D	14 - 1	90170-09M03	26 - 5	90269-04M00	18 - 31	90446-10M01	9 - 21		13 - 10	92995-10100	22 - 17
6F6-W0090-05-1S	2 - 1	90170-12138	21 - 39	90280-04M00	21 - 24	90446-10M02	9 - 1		15 - 16	92995-10600	17 - 70
6F6-W0093-00	29 - 21	90170-20137	8 - 19		23 - 28		10 - 7	92903-08600	7 - 34	93101-20048	23 - 58
6F5-W1571-03	7 - 1	90171-16011	22 - 21		30 - 26		11 - 7	92990-05100	4 - 8		31 - 11
676-W2810-01	6 - 33	90185-05002	22 - 14		31 - 25	90447-13011	13 - 23		5 - 16	93101-22M00	21 - 29
6J4-W4531-01-4D	21 - 2	90185-08057	17 - 56	90280-05015	8 - 18	90464-06006	10 - 18		6 - 23		23 - 6
6H9-W4531-12-4D	21 - 2	90185-09M01	26 - 4	90282-04010	21 - 59		11 - 26	92990-05600	5 - 17		30 - 10
90101-08001	2 - 21	90185-12058	14 - 32	90338-22007	21 - 3	90464-07008	6 - 32		10 - 10		31 - 10
90101-08M02	17 - 53	90185-22043	17 - 24	90340-08002	21 - 14	90464-07M06	9 - 16		11 - 10	93101-30M33	2 - 9
90101-10M58	17 - 69	90201-08M08	17 - 54		23 - 12	90464-16003	10 - 16	92990-06100	14 - 19		29 - 15

NUMERICAL INDEX
INDICE NUMERICO

PART NO. CODIGO N°	REF. NO.	PART NO. CODIGO N°	REF. NO.	PART NO. CODIGO N°	REF. NO.	PART NO. CODIGO N°	REF. NO.	PART NO. CODIGO N°	REF. NO.	PART NO. CODIGO N°	REF. NO.
93102-35M18	8 - 3	93606-12019	19 - 21	97095-06016	11 - 1	98580-03015	28 - 37				
	29 - 2		20 - 21		15 - 7	98580-04006	28 - 35				
93104-16M01	2 - 10		22 - 5	97095-06018	21 - 62	98580-04010	28 - 34				
	29 - 14		24 - 8	97095-06020	14 - 13	98580-05010	28 - 36				
93109-44M00	17 - 37	93606-25M00	19 - 3		19 - 16	98980-04006	5 - 8				
93210-03261	11 - 20		20 - 3		20 - 16		29 - 25				
93210-08287	25 - 14	93608-12063	2 - 5	97095-06025	1 - 18						
93210-16275	26 - 10		17 - 31		6 - 2						
93210-22M02	2 - 12	93700-06M03	17 - 13		9 - 14						
	29 - 17	94702-00040	2 - 46		11 - 21						
93210-32738	6 - 9	94702-00272	2 - 46		13 - 25						
	29 - 19	95303-08700	7 - 12		17 - 59						
93210-41042	21 - 30	95380-03600	6 - 19		19 - 11						
	30 - 13	95380-05600	28 - 7		20 - 11						
93210-57M00	23 - 59	95380-06600	4 - 27	97095-06030	7 - 47						
	31 - 12		13 - 18		15 - 5						
93210-65M50	2 - 11		14 - 18	97095-06040	6 - 28						
	29 - 16		17 - 60		8 - 16						
93210-66M98	21 - 54		28 - 39	97095-08016	10 - 3						
	30 - 12	95380-08600	6 - 11		11 - 3						
93210-75M51	8 - 15		17 - 11	97095-08040	19 - 4						
	29 - 3		19 - 24		20 - 4						
93306-00702	21 - 51	95380-10600	16 - 9	97095-08045	17 - 44						
93306-20401	23 - 57		17 - 72		21 - 34						
93306-306U2	3 - 8	95380-12800	17 - 50		23 - 36						
93306-307U0	3 - 6	95895-06016	24 - 15		30 - 24						
93310-727V7	3 - 14	97013-06014	6 - 12		31 - 23						
93315-217U0	23 - 4	97013-06025	4 - 13	97095-08050	17 - 63						
93315-32224	21 - 7		13 - 9	97095-08055	21 - 32						
93315-324U1	23 - 8		15 - 15		23 - 34						
93317-22204	21 - 55	97013-06065	4 - 11		30 - 23						
93332-00001	21 - 10	97013-08030	7 - 10		31 - 22						
93332-00003	21 - 12	97013-08035	7 - 33	97095-10030	22 - 16						
93332-000U0	23 - 45	97075-08025	17 - 18	97380-05025	28 - 8						
93332-000UE	3 - 7	97075-08030	17 - 27	97380-08030	28 - 32						
93342-624U0	23 - 9		22 - 6	97575-08480	20 - 22						
93390-000U0	23 - 10		24 - 9	97603-05117	5 - 20						
93410-16007	23 - 42	97075-08035	17 - 29		29 - 32						
93420-30042	20 - 20	97075-10040	16 - 6	97780-40520	15 - 20						
93420-36M01	19 - 19	97095-05010	14 - 24	97780-50716	4 - 31						
93430-06024	28 - 10		18 - 14	97780-60525	23 - 17						
93430-10M00	18 - 9	97095-06010	23 - 62	97880-05008	11 - 17						
93440-68M03	2 - 13	97095-06012	12 - 23	97880-05014	4 - 7						
	3 - 10	97095-06016	1 - 8	97880-05025	10 - 9						
93603-21111	3 - 19		2 - 16		11 - 9						
93604-08062	21 - 31		7 - 28	97880-06016	21 - 6						
	23 - 33		9 - 19	97890-05010	5 - 15						
93604-09068	23 - 21		10 - 1	98503-05028	6 - 22						