



**PARTS
CATALOGUE
CATALOGO
DE REPUESTOS**

E60J'08 (64S6)

E65A'08 (65S6)

E75B'08 (692F)

E60J
E65A/E75B
PARTS CATALOGUE
©2007 by Yamaha Motor Co., Ltd.
1st edition, September 2007
All rights reserved.
Any reprinting or unauthorized use
without the written permission of
Yamaha Motor Co., Ltd.
is expressly prohibited.
Printed in Japan.

E60J
E65A/E75B
CATALOGO DE REPUESTOS
©2007 por Yamaha Motor Co., Ltd.
1ª edición, septiembre 2007
Todos los derechos reservados.
Toda reproducción o uso no autorizado
sin el consentimiento escrito de
Yamaha Motor Co., Ltd.
quedan expresamente prohibidos
Impreso en Japón.

FOREWORD

This Parts Catalogue is related to the parts for the model(s) on the cover page. When you are ordering replacement parts, please refer to this Parts Catalogue and quote both part numbers and part names correctly.

1. Modifications or additions which have been made after the issue of the Parts Catalogue will be announced in the Parts News.
It is advisable that you make the necessary corrections to the Parts Catalogue according to the Parts News.

2. Abbreviations

The following abbreviations are used in this Parts Catalogue.

“UR” Use specified parts number.

“UN” Use as many as needed.

“AP” Alternate Parts

“LM” Locally Made (Parts need to be ordered locally)

“F#” Frame No. (Applicable machine No.)

“O/S” Over Size

3. The number of components for assembly

- Parts, which are to be supplied in an assembly, are listed with a dot (.) in front of the part name as shown below.
- The numeral appearing to the right of each component part indicates the quantity of parts for each assembly unit.

PART NO.	DESCRIPTION	Q'TY	REMARKS
2F5-83310-60	FRONT FLASHER LIGHT ASSY	2	
115-83311-60	.BULB (6V-18W)	1	

4. Applicable colours of graphics are represented in the “REMARKS” as shown below.

PART NO.	DESCRIPTION	Q'TY	REMARKS
2N4-24110-00-X5	FUEL TANK COMP.	2	MXR
3J1-24240-10	.GRAPHIC, FUEL TANK	1	FOR MXR

5. Note that the illustrations for reference in finding parts numbers are not to be used for assembling. When assembling, please use the applicable service manual.

6. The asterisk (*) before a reference number indicates modified items after the first edition.

7. Applicable Serial No.

Engine Serial No.

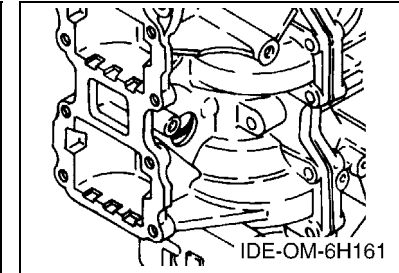
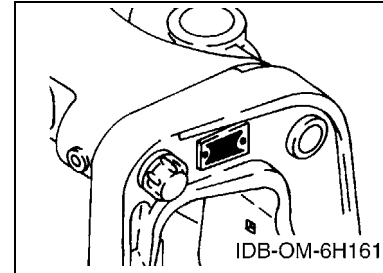

8. Applicable Engine Starting Serial No.

Model	Serial No.	Model	Serial No.
E60J	64S-1000387	E65A	65S-1000332
E75B	692-1028384		

9. Applicable Colour Code

Abbreviation	Colour Name	Colour Code
DBNM2	DARK BLUISH GRAY METALLIC 2	004D

10. Quantity Column Information

Column No.	Name Of Q'ty Column	Applicable Model
1	64S6	E60JMHD
2	65S6	E65AMHD
3	692F	E75BMHD

PROLOGO

Este catálogo de repuestos corresponde a las piezas para el o los modelos que figuran en la página de portada. Al formular el pedido de repuestos, se ruega citar este catálogo y especificar correctamente el número y el nombre de las piezas.

- Las modificaciones y agregados que se hayan realizado después de la edición de este Catálogo de Repuestos, serán anunciados en las Informaciones de Recambios. Es recomendable que se hagan las correcciones necesarias en el Catálogo de Repuestos de acuerdo con las Informaciones de Recambios.

2. Abreviaciones

En este. Catálogo de Repuestos se emplean las siguientes abreviaciones.

“UR” Usar el número de partes especificado

“UN” Usar la cantidad necesaria

“AP” Piezas sustitutivas

“LM” Fabricación local (Hay que pedir los repuestos en las cercanías)

“F#” N° de bastidor (N° aplicable a la máquina)

“O/S” Sobredimensionado

3. La cantidad de componentes para el montaje

- Los componentes, suministrados como conjunto, se describen con un punto (.) que precede al nombre del parte como se indica a continuación.
- La numeración que aparece a la derecha de cada descripción indica la cantidad de partes por cada unidad de conjunto.

CODIGO N°	DESCRIPCION	CANT.	OBSERVACIONES
2F5-83310-60	ENSAMBLAJE DE LA LUZ	2	
115-83311-60	.BOMBILLA (6V-18W)	1	

4. Los colores de los componentes se indican como sigue en la columna de “OBSERVACIONES”.

CODIGO N°	DESCRIPCION	CANT.	OBSERVACIONES
2N4-24110-00-X5	COMP. DEL TANQUE	2	MXR
3J1-24240-10	.GRAFICO, DEL TANQUE	1	PARA MXR

- Debe tenerse en cuenta que las ilustraciones sirven como guía para la búsqueda de los números de partes y no deben usarse para el montaje. Durante el montaje, se recomienda usar el manual de taller correspondiente.

- EL asterisco (*) antes del número de referencia indica los elementos modificados después de la primera edición.

7. Números de serie

N° de Serie del motor

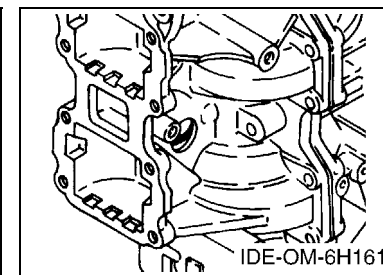
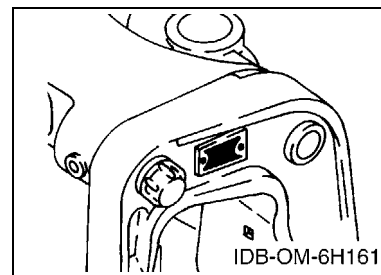

8. Números de serie del motor

Modelo	N° de serie	Modelo	N° de serie
E60J	64S-1000387	E65A	65S-1000332
E75B	692-1028384		

9. Códigos de color aplicables

Abreviatura	Nombre de color	Código de color
DBNM2	DARK BLUISH GRAY METALLIC 2	004D

10. Información para la columna de cantidades

Columna N°	Nombre de la columna de cantidades	Modelo aplicable
1	64S6	E60JMHD
2	65S6	E65AMHD
3	692F	E75BMHD

CONTENTS

TOP COWLING	1
CYLINDER & CRANKCASE	2
CRANKSHAFT & PISTON	4
INTAKE	6
CARBURETOR	8
FUEL	10
STARTER	12
GENERATOR	15
ELECTRICAL	16
BOTTOM COWLING	18
STEERING	20
CONTROL	23
BRACKET 1	26
BRACKET 2	28
BRACKET 3	29
UPPER CASING	31
LOWER CASING & DRIVE 1	33
LOWER CASING & DRIVE 2	37
LOWER CASING & DRIVE 3	41
FUEL TANK	43
OPTIONAL PARTS	44
REPAIR KIT 1	45
REPAIR KIT 2	47

INDEX

NUMERICAL INDEX	49
-----------------------	----

CONTENIDO

SOPORTE SUPERIOR	1
CYLINDRO & CARTER	2
CIGUENAL & PISTON	4
ADMISION	6
CARBURADOR	8
COMBUSTIBLE	10
ARRANQUE	12
GENERADOR	15
ELECTRICO	16
CUBIERTA INFERIOR	18
DIRECCION	20
CONTROL	23
SOPORTE 1	26
SOPORTE 2	28
SOPORTE 3	29
FUNDA SUPERIOR	31
IMPULSOR E INFERIOR 1	33
IMPULSOR E INFERIOR 2	37
IMPULSOR E INFERIOR 3	41
DEPOSITO DE COMBUSTIBLE	43
PARTES OPCIONALES	44
ESTUCHE REPARATION 1	45
ESTUCHE REPARATION 2	47

INDICE

INDICE NUMERICO	49
-----------------------	----

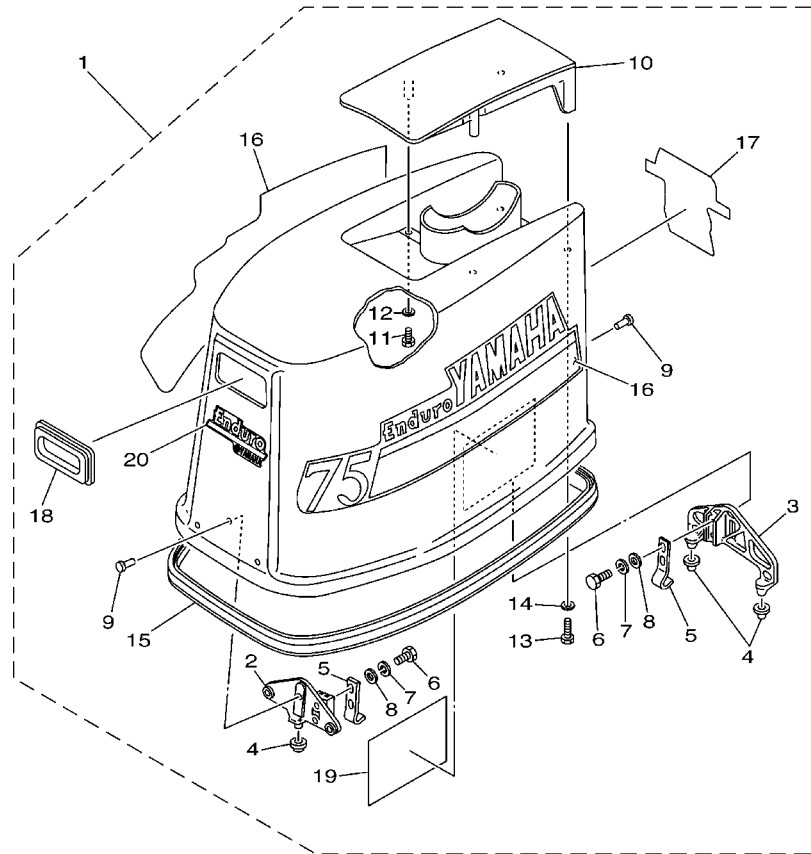

6923200-2010

FIG. 1 TOP COWLING

SOPORTE SUPERIOR

REF. NO.	PART NO. CODIGO Nº	DESCRIPTION DESCRIPCION	64S6	65S6	692F	REMARKS OBSERVACIONES
1	692-42610-F0-4D	TOP COWLING ASSY SOPORTE SUPERIOR COMPL.	1			
	692-42610-K0-4D	TOP COWLING ASSY SOPORTE SUPERIOR COMPL.		1		
	692-42610-L0-4D	TOP COWLING ASSY SOPORTE SUPERIOR COMPL.			1	
2	688-42647-00-94	.HOLDER, CLAMP BAND .MORDAZA DE ABRAZADERA	1	1	1	
3	692-42649-00-94	.HOLDER, CLAMP BAND .MORDAZA DE ABRAZADERA	1	1	1	
4	663-42662-00	.DAMPER .AMORTIGUADOR	3	3	3	
5	688-42652-10	.HOOK .GANCHO	2	2	2	
6	97095-06018	.BOLT .PERNO	2	2	2	
7	92995-06100	.WASHER, SPRING .ARANDELA	2	2	2	
8	92995-06600	.WASHER .ARANDELA	2	2	2	
9	90266-06009	.RIVET .REMACHE	6	6	6	
10	692-42613-01-4D	.MOLDING, AIR DUCT .MOLDURA CONDUCTO AIRE	1	1	1	
11	97095-06016	.BOLT .PERNO	2	2	2	
12	92995-06600	.WASHER .ARANDELA	2	2	2	
13	97095-06020	.BOLT .PERNO	2	2	2	
14	92995-06600	.WASHER .ARANDELA	2	2	2	
15	688-42615-00	.SEAL .SELLO	1	1	1	
16	692-W0070-J0	.GRAPHIC SET JUEGO DE EMBLEMA	1			
	692-W0070-W0	.GRAPHIC SET JUEGO DE EMBLEMA		1		
	692-W0070-H0	.GRAPHIC SET JUEGO DE EMBLEMA			1	
17	6K5-42678-H0	.GRAPHIC, REAR .CALCAMONIA TRASERA	1			
	692-42678-W0	.GRAPHIC, REAR .CALCAMONIA TRASERA		1		
	692-42678-H0	.GRAPHIC, REAR .CALCAMONIA TRASERA			1	
18	697-15761-01	.SEAL, RUBBER 1 .SELLO DE GOMA 1	1	1	1	
19	677-13437-0B	.MARKER .MARKER	1	1	1	
20	69P-42677-H0	.GRAPHIC, FRONT .CALCAMONIA FRONTAL	1	1	1	ENDURO ENDURO

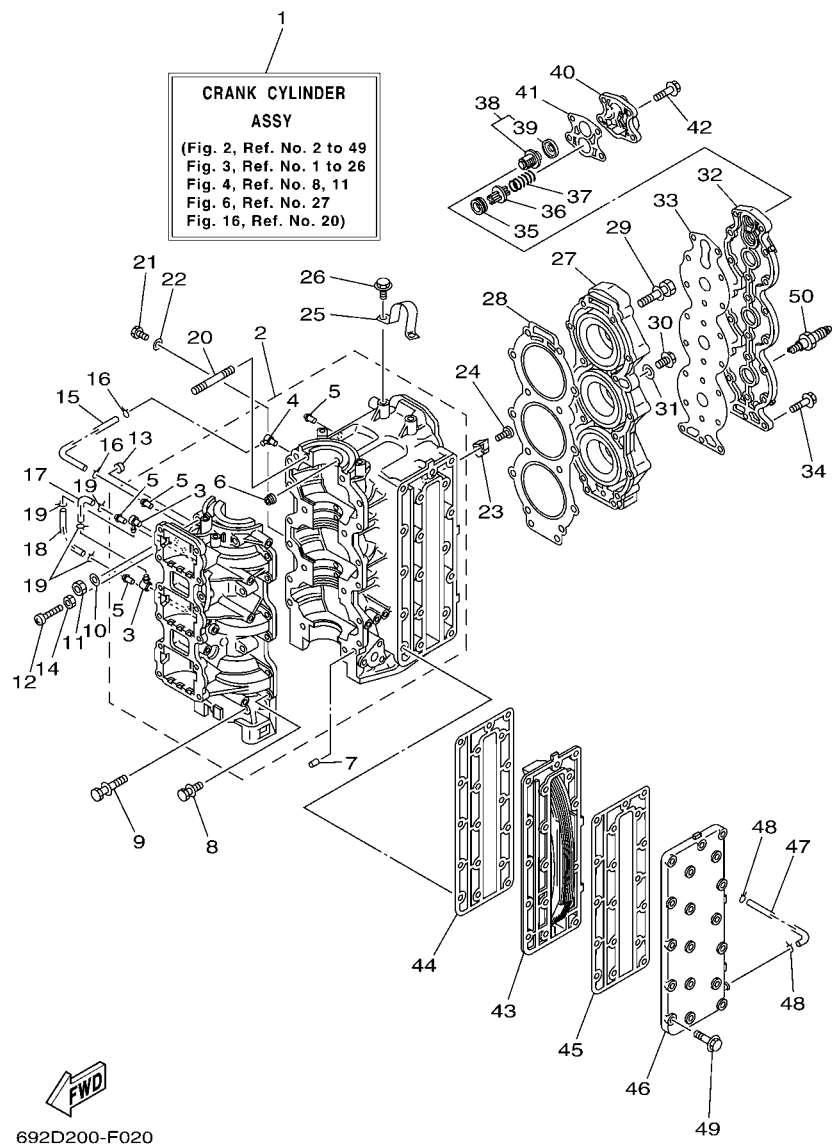

FIG. 2 CYLINDER & CRANKCASE CYLINDRO & CARTER

REF. NO.	PART NO. CODIGO Nº	DESCRIPTION DESCRIPCION	64S6	65S6	692F	REMARKS OBSERVACIONES
1	692-W0090-44-1S	CRANK CYLINDER ASSY BLOQUE MOTOR COMPLETO	1	1	1	
2	688-15100-06-1S	CRANKCASE ASSY CARTER COMPLETO	1	1	1	
3	688-11370-01	.CHECK VALVE ASSY .VALVULA DE CONTROL COMPL.	2	2	2	
4	650-11370-01	.CHECK VALVE ASSY .VALVULA DE CONTROL COMPL.	1	1	1	
5	624-14485-00	.PIPE, JOINT .TUBO DE UNION	4	4	4	
6	663-11518-01	.LOCK, BEARING .SEGURO BALERO	3	3	3	
7	93608-12063	PIN, DOWEL PASADOR DE CLAVIJA	2	2	2	
8	90119-06M12	BOLT, WITH WASHER TORNILLO CON ARANDELA	12	12	12	
9	90119-10005	BOLT, WITH WASHER TORNILLO CON ARANDELA	6	6	6	
10	90201-10008	WASHER, PLATE ARANDELA PLANA	2	2	2	
11	95313-10600	NUT TUERCA	2	2	2	
12	90157-06014	SCREW, PAN HEAD TORNILLO CABEZA CONICA PLANA	1	1	1	
13	688-44194-00	CAP TAPA	1	1	1	
14	95303-06700	NUT TUERCA	1	1	1	
15	90445-07260	HOSE (L276) TUBO (L276)	1	1	1	
16	90467-06016	CLIP PRESILLA	2	2	2	
17	90445-07M00	HOSE (L100) TUBO (L100)	1	1	1	
18	90445-07M23	HOSE (L408) TUBO (L408)	1	1	1	
19	90467-06016	CLIP PRESILLA	4	4	4	
20	90116-10M06	BOLT, STUD ESPARRAGO	2	2	2	
21	97095-06012	BOLT PERNO	1	1	1	
22	92995-06100	WASHER, SPRING ARANDELA	1	1	1	
23	688-11325-00	ANODE ANODO	2	2	2	
24	98780-04015	SCREW, FLAT HEAD TORNILLO CABEZA PLANA	2	2	2	
25	692-11119-01	HANGER, ENGINE SOPORTE DEL MOTOR	1	1	1	
26	90119-08MA3	BOLT, WITH WASHER TORNILLO CON ARANDELA	2	2	2	
27	692-11111-01-1S	HEAD, CYLINDER 1 CULATA CILINDRO 1	1	1	1	

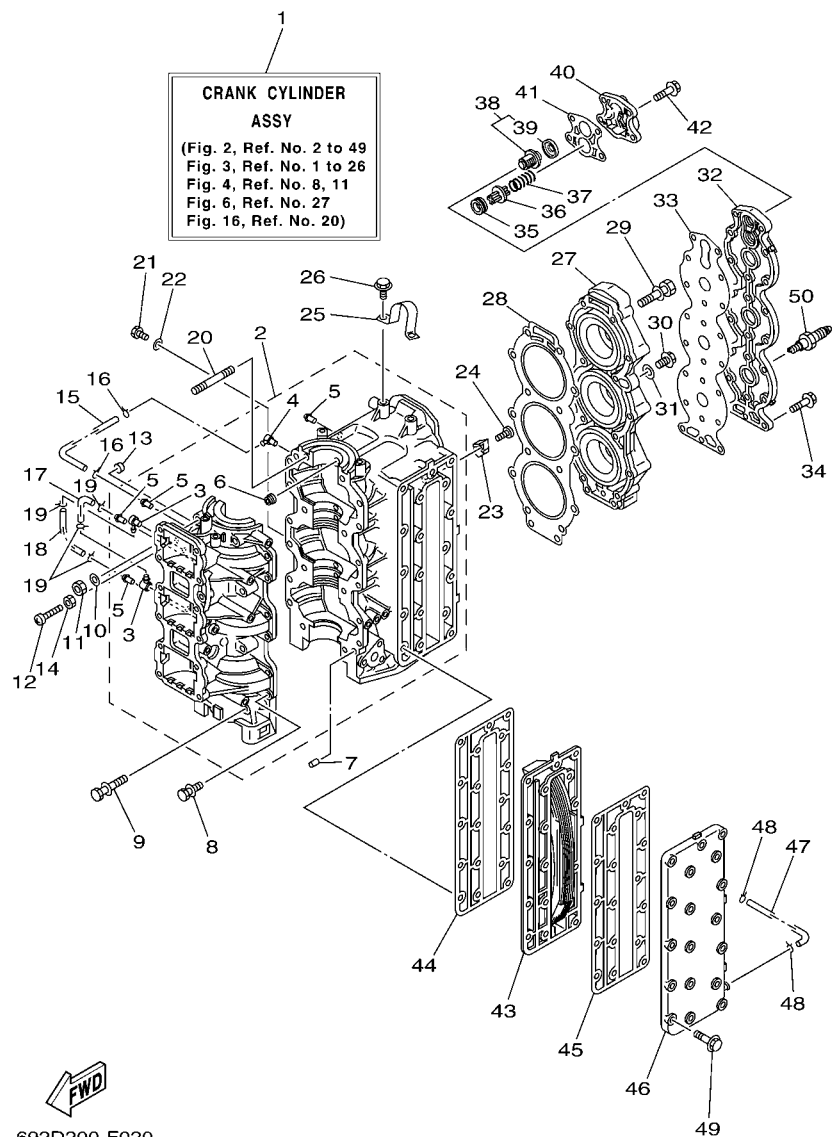
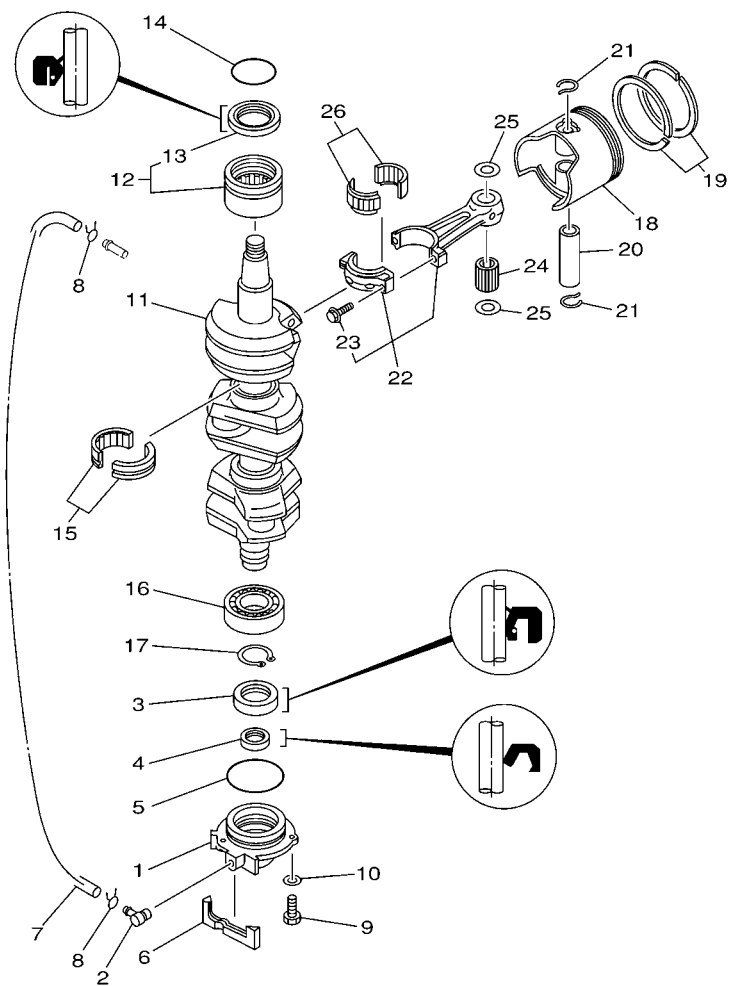

FIG. 2 CYLINDER & CRANKCASE CYLINDRO & CARTER

REF. NO.	PART NO. CODIGO Nº	DESCRIPTION DESCRIPCION	64S6	65S6	692F	REMARKS OBSERVACIONES
28	688-11181-A1	GASKET, CYLINDER HEAD 1 JUNTA, DE CULATA 1	1	1	1	
29	90119-08MA8	BOLT, WITH WASHER TORNILLO CON ARANDELA	14	14	14	
30	90340-14M00	PLUG, STRAIGHT SCREW TORNILLO, DE DRENAJE	1	1	1	
31	90430-14115	GASKET JUNTA	1	1	1	
32	688-11191-00-1S	COVER, CYLINDER HEAD 1 TAPA CULATA DE CILINDRO 1	1	1	1	
33	688-11193-A1	GASKET, HEAD COVER 1 EMPAQUE	1	1	1	
34	90119-06MA3	BOLT, WITH WASHER TORNILLO CON ARANDELA	18	18	18	
35	90480-20M05	GROMMET TAPON	1	1	1	
36	688-12416-00	VALVE, PRESSURE CONTROL VALVULA DE CONTROL DE PRESION	1	1	1	
37	90501-16M11	SPRING, COMPRESSION RESORTE DE COMPRESION	1	1	1	
38	688-12411-11	THERMOSTAT TERMOSTAT	1	1	1	
39	688-12412-00	.SEAL, THERMOSTAT .SELLO TERMOSTATO	1	1	1	
40	688-12413-00-1S	COVER, THERMOSTAT CUBIERTA TERMOSTATO	1	1	1	
41	688-12414-A1	GASKET, COVER EMPAQUE	1	1	1	
42	90119-06MA5	BOLT, WITH WASHER TORNILLO CON ARANDELA	4	4	4	
43	688-41111-00-1S	INNER COVER, EXHAUST CUBIERTA INTERIOR DE ESCAPE	1	1	1	
44	688-41112-A0	GASKET, EXHAUST INNER COVER EMPAQUE	1	1	1	
45	688-41114-A0	GASKET, EXHAUST OUTER COVER EMPAQUE	1	1	1	
46	688-41113-00-1S	OUTER COVER, EXHAUST CUBOERTA EXTERIOR DE ESCAPE	1	1	1	
47	663-24312-01	PIPE 2 TUBO 2	1	1	1	
48	90467-08004	CLIP PRESILLA	2	2	2	
49	90119-08020	BOLT, WITH WASHER TORNILLO CON ARANDELA	18	18	18	
50	94702-00160	PLUG, SPARK (NGK B8HS-10) BUJIA (NGK B8HS-10)	3	3		
	94702-00247	PLUG, SPARK (NGK BR8HS-10) BUJIA (NGK BR8HS-10)		3	3	E75B-FOR CAR(CE) E75B-FOR CAR(CE)



6H10010-0030

FIG. 3 CRANKSHAFT & PISTON CIGUENAL & PISTON

REF. NO.	PART NO. CODIGO Nº	DESCRIPTION DESCRIPCION	6456	6556	692F	REMARKS OBSERVACIONES
1	6H1-15359-01-94	HOUSING, OIL SEAL CAJA DE SELLO DE ACEITE	1	1	1	
2	688-11370-01	CHECK VALVE ASSY VALVULA DE CONTROL COMPL.	1	1	1	
3	93102-30M05	OIL SEAL SELLO ACEITE	1	1	1	
4	93104-20M02	OIL SEAL SELLO ACEITE	1	1	1	
5	93210-62269	O-RING ANILLO O	1	1	1	
6	688-15379-00	SEAL, CRANKCASE SELLO DE CARTER	1	1	1	
7	90445-07M86	HOSE (L460) TUBO (L460)	1	1	1	
8	90467-06016	CLIP PRESILLA	2	2	2	
9	97095-06020	BOLT PERNO	3	3	3	
10	92995-06600	WASHER ARANDELA	3	3	3	
11	688-11411-01	CRANKSHAFT CIGUENAL	1	1	1	
12	93310-636U4	BEARING COJINETE DE RODILLOS	1	1	1	
13	93102-36M02	OIL SEAL SELLO ACEITE	1	1	1	
14	93210-46M16	O-RING ANILLO O	1	1	1	
15	93310-835U8	BEARING COJINETE DE RODILLOS	2	2	2	
16	93306-206U5	BEARING COJINETE	1	1	1	
17	93410-32M00	CIRCLIP SEGURO	1	1	1	
18	688-11631-03-94	PISTON (STD) PISTON (NORMA)	3	3	3	
	688-11635-03	PISTON (0.25MM O/S) PISTON (0.25MM O/S)	3	3	3	AP AP
	688-11636-03	PISTON (0.50MM O/S) PISTON (0.50MM O/S)	3	3	3	AP AP
19	688-11603-A0	PISTON RING SET (STD) JUEGO DE ANILLOS (NORMA)	3	3	3	
	688-11604-A0	PISTON RING SET (0.25MM O/S) JUEGO DE ANILLOS (0.25MM O/S)	3	3	3	AP AP
	688-11605-A0	PISTON RING SET (0.50MM O/S) JUEGO DE ANILLOS (0.50MM O/S)	3	3	3	AP AP
20	663-11633-00	PIN, PISTON PASADOR, PISTON	3	3	3	
21	688-11634-00	CLIP, PISTON PIN PRESILLA, BULON DE PISTON	6	6	6	
22	688-11650-03	CONNECTING ROD ASSY BIELA COMPLETA	3	3	3	
23	90109-08022	BOLT PERNO	2	2	2	

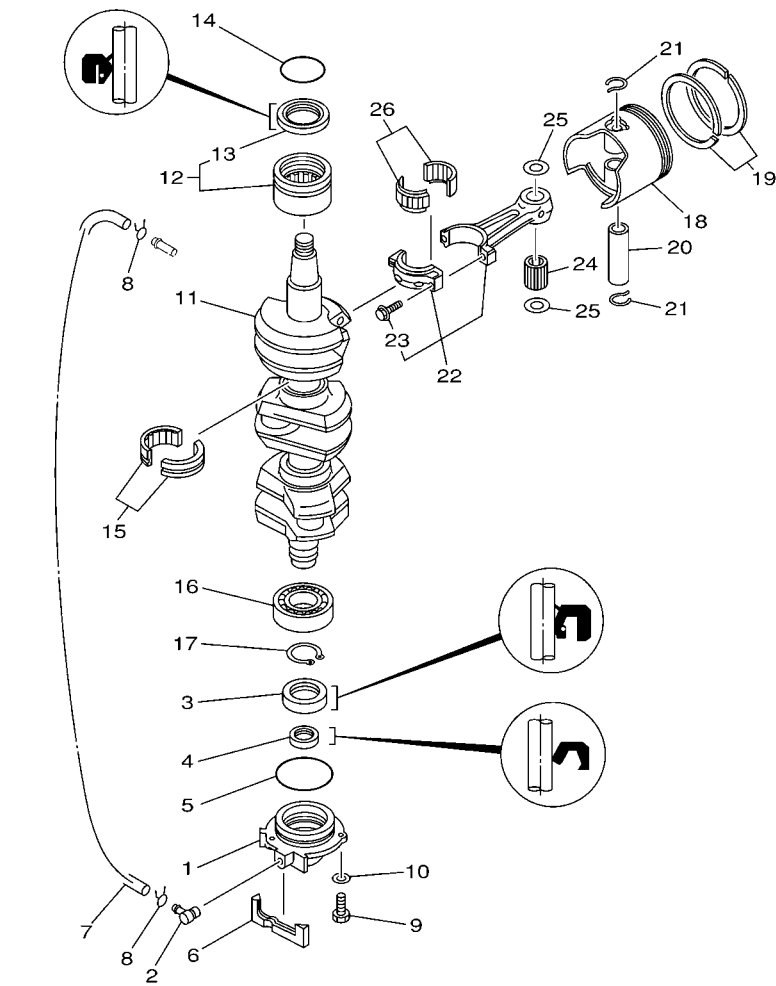

6H10010-0030

FIG. 3 CRANKSHAFT & PISTON

CIGUENAL & PISTON

REF. NO.	PART NO. CODIGO Nº	DESCRIPTION DESCRIPCION	64S6	65S6	692F	REMARKS OBSERVACIONES
24	93603-21111	PIN, DOWEL PASADOR DE CLAVIJA	84	84	84	
25	90201-20417	WASHER, PLATE ARANDELA PLANA	6	6	6	
26	93310-730V8	BEARING COJINETE DE RODILLOS	3	3	3	

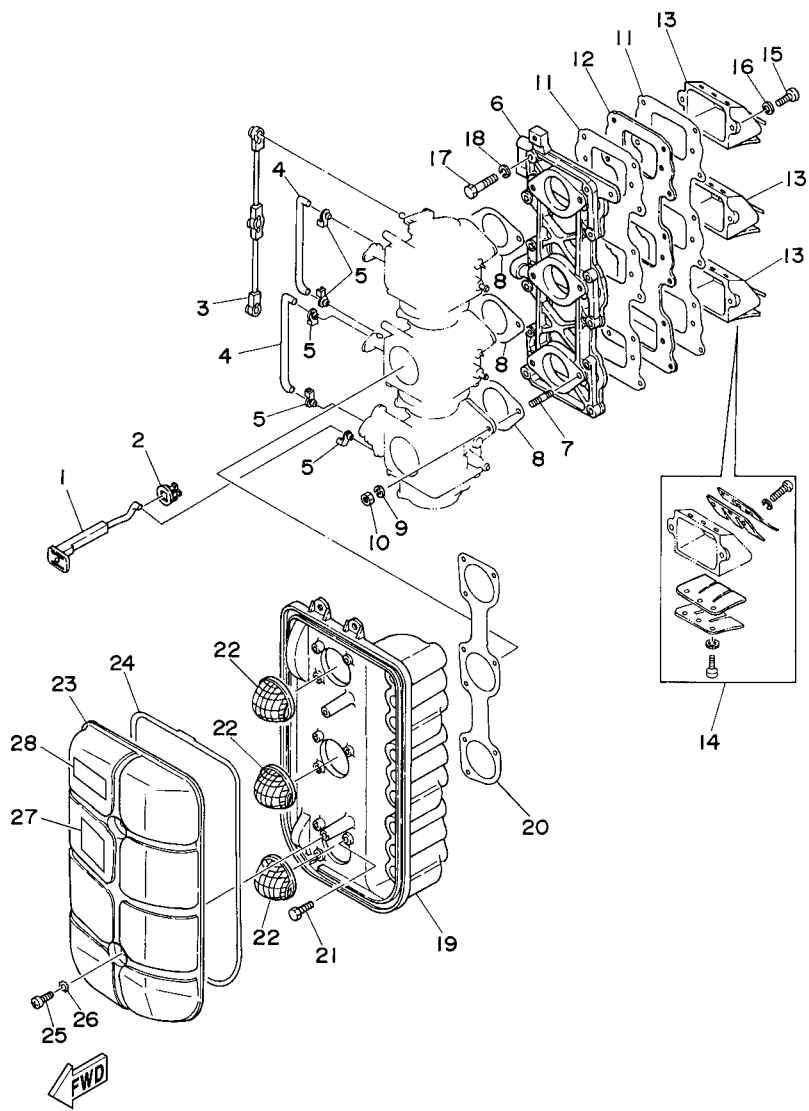

63S2561-C040

FIG. 4 INTAKE

ADMISION

REF. NO.	PART NO. CODIGO N°	DESCRIPTION DESCRIPCION	64S6	65S6	692F	REMARKS OBSERVACIONES
1	692-41256-00	ROD, CHOKE 1 VARILLA DE AHOGADOR	1	1	1	
2	689-41273-00	GROMMET	1	1	1	
3	688-41217-01	ROD, ACCEL. LEVER VARILLA PALANCA ACELERADOR	1	1	1	
4	688-41257-01	ROD, CHOKE 2 VARILLA DE AHOGADOR	2	2	2	
5	661-41262-02	JOINT, CHOKE LEVER CONECTOR DE AHOGADOR	5	5	5	
6	688-13641-00-94	MANIFOLD 1 MULTIPLE 1	1	1	1	
7	90116-06122	BOLT, STUD ESPARRAGO	6	6	6	
8	688-14198-A2	GASKET EMPAQUE	3	3	3	
9	92995-06100	WASHER, SPRING ARANDELA	6	6	6	
10	95380-06600	NUT, HEXAGON TUERCA	6	6	6	
11	688-13621-A1	GASKET, VALVE SEAT JUNTA, DE VALV.DE EMPAQUE	2	2	2	
12	688-13624-00	PLATE, REED VALVE PLACA DE VALVULA DE LAMINAS	1	1	1	
13	688-13610-00	REED VALVE ASSY VALVULA DE LAMINAS COMPLETA	3	3	3	
14	688-W0004-00	.REED SET .JUEGO DE VALVULAS DE LENGUETA	1	1	1	
15	97880-05020	SCREW, PAN HEAD TORNILLO DE CABEZA CON PLANA	6	6	6	
16	92990-05100	WASHER, SPRING ARANDELA PLANA	6	6	6	
17	97013-06030	BOLT PERNO	12	12	12	
18	92903-06100	WASHER, SPRING RONDANA SENCILLA	12	12	12	
19	688-14417-01-94	COVER 1 CUBIERTA 1	1	1	1	
20	688-14483-A0	GASKET EMPAQUE	1	1	1	
21	97013-06018	BOLT PERNO	6	6	6	
22	688-14481-00	CAP, CARBURETOR TAPA DE CARBURADOR	3	3	3	
23	688-14418-01	COVER 2 CUBIERTA 2	1	1	1	
24	688-14416-01	GASKET, AIR CLEANER EMPAQUE	1	1	1	
25	97885-06016	SCREW, PAN HEAD TORNILLO A MUESCA	2	2	2	
26	90209-06M05	WASHER ARANDELA DE SEPARACION	2	2	2	
27	6H1-14488-00	LABEL, CAUTION ETIQUETA PRECAUCION	1	1	1	

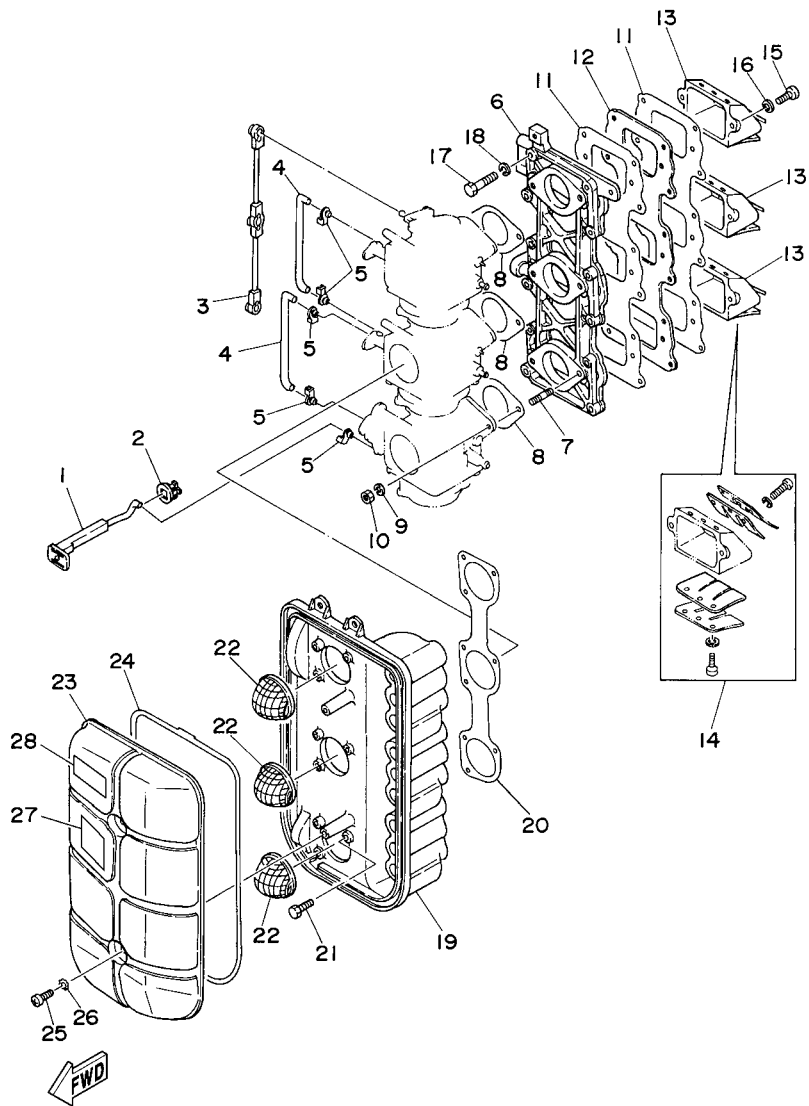

63S2561-C040

FIG. 4 INTAKE

ADMISION

REF. NO.	PART NO. CODIGO Nº	DESCRIPTION DESCRIPCION	64S6	65S6	692F	REMARKS OBSERVACIONES
28	6A1-83625-41	MARK 5 MARCA 5	1	1	1	

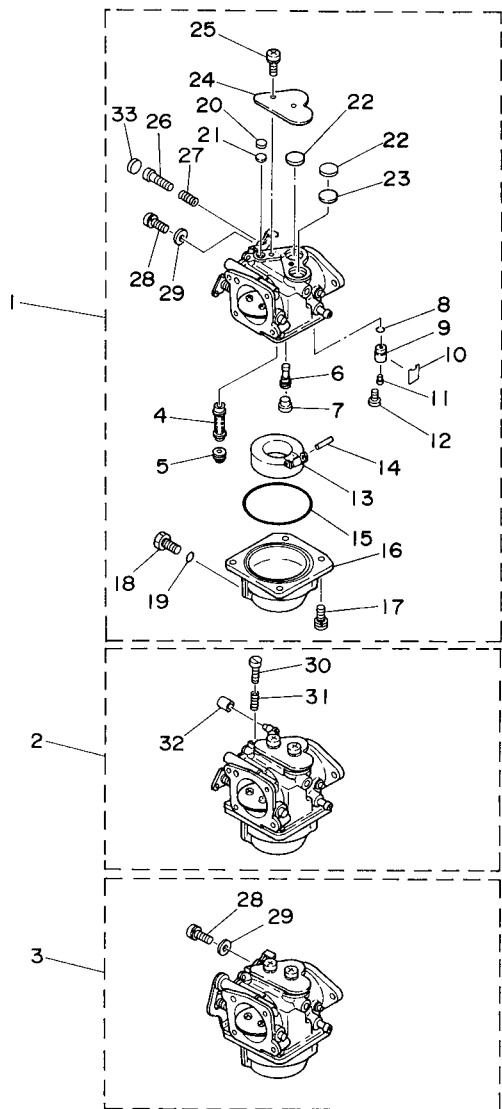

6927200-C050

FIG. 5 CARBURETOR

CARBURADOR

REF. NO.	PART NO. CODIGO Nº	DESCRIPTION DESCRIPCION	64S6	65S6	692F	REMARKS OBSERVACIONES
1	692-14301-45	CARBURETOR ASSY 1 CARBURADOR COMPLETO 1	1	1	1	
	692-14301-60	CARBURETOR ASSY 1 CARBURADOR COMPLETO 1			1	FOR CAR(EPA) FOR CAR(EPA)
2	692-14302-45	CARBURETOR ASSY 2 CARBURADOR COMPLETO 2	1	1	1	
	692-14302-60	CARBURETOR ASSY 2 CARBURADOR COMPLETO 2			1	FOR CAR(EPA) FOR CAR(EPA)
3	692-14303-45	CARBURETOR ASSY 3 CARBURADOR COMPLETO 3	1	1	1	
	692-14303-60	CARBURETOR ASSY 3 CARBURADOR COMPLETO 3			1	FOR CAR(EPA) FOR CAR(EPA)
4	692-14947-00	.JET, NEEDLE .INYECTOR DE AGUJA	3	3	3	
5	676-14943-41	.JET, MAIN (#170) .INYECTOR PRINCIPAL (#170)	3	3	3	
6	676-14948-18	.JET (#78) .INYECTOR (#78)	3	3	3	
7	676-14966-00	.CAP .TAPA	3	3	3	
8	93210-04228	.O-RING .ANILLO O	3	3	3	
9	692-14590-01	.NEEDLE VALVE ASSY .VALVULA DE AGUJA COMPLETA	3	3	3	
10	663-14159-00	.CLIP .PRESILLA	3	3	3	
11	676-14186-00	.PIN, FLOAT .PASADOR DE LA BOYA	3	3	3	
12	98580-04008	.SCREW, PAN HEAD .TORNILLO DE CABEZA CRUZADA	3	3	3	
13	676-14985-01	.FLOAT .BOIA	3	3	3	
14	688-14548-00	.PIN, FLOAT ARM .PASADOR DE BRAZO DE BOIA	3	3	3	
15	676-14984-00	.GASKET, FLOAT CHAMBER .EMPAQUE CAMARA DE BOIA	3	3	3	
16	688-14980-00	.BODY, FLOAT CHAMBER .CUERPO CAMARA DE BOIA	3	3	3	
17	97980-04114	.SCREW, WITH WASHER .TORNILLO, CON ARANDELA	12	12	12	
18	6H3-14992-00	.SCREW, DRAIN .TORNILLO, SEGURO	3	3	3	
19	93210-04230	.O-RING .ANILLO O	3	3	3	
20	663-14126-00	.GASKET .EMPAQUE	3	3	3	
21	663-14527-00	.PLATE .PLACA	3	3	3	
22	688-14126-00	.GASKET .EMPAQUE	6	6	6	
23	688-14527-00	.PLATE .PLACA	3	3	3	
24	688-14572-01	.PLATE, STAY .PLACA DE SOPORTE	3	3	3	

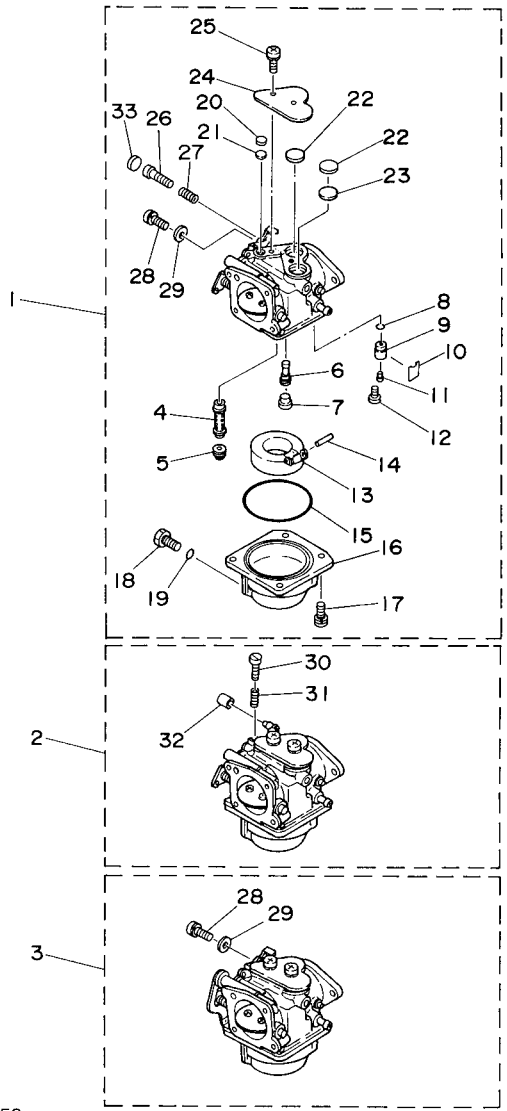

6927200-C050

FIG. 5 CARBURETOR CARBURADOR

REF. NO.	PART NO. CODIGO Nº	DESCRIPTION DESCRIPCION	64S6	65S6	692F	REMARKS OBSERVACIONES
25	97980-05310	.SCREW, WITH WASHER .TORNILLO, CON ARANDELA	6	6	6	
26	692-14923-00	.SCREW, PILOT .TORNILLO DE AJUSTE	3	3	3	
27	679-14555-00	.SPRING .RESORTE	3	3	3	
28	6K5-14592-00	.SCREW .TORNILLO	2	2	2	#1,3 #1,3
29	90201-05652	.WASHER, PLATE .ARANDELA PLANA	2	2	2	#1,3 #1,3
30	63V-14523-00	.SCREW, STOP .TORNILLO DE TOPE	1	1	1	#2 #2
31	90501-10326	.SPRING, COMPRESSION .RESORTE DE COMPRESION	1	1	1	#2 #2
32	6H2-14578-00	.COLLAR .COLLAR	1	1	1	#2 #2
33	67C-1432A-00	.PLUG .TAPON			3	FOR CAR(EPA) FOR CAR(EPA)

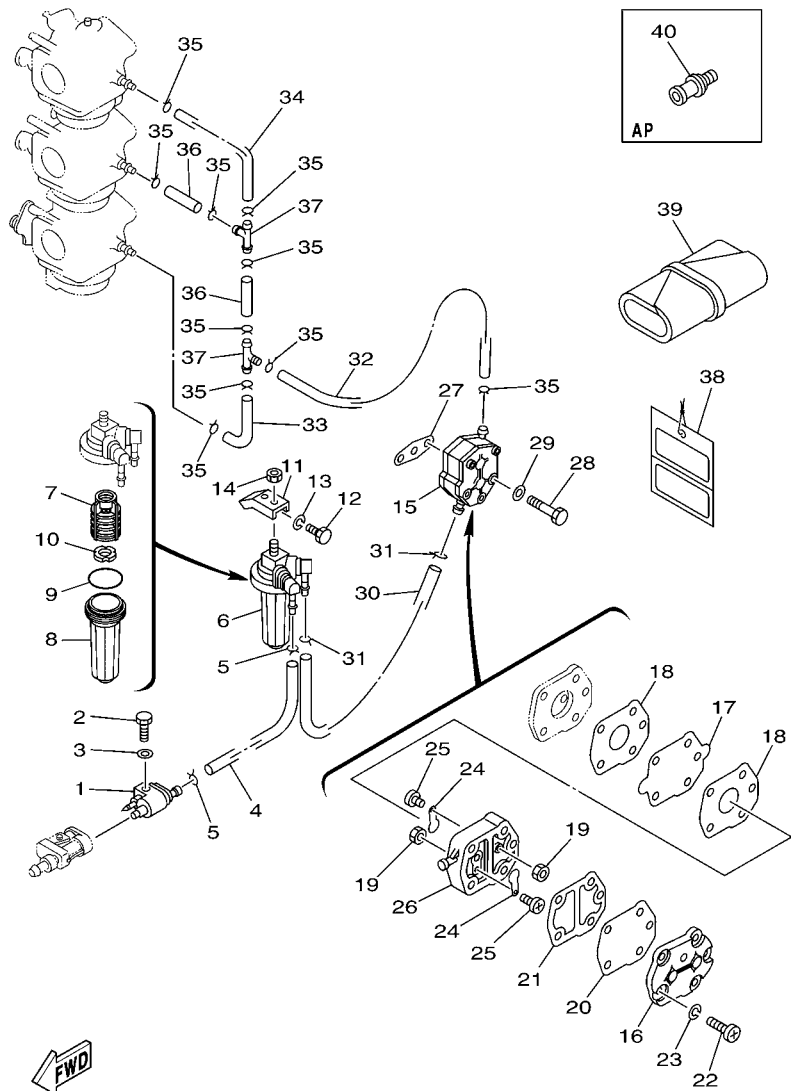

6883700-C060

FIG. 6 FUEL

COMBUSTIBLE

REF. NO.	PART NO. CODIGO N°	DESCRIPTION DESCRIPCION	64S6	65S6	692F	REMARKS OBSERVACIONES
1	6G1-24304-02	FUEL PIPE JOINT COMP. 1 CONECTOR MANGUERA COMBUST.1	1	1	1	
2	97095-06020	BOLT PERNO	1	1	1	
3	92995-06600	WASHER ARANDELA	1	1	1	
4	90445-09090	HOSE (L185) TUBO (L185)	1	1	1	
5	90467-08004	CLIP PRESILLA	2	2	2	
6	64J-24560-00	FILTER ASSY FILTRO COMPLETO	1	1	1	
7	61N-24563-00	.ELEMENT, FILTER .ELEMENTO DEL FILTRO	1	1	1	
8	68V-24521-01	.CUP, FILTER .COPA DE FILTRO	1	1	1	
9	93210-32738	.O-RING .ANILLO O	1	1	1	
10	68V-24469-01	.FLOAT, WATER LEVEL .BOIA	1	1	1	
11	648-24566-02	BRACKET, FILTER SOPORTE DEL FILTRO	1	1	1	
12	97013-06014	BOLT PERNO	1	1	1	
13	92903-06100	WASHER, SPRING RONDANA SENCILLA	1	1	1	
14	95380-08600	NUT TUERCA	1	1	1	
15	692-24410-00	FUEL PUMP ASSY BOMBA DE COMBUSTIBLE COMPLETA	1	1	1	
16	6A0-24413-00	.BODY 2 .CUERPO 2	1	1	1	
17	692-24411-00	.DIAPHRAGM .DIAFRAGMA	1	1	1	
18	648-24434-01	.GASKET, BODY .EMPAQUE	2	2	2	
19	95380-03600	.NUT .TUERCA	2	2	2	
20	663-24411-00	.DIAPHRAGM .DIAFRAGMA	1	1	1	
21	648-24435-02	.GASKET, BODY 2 .EMPAQUE	1	1	1	
22	98503-05028	.SCREW, PAN HEAD .TORNILLO DE CABEZA DE CONO ACH	3	3	3	
23	92990-05100	.WASHER, SPRING .ARANDELA PLANA	3	3	3	
24	6A0-24421-01	.VALVE, CHECK .VALVULA DE RETENCION	2	2	2	
25	6A0-14325-00	.SCREW, PAN HEAD .TORNILLO CABEZA REDONDA	2	2	2	
26	6A0-24412-02	.BODY 1 .CUERPO 1	1	1	1	
27	650-24431-A0	GASKET, FUEL PUMP 1 EMPAQUE BOMBA COMBUST 1	1	1	1	

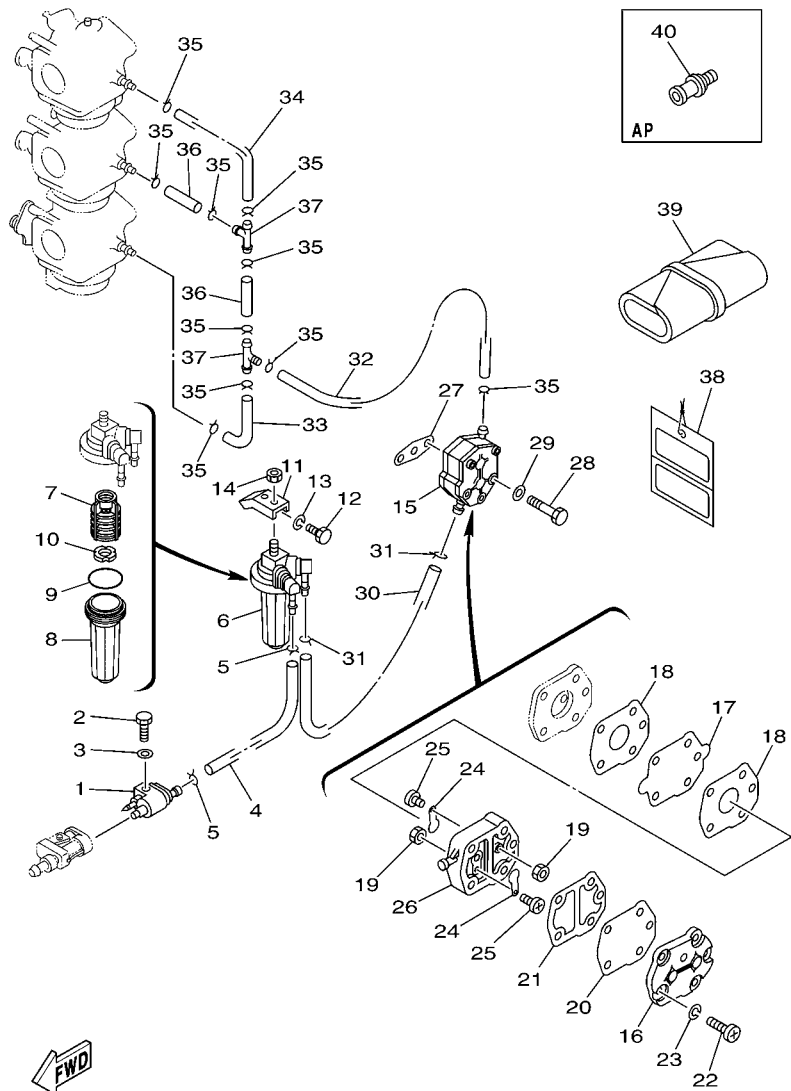

6883700-C060

FIG. 6 FUEL

COMBUSTIBLE

REF. NO.	PART NO. CODIGO Nº	DESCRIPTION DESCRIPCION	64S6	65S6	692F	REMARKS OBSERVACIONES
28	97095-06040	BOLT PERNO	2	2	2	
29	92995-06600	WASHER ARANDELA	2	2	2	
30	90445-09221	HOSE (L205) TUBO (L205)	1	1	1	
31	90467-08004	CLIP PRESILLA	2	2	2	
32	90445-09097	HOSE (L250) TUBO (L250)	1	1	1	
33	688-24313-00	PIPE 3 TUBO 3	1	1	1	
34	688-24314-00	PIPE 4 TUBO 4	1	1	1	
35	90467-08004	CLIP PRESILLA	10	10	10	
36	90445-09220	HOSE (L30) TUBO (L30)	2	2	2	
37	688-24378-00	PIPE, JOINT 3 TUBO DE UNION 3	2	2	2	
38	61H-2819R-31	TAG, WARNING ETIQUETA DE ADVERTENCIA	1	1	1	FOR CAR FOR CAR
39	670-28100-03	TOOL KIT JUEGO DE HERRAMIENTAS	1	1	1	
40	6E0-28193-00-94	PLUG, WATER CHECK TAPON DE CONTROL DE LA AGUA	1	1	1	AP D:12.5MM AP D:12.5MM

FIG. 7 STARTER

ARRANQUE

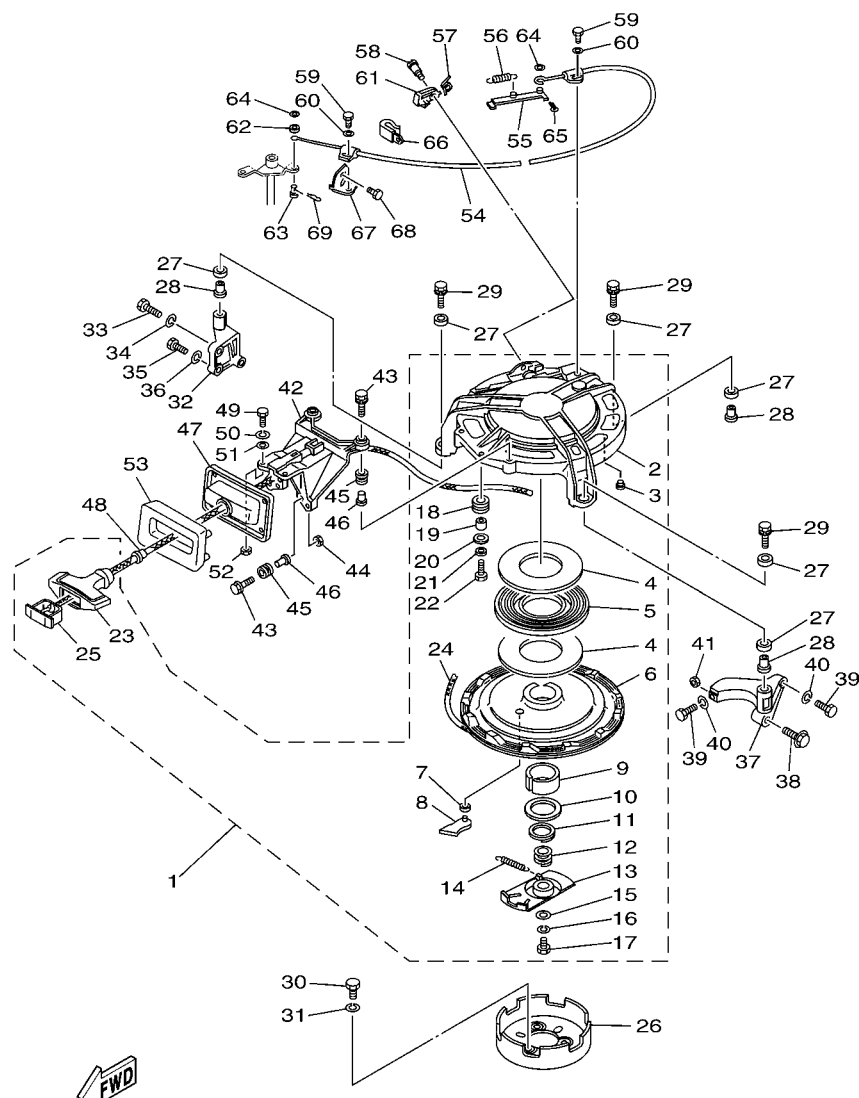

6929200-D070

*1: CUT FROM 50M ROLLS, PART NO. 90890-44374, CUTTING LENGTH 2.3M

*1: CORTE DE UN RODILLO DE 50M , PARTS NUMERO 90890-44374, LARGO DEL CORTE 2.3M

REF. NO.	PART NO. CODIGO N°	DESCRIPTION DESCRIPCION	64S6	65S6	692F	REMARKS OBSERVACIONES
1	692-W1571-02	STARTER ASSY ARRANQUE COMPLETO	1	1	1	
2	692-15711-00	.CASE, STARTER .CAJA DE ARRANQUE	1	1	1	
3	648-15773-00	.STAY 3 .SOPORTE 3	5	5	5	
4	663-15739-00	.WASHER, THRUST .ARANDELA DE EMPUJE AXIAL	2	2	2	
5	663-15713-00	.SPRING, STARTER .RESORTE DE ARRANQUE	1	1	1	
6	663-15714-01	.DRUM, SHEAVE .TAMBOR ROLDANA	1	1	1	
7	663-15764-00	.COLLAR 1 .COLLAR 1	1	1	1	
8	663-15741-02	.PAWL, DRIVE .TRINQUETE DE TRACCION	1	1	1	
9	663-15754-00	.BUSH 2 .BUJE 2	1	1	1	
10	663-15726-01	.WASHER, FLAT .ARANDELA PLANA	1	1	1	
11	663-15744-00	.CIRCLIP .SEGURO	1	1	1	
12	663-15715-00	.SPRING, FRICTION .RESORTE PLACA DE TRACCION	1	1	1	
13	663-15716-01	.PLATE, DRIVE .PLACA DE TRACCION	1	1	1	
14	663-15734-01	.SPRING, RETURN .RESORTE DE RETORNO	1	1	1	
15	663-15719-00	.WASHER, THRUST .ARANDELA DE EMPUJE	1	1	1	
16	92903-06100	.WASHER, SPRING .RONDANA SENCILLA	1	1	1	
17	97303-06016	.BOLT .TORNILLO	1	1	1	
18	663-15752-00	.ROLLER, WIRE .RODILLO DE CUERDA	1	1	1	
19	663-15753-00	.BUSH .BUJE	1	1	1	
20	663-15791-00	.WASHER, LOCK .EMBLEMA	1	1	1	
21	92903-06100	.WASHER, SPRING .RONDANA SENCILLA	1	1	1	
22	97303-06025	.BOLT .TORNILLO	1	1	1	
23	689-15755-01	.HANDLE, STARTER .MANIJA DE ARRANQUE	1	1	1	
24	*	.WIRE (L:2300MM) .CABLE (L:2300MM)	1	1	1	*1 *1
25	6F5-15779-02	.COVER .CUBIERTA	1	1	1	
26	6K5-15723-00	PULLEY, STARTER POLEA DE ARRANQUE	1	1	1	
27	90385-12M04	BUSH BUJE	6	6	6	

FIG. 7 STARTER

ARRANQUE

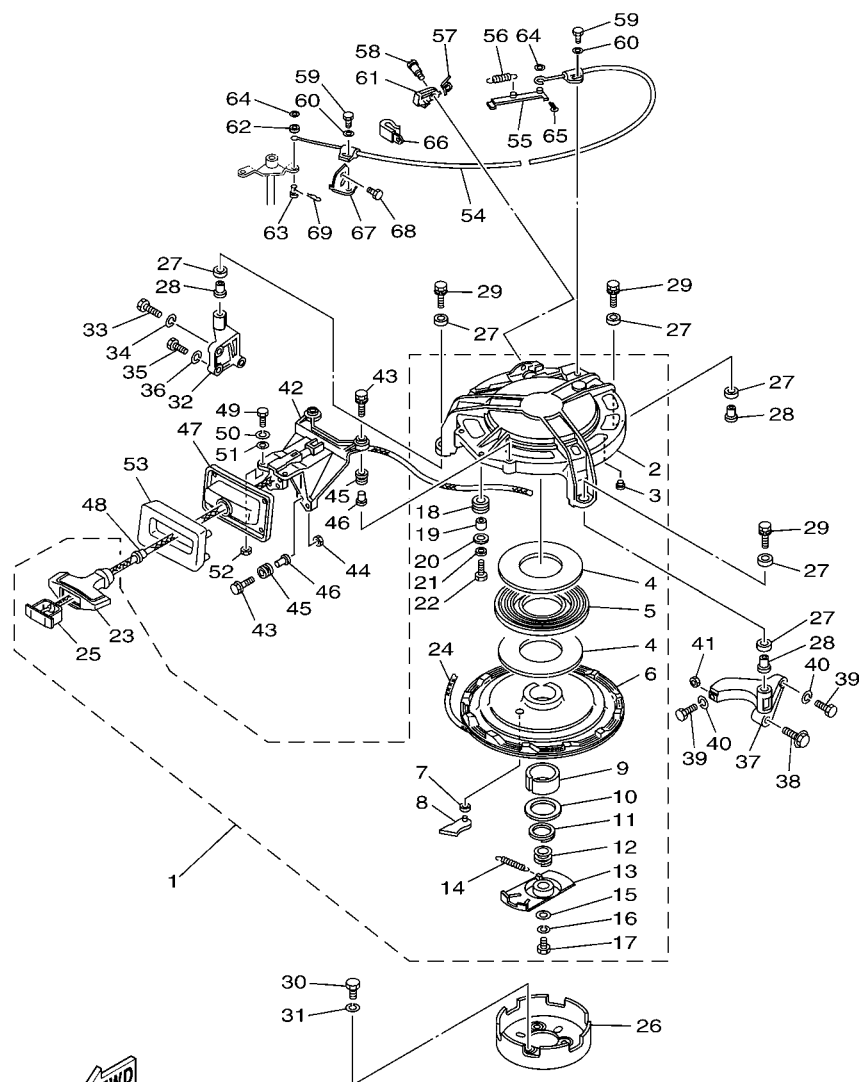

6929200-D070

*1: CUT FROM 50M ROLLS, PART NO. 90890-44374, CUTTING LENGTH 2.3M
 *1: CORTE DE UN RODILLO DE 50M , PARTS NUMERO 90890-44374, LARGO DEL CORTE 2.3M

REF. NO.	PART NO. CODIGO N°	DESCRIPTION DESCRIPCION	64S6	65S6	692F	REMARKS OBSERVACIONES
28	90387-08M05	COLLAR ESPACIADOR	3	3	3	
29	90119-08M26	BOLT, WITH WASHER TORNILLO CON ARANDELA	3	3	3	
30	97013-08016	BOLT PERNO	3	3	3	
31	92903-08100	WASHER, SPRING RONDANA SENCILLA	3	3	3	
32	692-15771-00	STAY 1 SOPORTE 1	1	1	1	
33	97013-06035	BOLT PERNO	1	1	1	
34	92903-06100	WASHER, SPRING RONDANA SENCILLA	1	1	1	
35	97013-06025	BOLT PERNO	2	2	2	
36	92903-06100	WASHER, SPRING RONDANA SENCILLA	2	2	2	
37	692-15772-00	STAY 2 SOPORTE 2	1	1	1	
38	97513-08440	BOLT, WITH WASHER PERNO CON ARANDELA	1	1	1	
39	97013-06030	BOLT PERNO	2	2	2	
40	92903-06100	WASHER, SPRING RONDANA SENCILLA	2	2	2	
41	95303-06600	NUT TUERCA	1	1	1	
42	697-15787-00-94	ADAPTOR ADAPTADOR	1	1	1	
43	90119-06M30	BOLT, WITH WASHER TORNILLO CON ARANDELA	4	4	4	
44	95303-06600	NUT TUERCA	2	2	2	
45	6A0-82317-00	DAMPER, IGNITION COIL AMORTIGUADOR BOBINA ENCENDIDO	4	4	4	
46	90387-06119	COLLAR ESPACIADOR	4	4	4	
47	692-15758-01-94	GUIDE, ROPE GUIA DE CUERDA	1	1	1	
48	697-15789-00	DAMPÉR AMORTIGUADOR	1	1	1	
49	97095-06020	BOLT PERNO	2	2	2	
50	92995-06100	WASHER, SPRING ARANDELA	2	2	2	
51	92995-06600	WASHER ARANDELA	2	2	2	
52	95303-06600	NUT TUERCA	2	2	2	
53	697-15762-00	SEAL, RUBBER 2 SELLO DE GOMA 2	1	1	1	
54	692-15770-01	CABLE COMP., STARTER STOP CABLECOMPL DE SEGURO ARRANQUE	1	1	1	

FIG. 7 STARTER

ARRANQUE

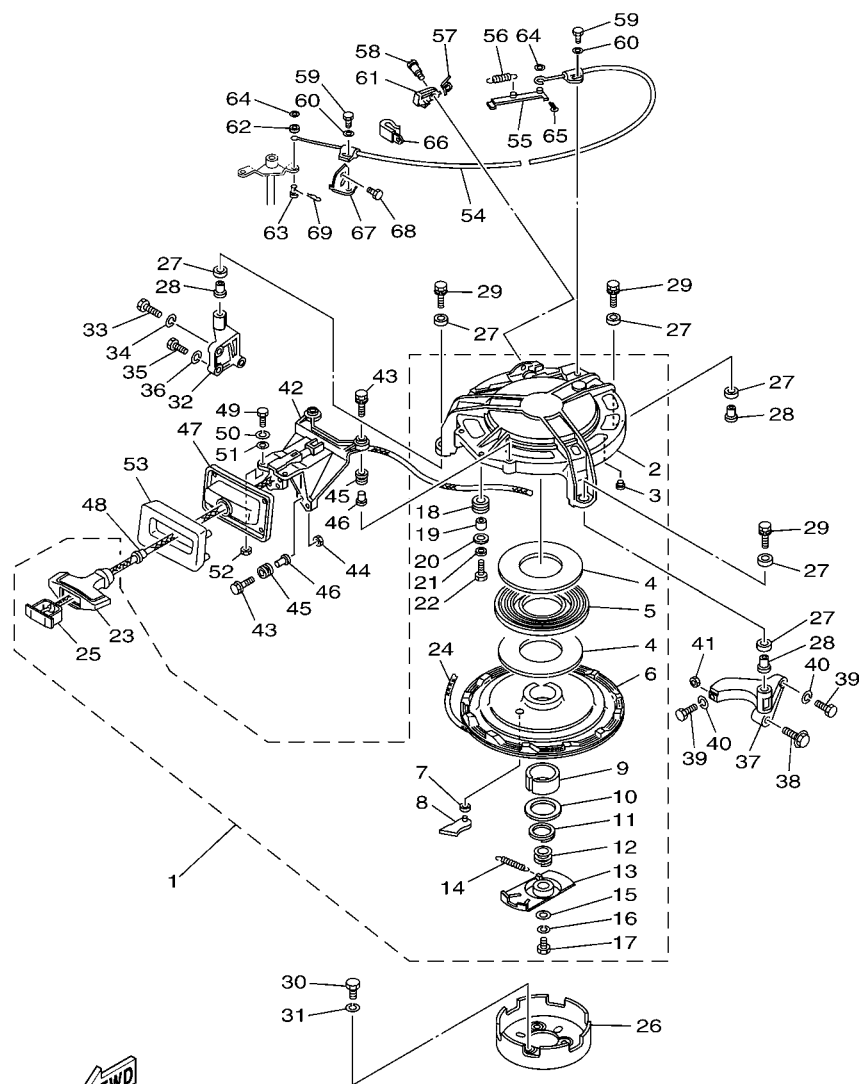

6929200-D070

*1: CUT FROM 50M ROLLS, PART NO. 90890-44374, CUTTING LENGTH 2.3M

*1: CORTE DE UN RODILLO DE 50M , PARTS NUMERO 90890-44374, LARGO DEL CORTE 2.3M

REF. NO.	PART NO. CODIGO N°	DESCRIPTION DESCRIPCION	64S6	65S6	692F	REMARKS OBSERVACIONES
55	663-15735-01	GUIDE, CAM GUIA DE LEVA	1	1	1	
56	90506-08M23	SPRING, TENSION RESORTE DE TENSION	1	1	1	
57	90508-12015	SPRING, TORSION RESORTE DE TORSION	1	1	1	
58	90149-05095	SCREW TORNILLO DE REGLAJE	1	1	1	
59	97095-06012	BOLT PERNO	2	2	2	
60	92995-06600	WASHER ARANDELA	2	2	2	
61	663-15794-00	STOPPER TOPE	1	1	1	
62	663-15736-00	RING, RETAINING 1 ANILLO DE RETEN	1	1	1	
63	90240-06M18	PIN, CLEVIS PASADOR CON HOYO	1	1	1	
64	92995-06200	WASHER ARANDELA	2	2	2	
65	91490-16012	PIN, COTTER CHAVETA	1	1	1	
66	90465-06M90	CLAMP BRIDA	1	1	1	
67	663-15772-01	STAY 2 SOPORTE 2	1	1	1	
68	97013-08012	BOLT PERNO	1	1	1	
69	90468-18008	CLIP PRESILLA	1	1	1	

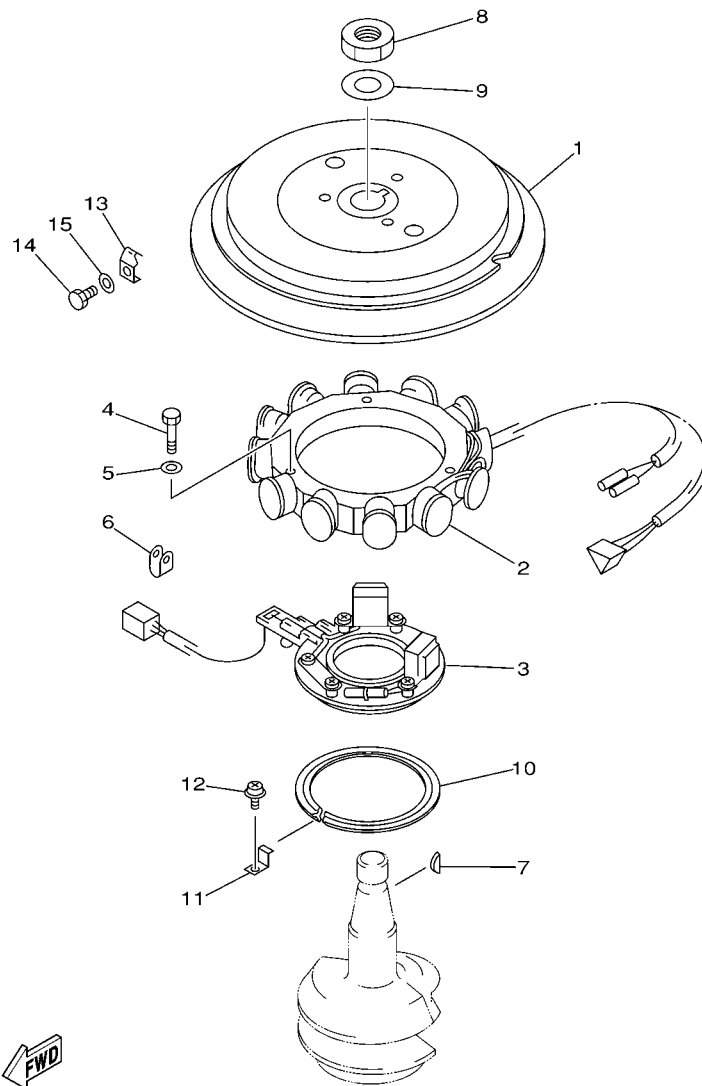



6920100-0090

FIG. 8 GENERATOR

GENERADOR

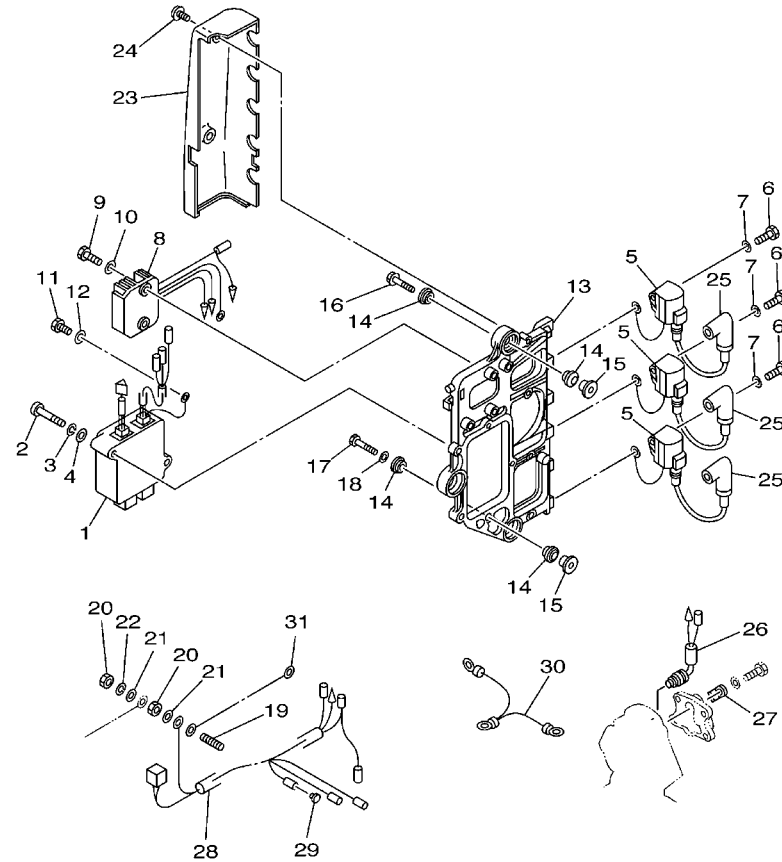
REF. NO.	PART NO. CODIGO Nº	DESCRIPTION DESCRIPCION	64S6	65S6	692F	REMARKS OBSERVACIONES
1	692-85550-00	ROTOR ASSY ROTOR COMPLETO	1	1	1	
2	688-85510-01	STATOR ASSY ESTATOR COMPLETO	1	1	1	
3	688-85580-00	COIL, PULSER BOBINA DE PULSACION	1	1	1	
4	97013-06030	BOLT PERNO	3	3	3	
5	92903-06600	WASHER, PLATE RONDANA SENCILLA	3	3	3	
6	90464-12M00	CLAMP BRIDA	1	1	1	
7	90280-05015	KEY, WOODRUFF CUNA WOODRUFF	1	1	1	
8	90170-20137	NUT TUERCA	1	1	1	
9	90201-21M18	WASHER, PLATE ARANDELA PLANA	1	1	1	
10	688-41611-00	RETAINER, MAGNETO BASE RETENEDOR BASE MAGNETO	1	1	1	
11	688-41612-00	RETAINER, MAGNETO BASE RETENEDOR BASE MAGNETO	3	3	3	
12	90159-06M31	SCREW, WITH WASHER TORNILLO CON VALONA	3	3	3	
13	688-81332-01	PLATE, TIMING PLACA REGULADOR DE TIEMPO	1	1	1	
14	97095-06010	BOLT PERNO	1	1	1	
15	92995-06600	WASHER ARANDELA	1	1	1	



6920100-0101

FIG. 9 ELECTRICAL

ELECTRICO

REF. NO.	PART NO. CODIGO Nº	DESCRIPTION DESCRIPCION	64S6	65S6	692F	REMARKS OBSERVACIONES
1	688-85540-00	C.D.I. UNIT ASSY UNIDAD C.D.I. COMPLETA	1	1	1	
2	97880-06040	SCREW, PAN HEAD TORNILLO DE CABEZA CON PLANA	2	2	2	
3	92990-06100	WASHER, SPRING ARANDELA PLANA	2	2	2	
4	92990-06600	WASHER, PLATE ARANDELA PLANA	2	2	2	
5	697-85570-00	IGNITION COIL ASSY BOBINA DE IGNICION COMPLETO	3	3	3	
6	97095-06020	BOLT PERNO	3	3	3	
7	92995-06600	WASHER ARANDELA	3	3	3	
8	6H0-81960-00	RECTIFIER & REGULATOR ASSY RECTIFICADOR Y REGULADOR	1	1	1	
9	97095-06020	BOLT PERNO	2	2	2	
10	92995-06600	WASHER ARANDELA	2	2	2	
11	97013-06016	BOLT PERNO	1	1	1	
12	92903-06600	WASHER, PLATE RONDANA SENCILLA	1	1	1	
13	6H1-85542-00-94	BRACKET SOPORTE	1	1	1	
14	90480-09M25	GROMMET TAPON	6	6	6	
15	90387-06M03	COLLAR ESPACIADOR	3	3	3	
16	90119-06M75	BOLT, WITH WASHER TORNILLO CON ARANDELA	2	2	2	
17	90109-06M39	BOLT PERNO	1	1	1	
18	90201-06M31	WASHER, PLATE ARANDELA PLANA	1	1	1	
19	90116-06M22	BOLT, STUD ESPARRAGO	1	1	1	
20	95380-06700	NUT TUERCA	2	2	2	
21	92990-06200	WASHER, PLAIN ARANDELA PLANA	2	2	2	
22	92990-06100	WASHER, SPRING ARANDELA PLANA	1	1	1	
23	6H1-81916-00	COVER, TERMINAL CUBIERTA DE TERMINAL	1	1	1	
24	90159-06M11	SCREW, WITH WASHER TORNILLO CON VALONA	2	2	2	
25	663-82370-01	PLUG CAP ASSY TAPON DE BUJIA COMPLT	3	3	3	
25	6G1-82370-21	PLUG CAP ASSY TAPON DE BUJIA COMPLT	3	3	3	E75B-FOR CAR(CE) E75B-FOR CAR(CE)
26	688-82560-10	THERMO SWITCH ASSY INTER. DE TERMO	1	1	1	

FIG. 9 ELECTRICAL

ELECTRICO

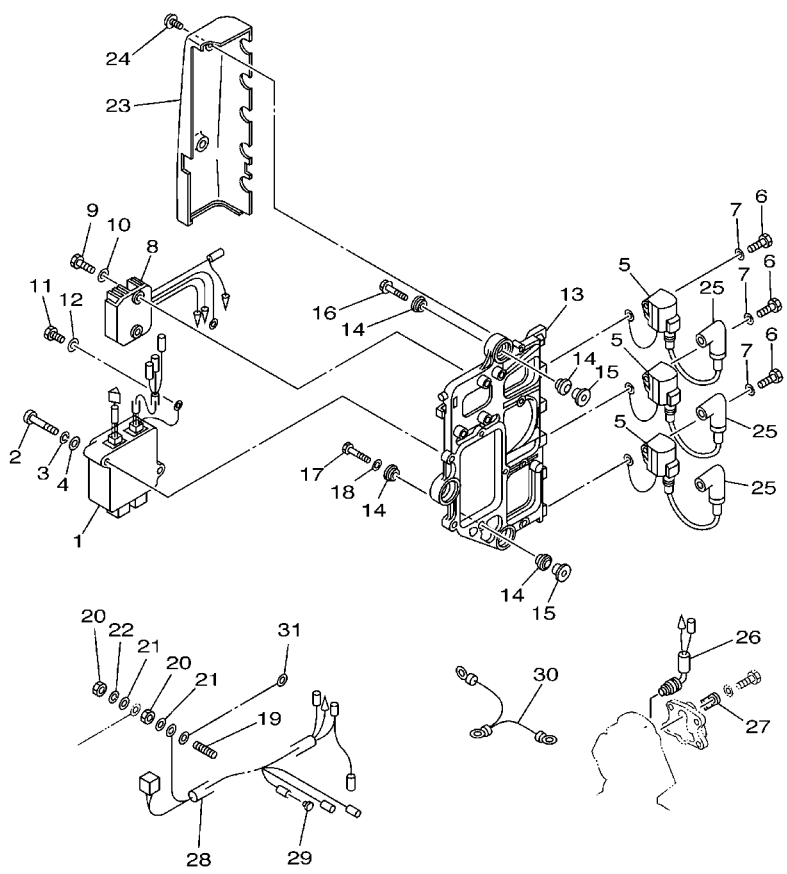

REF. NO.	PART NO. CODIGO Nº	DESCRIPTION DESCRIPCION	64S6	65S6	692F	REMARKS OBSERVACIONES
27	688-82588-01	PLATE PLACA	1	1	1	
28	692-82590-00	WIRE HARNESS ASSY CONJUNTO DE CABLES	1	1	1	
29	703-82119-00	COVER, LEAD WIRE CUBIERTA DE CABLE CONDUCTOR	1	1	1	
30	697-82519-00	WIRE, EARTH LEAD CABLE CONDUCTOR A TIERRA	1	1	1	
31	61A-82519-00	WIRE, EARTH LEAD CABLE CONDUCTOR A TIERRA	1	1	1	



6920100-0101

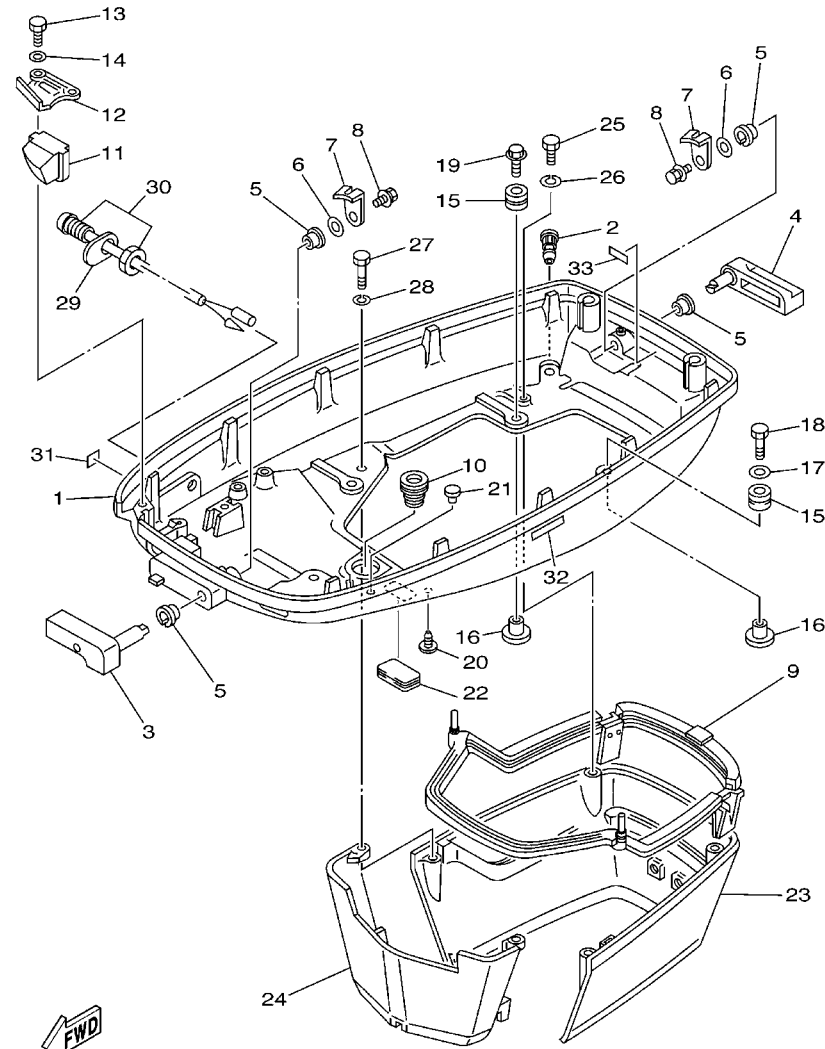

6923200-2100

FIG. 10 BOTTOM COWLING

CUBIERTA INFERIOR

REF. NO.	PART NO. CODIGO Nº	DESCRIPTION DESCRIPCION	64S6	65S6	692F	REMARKS OBSERVACIONES
1	692-42711-02-4D	COWLING, BOTTOM 1 CUBIERTA INFERIOR 1	1	1	1	
2	6H3-44391-01	NIPPLE, HOSE NIPLE MANGUERA	1	1	1	
3	688-42815-01-4D	LEVER, CLAMP PALANCA ABRAZADERA	1	1	1	
4	688-42817-01-4D	LEVER, CLAMP PALANCA ABRAZADERA	1	1	1	
5	90386-13M38	BUSH BUJE	4	4	4	
6	90206-13019	WASHER, WAVE ARANDELA ONDULADA	2	2	2	
7	688-42816-00	LEVER, CLAMP PALANCA ABRAZADERA	2	2	2	
8	90119-06M09	BOLT, WITH WASHER TORNILLO CON ARANDELA	2	2	2	
9	688-42716-02	RUBBER, SEAL 1 SELLO DE GOMA 1	1	1	1	
10	663-42724-00	GROMMET TAPON	1	1	1	
11	692-42725-10	GROMMET TAPON	1	1	1	
12	688-42738-01-94	PLATE, FITTING PLACA DE AJUSTE	1	1	1	
13	97095-06016	BOLT PERNO	2	2	2	
14	92995-06600	WASHER ARANDELA	2	2	2	
15	90480-09M12	GROMMET TAPON	4	4	4	
16	90387-06M69	COLLAR ESPACIADOR	4	4	4	
17	90201-06416	WASHER, PLATE ARANDELA PLANA	1	1	1	
18	97095-06030	BOLT PERNO	1	1	1	
19	90119-06M61	BOLT, WITH WASHER TORNILLO CON ARANDELA	3	3	3	
20	90338-05M03	PLUG TAPON	1	1	1	
21	703-82119-00	COVER, LEAD WIRE CUBIERTA DE CABLE CONDUCTOR	1	1	1	
22	6H4-42726-00	GROMMET TAPON	1	1	1	
23	688-42741-01-4D	APRON MANDIL	1	1	1	
24	688-42771-01-4D	APRON MANDIL	1	1	1	
25	97095-06020	BOLT PERNO	2	2	2	
26	92995-06100	WASHER, SPRING ARANDELA	2	2	2	
27	97095-06030	BOLT PERNO	2	2	2	

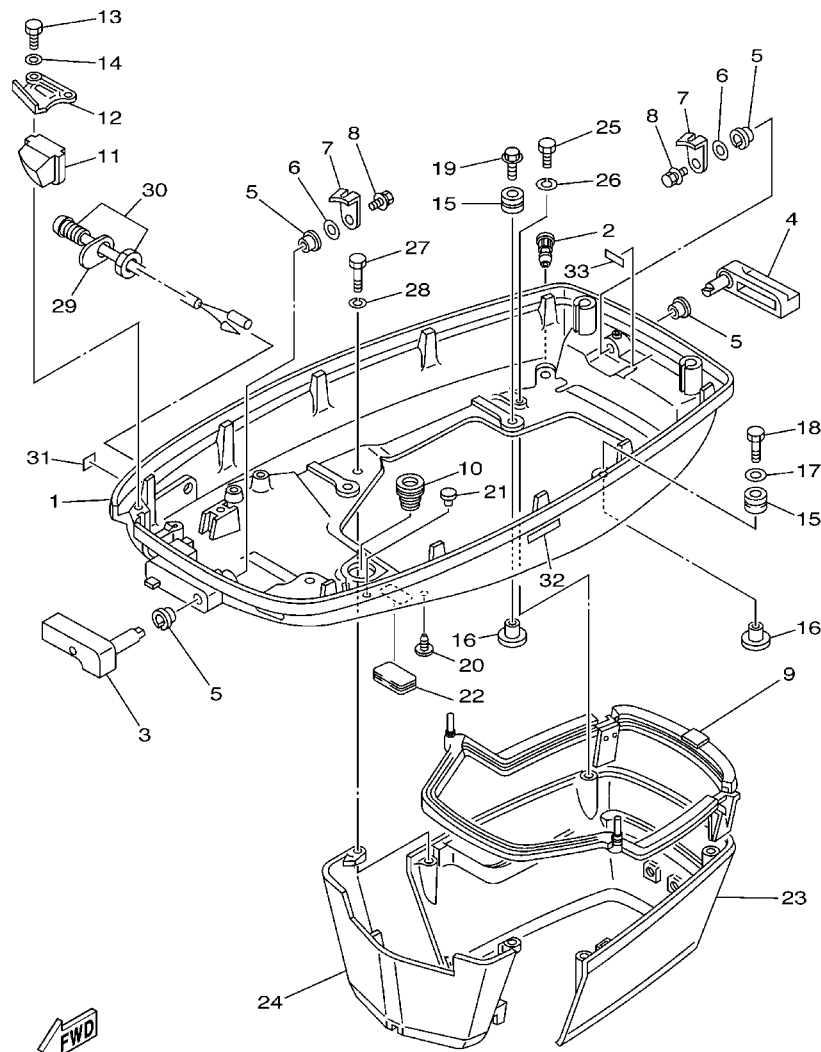

6923200-2100

FIG. 10 BOTTOM COWLING

CUBIERTA INFERIOR

REF. NO.	PART NO. CODIGO Nº	DESCRIPTION DESCRIPCION	64S6	65S6	692F	REMARKS OBSERVACIONES
28	92995-06100	WASHER, SPRING ARANDELA	2	2	2	
29	692-85415-00	MARK, SIGNAL LAMP MARCO DE FOCO DE SENAL	1	1	1	
30	6H4-85411-00	OVERHEAT WARNING LAMP CALENTAR DEMASIADO DEL ALARMA	1	1	1	
31	6A1-28176-00	LABEL, CAUTION ETIQUETA DE PRECAUCION		1	1	FOR CAR(CE) FOR CAR(CE)
32	6E3-8257H-00	PLATE, MARK PLACA DE MARCA		1	1	FOR CAR(CE) FOR CAR(CE)
33	6G5-42791-00	MARK 1 MARCA 1	1		1	
	6G5-42791-10	MARK 1 MARCA 1		1	1	E75B-FOR CAR(CE) E75B-FOR CAR(CE)

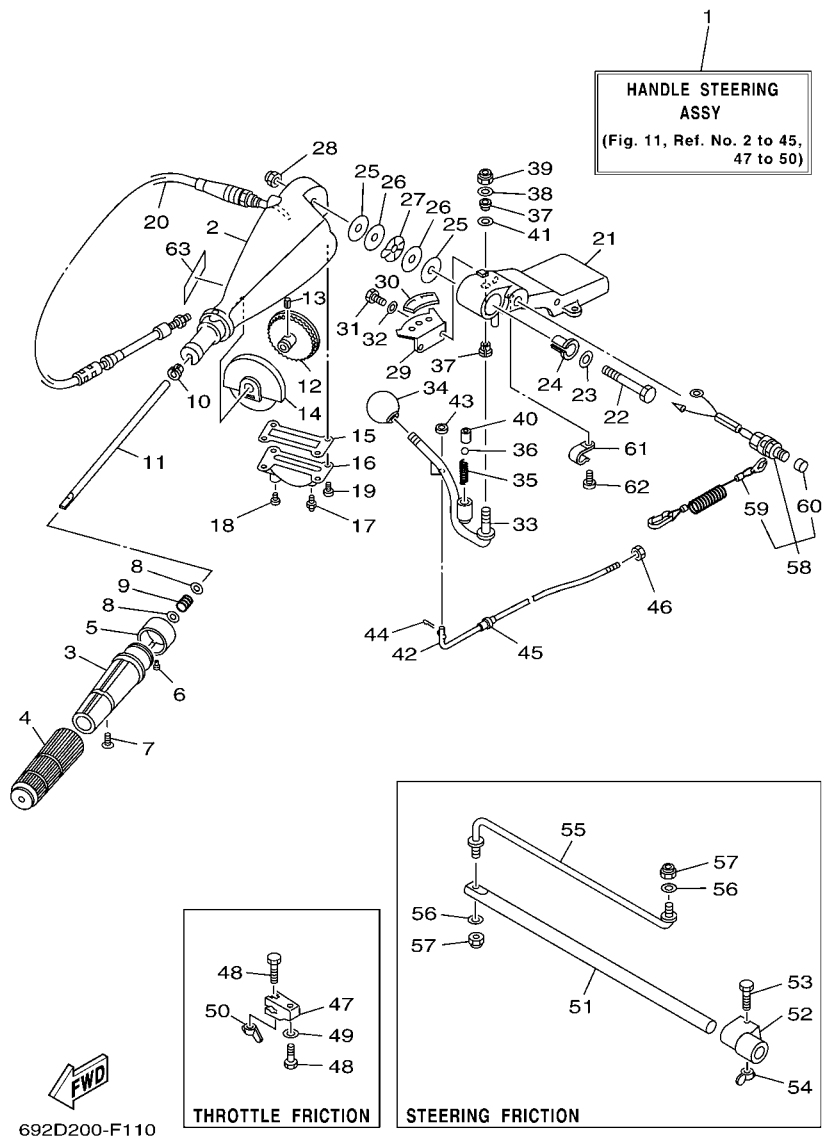

FIG. 11 STEERING

DIRECCION

REF. NO.	PART NO. CODIGO Nº	DESCRIPTION DESCRIPCION	64S6	65S6	692F	REMARKS OBSERVACIONES
1	692-W0084-11-4D	HANDLE STEERING ASSY CONJUNTO DE MANIJA	1	1	1	
2	692-42111-12-4D	HANDLE, STEERING MANIJA DE DIRECCION	1	1	1	
3	664-42119-00	GRIP, STEERING HANDLE MANGO, MANIJA DE DIRRECCION	1	1	1	
4	6F6-42177-A0	RUBBER, HANDLE HULE DE MANIJA	1	1	1	
5	692-42137-02	INDICATOR, THROTTLE INDICADOR ACELERADOR	1	1	1	
6	90269-02M09	RIVET REMACHE	1	1	1	
7	90149-05M13	SCREW TORNILLO DE REGLAJE	1	1	1	
8	90201-10M02	WASHER, PLATE ARANDELA PLANA	2	2	2	
9	90501-23215	SPRING, COMPRESSION RESORTE DE COMPRESION	1	1	1	
10	90386-08032	BUSH BUJE	1	1	1	
11	692-42115-00	SHAFT, STEERING HANDLE EJE MANIJA DE DIRECCION	1	1	1	
12	663-42138-00	LEVER, THROTTLE PLANCA DE ACELERACION	1	1	1	
13	90254-03003	PIN, SPRING PASADOR DE TIPO A RESORTE	1	1	1	
14	692-42135-00	HOUSING, THROTTLE LEVER CAJA PALANCA ACELERADOR	1	1	1	
15	663-42133-01	GASKET EMPAQUE	1	1	1	
16	692-42134-03-94	COVER, THROTTLE LEVER CUBIERTA PALANCA ACELERADOR	1	1	1	
17	93700-06M03	NIPPLE, GREASE BOQUILLA DE ENGRASAR	1	1	1	
18	97885-06008	SCREW, PAN HEAD TORNILLO A MUESCA	1	1	1	
19	97885-05012	SCREW, PAN HEAD TORNILLO A MUESCA	4	4	4	
20	692-26301-03	THROTTLE CABLE ASSY CABLE DE ACELERADOR COMPLETO	1	1	1	
21	692-42121-02-4D	BRACKET SOPORTE	1	1	1	
22	90101-12M06	BOLT TORNILLO	1	1	1	
23	92990-12200	WASHER, PLAIN ARANDELA PLANA	1	1	1	
24	90386-12089	BUSH BUJE	1	1	1	
25	90202-12092	WASHER, PLATE ARANDELA DE PLANA	2	2	2	
26	90201-12537	WASHER, PLATE ARANDELA PLANA	2	2	2	
27	90206-12054	WASHER, WAVE ARANDELA ONDULADA	1	1	1	

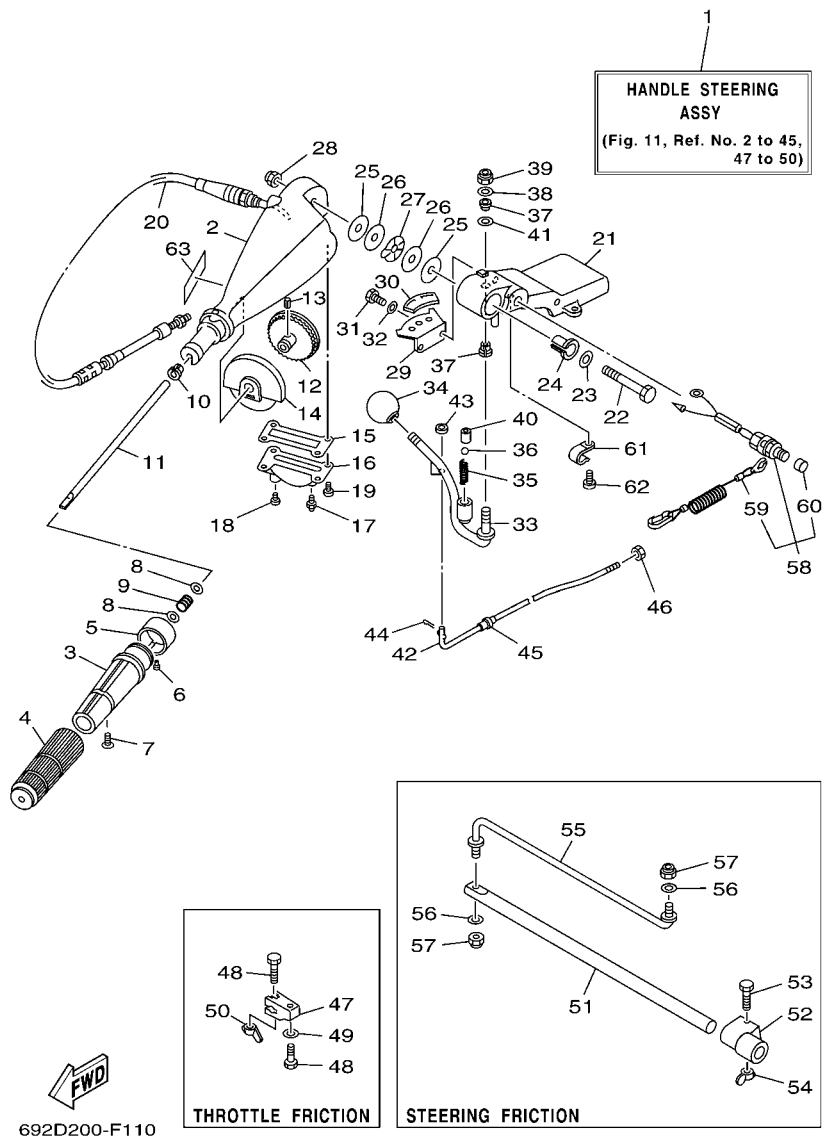

FIG. 11 STEERING

DIRECCION

REF. NO.	PART NO. CODIGO Nº	DESCRIPTION DESCRIPCION	64S6	65S6	692F	REMARKS OBSERVACIONES
28	90185-12058	NUT, SELF-LOCKING TUERCA AUTOBLOCANTE	1	1	1	
29	697-44113-00	CAM PLATE, HANDLE PLACA DE LA LEVA DEL MANGO	1	1	1	
30	6K5-44191-00	INDICATOR, SHIFT INDICADOR DE CAMBIOS	1	1	1	
31	97013-06016	BOLT PERNO	2	2	2	
32	92903-06100	WASHER, SPRING RONDANA SENCILLA	2	2	2	
33	692-44159-01	HANDLE, GEAR SHIFT MANIJA DE CAMBIO DE MARCHAS	1	1	1	
34	663-44173-00	LEVER, SHIFT CONTROL PALANCA CONTROL CAMBIOS	1	1	1	
35	90501-16M17	SPRING, COMPRESSION RESORTE DE COMPRESION	1	1	1	
36	93515-32M01	BALL ESFERA	1	1	1	
37	90386-10009	BUSH BUJE	2	2	2	
38	90201-10120	WASHER, PLATE ARANDELA PLANA	1	1	1	
39	90185-10051	NUT, SELF-LOCKING TUERCA AUTOBLOCANTE	1	1	1	
40	90387-12M30	COLLAR ESPACIADOR	1	1	1	
41	90201-12M34	WASHER, PLATE ARANDELA PLANA	1	1	1	
42	692-42164-00	ROD, MANUAL SHIFT VARILLA DE CAMBIOS MANUAL	1	1	1	
43	92990-06600	WASHER, PLATE ARANDELA PLANA	1	1	1	
44	91490-25012	PIN, COTTER CHAVETA	1	1	1	
45	90386-06088	BUSH BUJE	1	1	1	
46	700-48339-00	NUT, CABLE END TUERCA TERMINAL	1	1	1	
47	663-42126-01	FRICTION, STEERING HANDLE GRIP FRICCION DE MANGO DIRECCION	1	1	1	
48	90101-06M27	BOLT TORNILLO	2	2	2	
49	92990-06600	WASHER, PLATE ARANDELA PLANA	1	1	1	
50	90175-06003	NUT, WING TUERCA MARIPOSA	1	1	1	
51	663-42518-00	SHAFT, FRICTION EJE FRICCION	1	1		
52	663-42528-00	PLATE, FRICTION PIEZA DE FRICCION	1	1		
53	97080-06035	BOLT PERNO	1	1		
54	90175-06003	NUT, WING TUERCA MARIPOSA	1	1		

FIG. 11 STEERING

DIRECCION

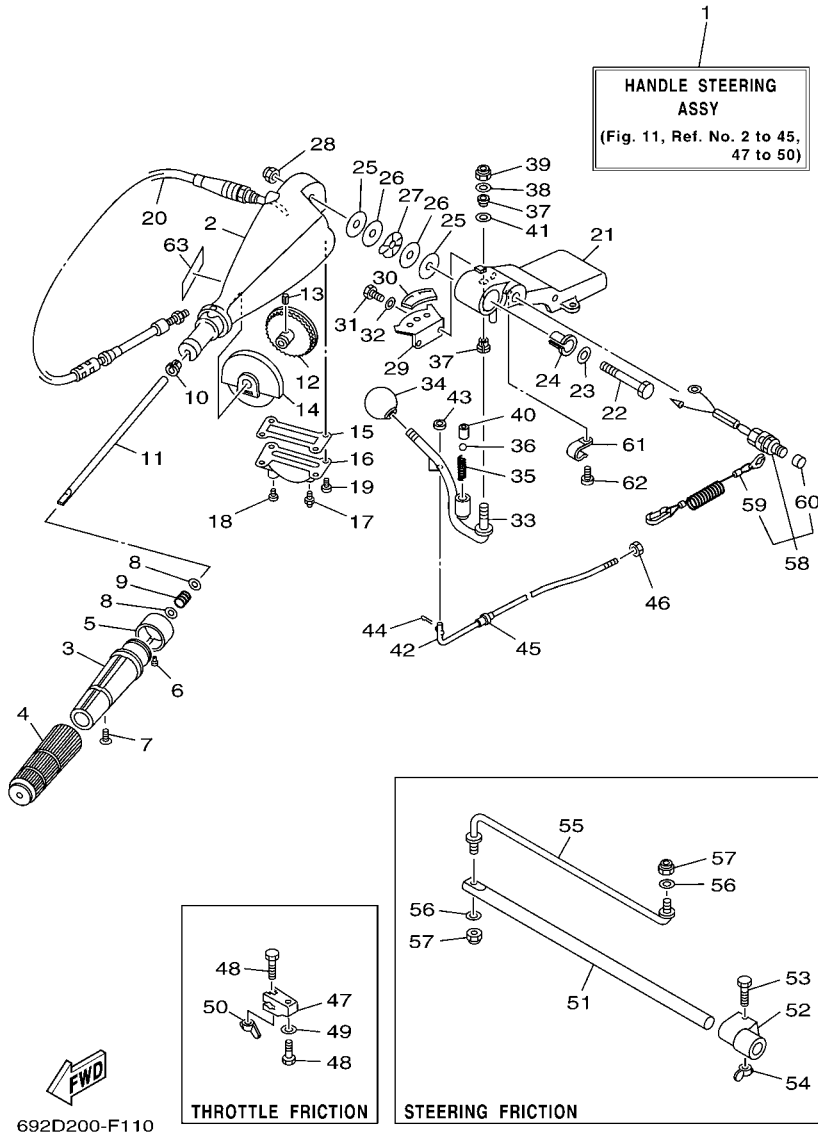

REF. NO.	PART NO. CODIGO Nº	DESCRIPTION DESCRIPCION	64S6	65S6	692F	REMARKS OBSERVACIONES
55	692-42515-01	ROD, STEERING LINK VARILLA ESLABON DIRECCION	1	1		
56	92990-08600	WASHER, PLATE ARANDELA PLANA	2	2		
57	90185-08057	NUT, SELF-LOCKING TUERCA AUTOBLOCANTE	2	2		
58	697-82575-00	ENGINE STOP SWITCH ASSY INTERRUPTOR DE PARADA COMPL	1	1	1	
59	682-82556-00	.LANYARD, STOP SWITCH .RETENER	1	1	1	
60	689-8257Y-00	.CAP .CASQUILLO	1	1	1	
61	90465-06M90	CLAMP BRIDA	1	1	1	
62	97885-06012	SCREW, PAN HEAD TORNILLO A MUESCA	1	1	1	
63	6E0-83627-41	LABEL, CAUTION 7 ETIQUETA DE PRECAUCION 7	1	1	1	

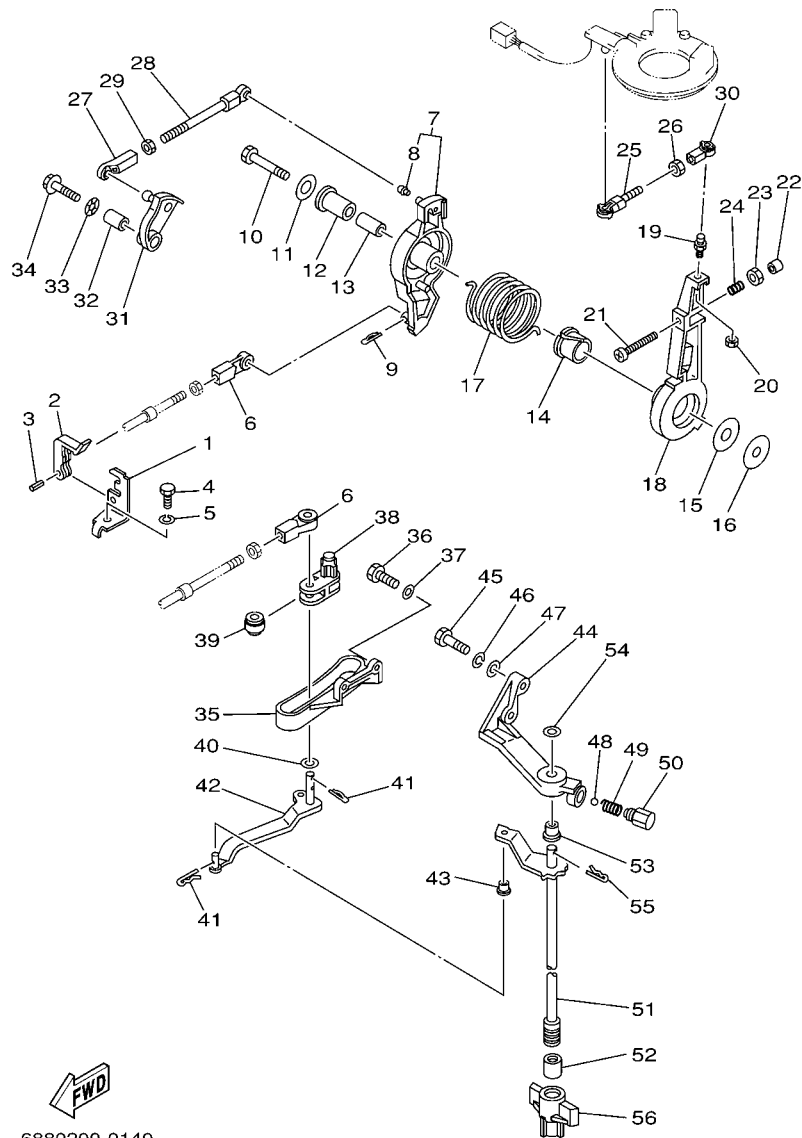

6880200-0140

FIG. 12 CONTROL

CONTROL

REF. NO.	PART NO. CODIGO Nº	DESCRIPTION DESCRIPCION	64S6	65S6	692F	REMARKS OBSERVACIONES
1	663-48531-00	BRACKET, REMOTE CONTROL SOPORTE DE CONTROL REMOTO	1	1	1	
2	663-48538-00	CLAMP, CABLE 1 GRAMPA DE CABLE	1	1	1	
3	91690-30012	PIN, SPRING PASADOR DE RESORTE	1	1	1	
4	97095-08016	BOLT PERNO	1	1	1	
5	92995-08100	WASHER ARANDELA	1	1	1	
6	663-48344-00	CABLE END, REMOTE CONTROL BASE CONTROL	2	2	2	
7	688-41632-01-94	LEVER, MAGNETO CONTROL PALANCA DE CONTROL DE MAGNETO	1	1	1	
8	662-41214-01	.JOINT 1 .CONECTOR	1	1	1	
9	90468-18008	CLIP PRESILLA	1	1	1	
10	97095-08045	BOLT PERNO	1	1	1	
11	90201-08M23	WASHER, PLATE ARANDELA PLANA	1	1	1	
12	90386-12089	BUSH BUJE	1	1	1	
13	90387-08M16	COLLAR ESPACIADOR	1	1	1	
14	90386-22M13	BUSH BUJE	1	1	1	
15	90202-12092	WASHER, PLATE ARANDELA DE PLANA	1	1	1	
16	90201-08M13	WASHER, PLATE ARANDELA PLANA	1	1	1	
17	90508-29M05	SPRING, TORSION RESORTE DE TORSION	1	1	1	
18	688-41631-01-94	LEVER, MAGNETO CONTROL PALANCA DE CONTROL DE MAGNETO	1	1	1	
19	663-85518-00	JOINT, BALL CONECTOR	1	1	1	
20	95303-05700	NUT TUERCA	1	1	1	
21	90157-06013	SCREW, PAN HEAD TORNILLO CABEZA CONICA PLANA	1	1	1	
22	688-44194-00	CAP TAPA	1	1	1	
23	95303-06600	NUT TUERCA	1	1	1	
24	90501-16M12	SPRING, COMPRESSION RESORTE DE COMPRESION	1	1	1	
25	682-41237-50	JOINT, LINK CONECTOR	1	1	1	
26	95380-05600	NUT TUERCA	1	1	1	
27	682-41237-00	JOINT, LINK CONECTOR	1	1	1	

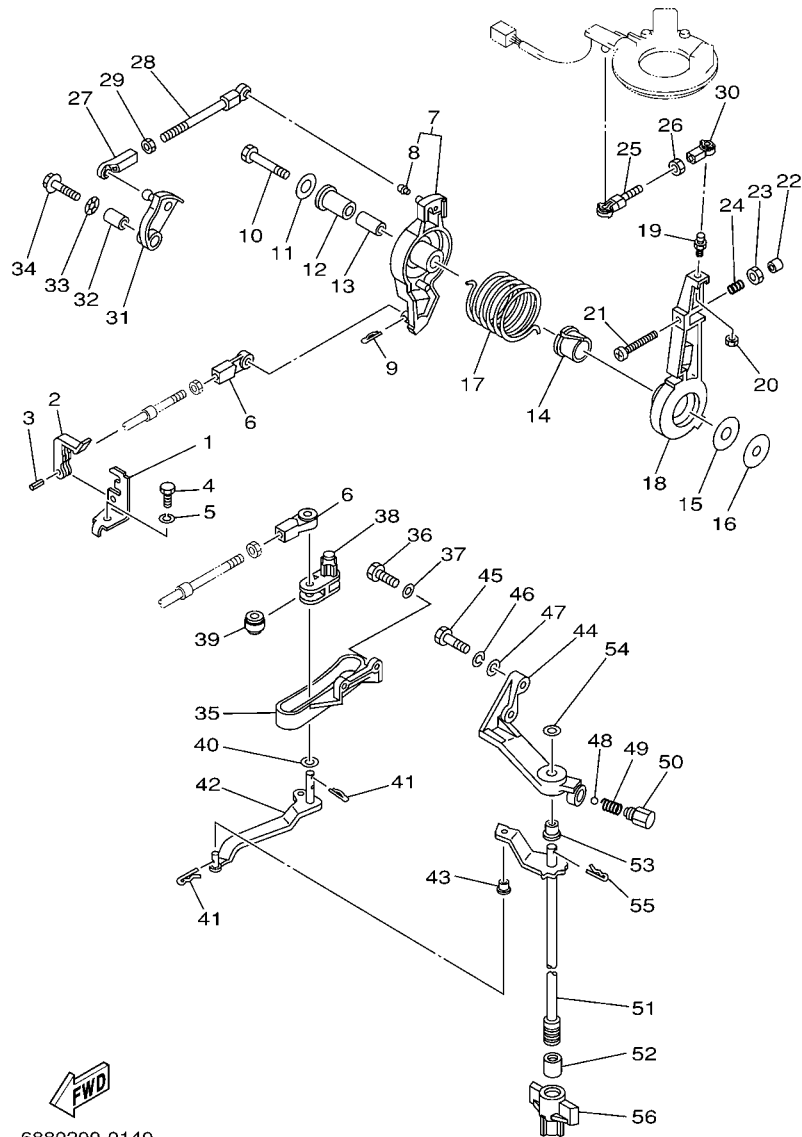

6880200-0140

FIG. 12 CONTROL

CONTROL

REF. NO.	PART NO. CODIGO Nº	DESCRIPTION DESCRIPCION	6456	6556	692F	REMARKS OBSERVACIONES
28	688-41211-01	LINK, ACCEL. ESLABON, ACELERADOR	1	1	1	
29	95380-05600	NUT TUERCA	1	1	1	
30	682-41237-00	JOINT, LINK CONECTOR	1	1	1	
31	692-41213-00	CAM, ACCEL. LEVA ACELERADOR	1	1		
	688-41213-00	CAM, ACCEL. LEVA ACELERADOR			1	
32	90387-06M17	COLLAR ESPACIADOR	1	1	1	
33	90206-10M04	WASHER, WAVE ARANDELA ONDULADA	1	1	1	
34	90119-06M24	BOLT, WITH WASHER TORNILLO CON ARANDELA	1	1	1	
35	688-44117-00-94	BRACKET SOPORTE	1	1	1	
36	97013-06020	BOLT PERNO	2	2	2	
37	92903-06600	WASHER, PLATE RONDANA SENCILLA	2	2	2	
38	688-44124-00	LINK, SHIFT ROD ESLABON	1	1	1	
39	688-44122-00	BUSHING, SHIFT ROD LEVER BUJE PALANCA VARILLA DE CAMBIO	1	1	1	
40	90202-07M07	WASHER, PLATE ARANDELA DE PLANA	1	1	1	
41	90468-18008	CLIP PRESILLA	3	3	3	
42	688-44121-02	LEVER, SHIFT ROD PALANCA VARILLA CAMBIOS	1	1	1	EXCEPT FOR MYS
	6H1-44121-00	LEVER, SHIFT ROD PALANCA VARILLA CAMBIOS			1	EXCEPT FOR MYS FOR MYS
43	90386-06M12	BUSH BUJE	1	1	1	EXCEPT FOR MYS EXCEPT FOR MYS
44	688-44118-01-94	BRACKET SOPORTE	1	1	1	
45	97013-08030	BOLT PERNO	2	2	2	
46	92903-08100	WASHER, SPRING RONDANA SENCILLA	2	2	2	
47	92903-08600	WASHER, PLATE RONDANA SENCILLA	2	2	2	
48	93501-04M02	BALL BOLA	1	1	1	
49	90501-12082	SPRING, COMPRESSION RESORTE DE COMPRESION	1	1	1	
50	648-42715-00	BUSHING BUJE	1	1	1	
51	692-44120-12	HANDLE GEAR SHIFT ASSY MANIJA DE CAMBIO COMPL	1	1	1	L(20.5") L(20.5")
	692-44120-00	HANDLE GEAR SHIFT ASSY MANIJA DE CAMBIO COMPL			1	L(20.5")-FOR MYS L(20.5")-FOR MYS

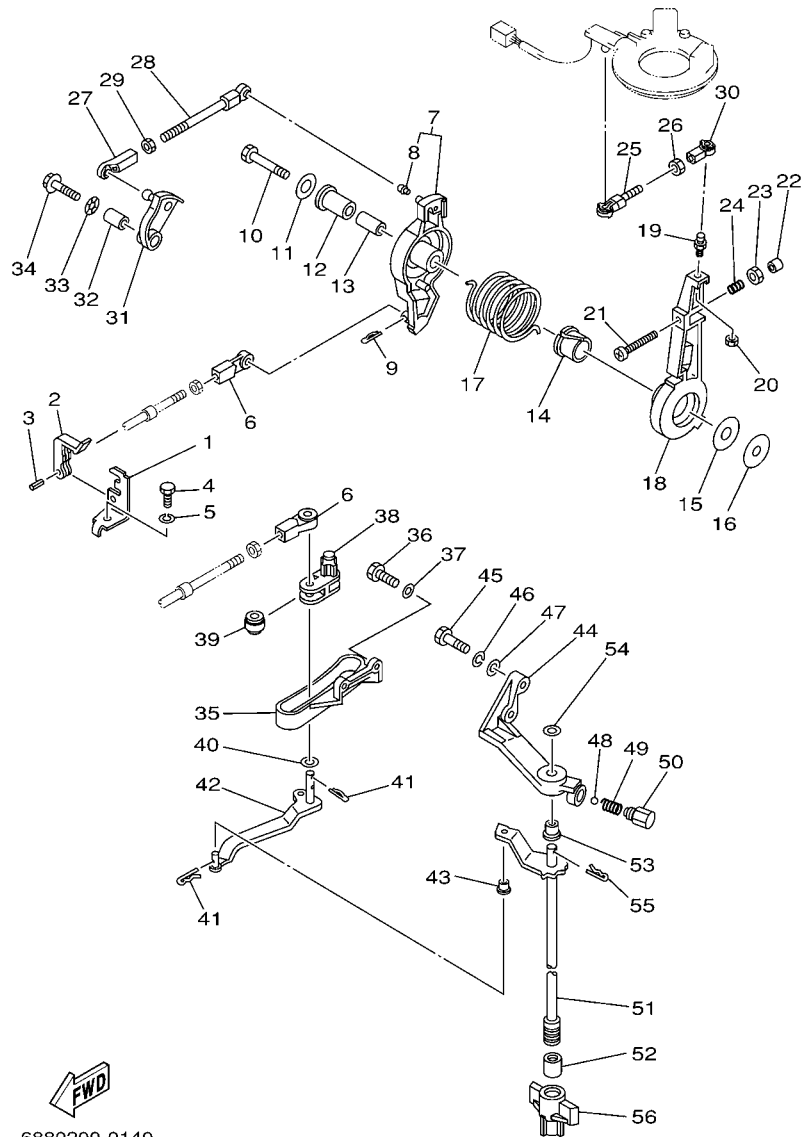

6880200-0140

FIG. 12 CONTROL

CONTROL

REF. NO.	PART NO. CODIGO Nº	DESCRIPTION DESCRIPCION	64S6	65S6	692F	REMARKS OBSERVACIONES
51	692-44120-42	HANDLE GEAR SHIFT ASSY MANIJA DE CAMBIO COMPL			1	Y(22.5") Y(22.5")
	692-44120-22	HANDLE GEAR SHIFT ASSY MANIJA DE CAMBIO COMPL		1	1	X(25.5") X(25.5")
52	696-44147-00	BOOT, SHIFT ROD HULE DE VARILLA	1	1	1	EXCEPT FOR MYS EXCEPT FOR MYS
53	90386-08006	BUSH BUJE	1	1	1	EXCEPT FOR MYS EXCEPT FOR MYS
	90386-07M58	BUSH BUJE			1	FOR MYS FOR MYS
54	92990-08200	WASHER, PLAIN ARANDELA PLANA	1	1	1	
55	90468-18008	CLIP PRESILLA	1	1	1	
56	697-43662-00	GUIDE, REVERSE ROD GUIA DE LA VARILLA DE REVERSE	1	1	1	EXCEPT FOR MYS EXCEPT FOR MYS

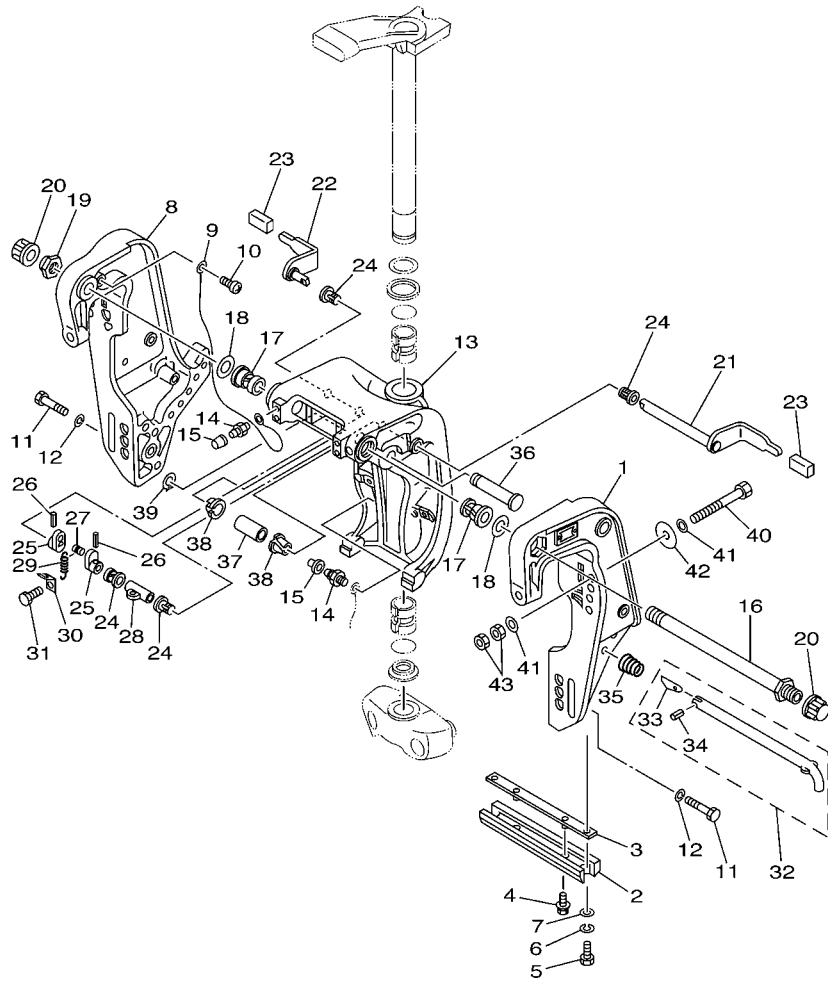

6882664-3120

FIG. 13 BRACKET 1

SOPORTE 1

REF. NO.	PART NO. CODIGO Nº	DESCRIPTION DESCRIPCION	64S6	65S6	692F	REMARKS OBSERVACIONES
1	688-43111-13-4D	BRACKET, CLAMP 1 SOPORTE DE LA ABRAZADERA 1	1	1	1	
2	6H1-45251-03	ANODE CATODE	1	1	1	
3	6H1-44526-00	PLATE PLACA 1	1	1	1	
4	90119-06M29	BOLT, WITH WASHER TORNILLO CON ARANDELA	2	2	2	
5	97095-06016	BOLT PERNO	2	2	2	
6	92995-06100	WASHER, SPRING ARANDELA	2	2	2	
7	92995-06600	WASHER ARANDELA	2	2	2	
8	688-43112-12-4D	BRACKET, CLAMP 2 SOPORTE DE LA ABRAZADERA 2	1	1	1	
9	6E5-82148-00	WIRE, LEAD 4 CABLE CONDUCTOR 4	1	1	1	
10	97880-06012	SCREW, PAN HEAD TORNILLO DE CABEZA CON PLANA	1	1	1	
11	97095-10045	BOLT PERNO	6	6	6	
12	92995-10100	WASHER ARANDELA	6	6	6	
13	6H1-43311-02-4D	BRACKET, SWIVEL 1 SOPORTE GIRATORIO 1	1	1	1	
14	93700-06M03	NIPPLE, GREASE BOQUILLA DE ENGRASAR	3	3	3	
15	663-45119-00	CAP, GREASE NIPPLE TAPA DE GRASERA	3	3	3	
16	688-43131-03	BOLT, CLAMP BRACKET TORNILLO DE ABRAZADERA DEL SOP	1	1	1	
17	90386-22M15	BUSH BUJE	2	2	2	
18	90201-22M67	WASHER, PLATE ARANDELA PLANA	2	2	2	
19	90185-22043	NUT, SELF-LOCKING TUERCA AUTOBLOCANTE	1	1	1	
20	6G5-43145-01	CAP, CLAMP BRACKET TAPA	2	2	2	
21	688-43181-10	LEVER, TILT STOP PALANCA TOPE INCLINACION	1	1	1	
22	688-43185-10	LEVER, TILT STOP PALANCA TOPE INCLINACION	1	1	1	
23	663-43318-00	COVER CUBIERTA	2	2	2	
24	90386-10M16	BUSH BUJE	4	4	4	
25	6G5-43148-00	COLLAR, DISTANCE COLLAR	2	2	2	
26	91690-30020	PIN, SPRING PASADOR DE RESORTE	2	2	2	
27	90249-06M19	PIN PASADOR	1	1	1	

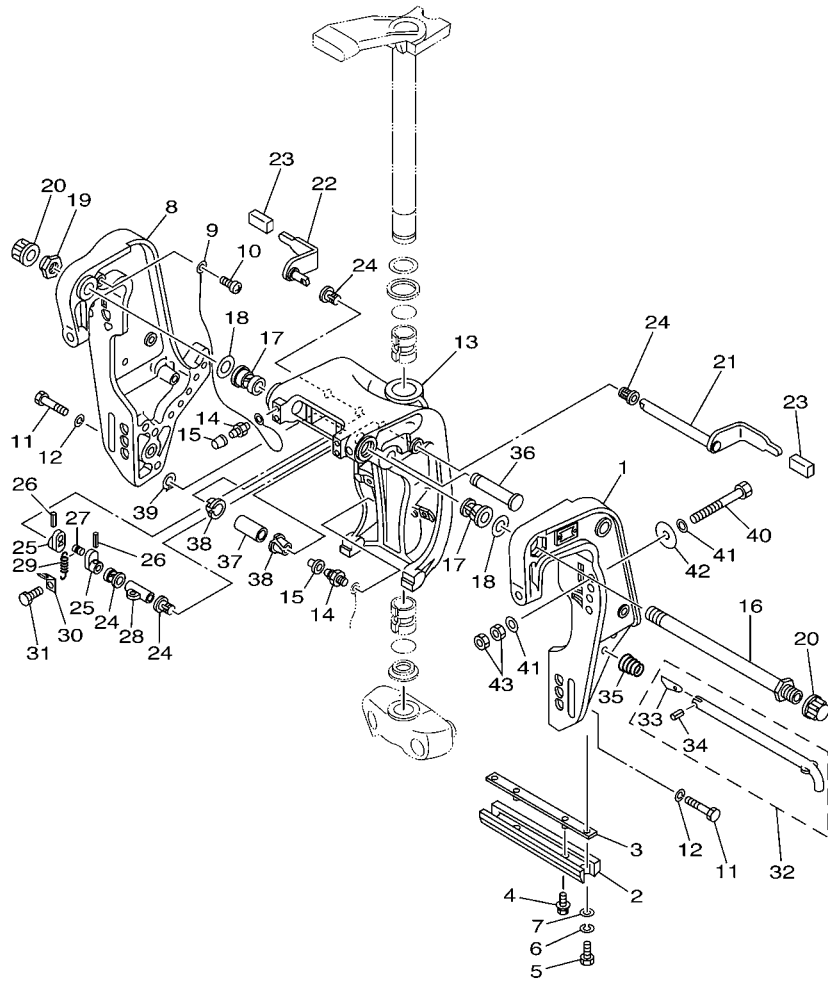

6882664-3120

FIG. 13 BRACKET 1

SOPORTE 1

REF. NO.	PART NO. CODIGO N°	DESCRIPTION DESCRIPCION	64S6	65S6	692F	REMARKS OBSERVACIONES
28	90387-10M02	COLLAR ESPACIADOR	1	1	1	
29	90506-14M24	SPRING, TENSION RESORTE DE TENSION	1	1	1	
30	6G5-43144-00	HOOK, SPRING GANCHO	1	1	1	
31	97095-06010	BOLT PERNO	1	1	1	
32	688-43160-01	TILT ROD ASSY VARILLA DE BASCULACION COMPL.	1	1	1	
33	688-43165-00	.PLATE, TILT LOCK .PLACA DE TOPE, VARILLA SEGURID	1	1	1	
34	91690-30012	.PIN, SPRING .PASADOR DE RESORTE	1	1	1	
35	90502-16M02	SPRING, CONICAL RESORTE CONICO	1	1	1	
36	6E5-43126-02	PIN, UPPER SHOCK MOUNT PASADOR DE AMORTIGUADOR SUPERI	1	1	1	
37	90386-18M21	BUSH BUJE	1	1	1	
38	90386-18M35	BUSH BUJE	2	2	2	
39	93410-18M02	CIRCLIP SEGURO	1	1	1	
40	90101-12M65	BOLT TORNILLO	4	4	4	
41	92995-12200	WASHER ARANDELA	8	8	8	
42	90201-12426	WASHER, PLATE ARANDELA PLANA	4	4	4	
43	95380-12600	NUT TUERCA	8	8	8	

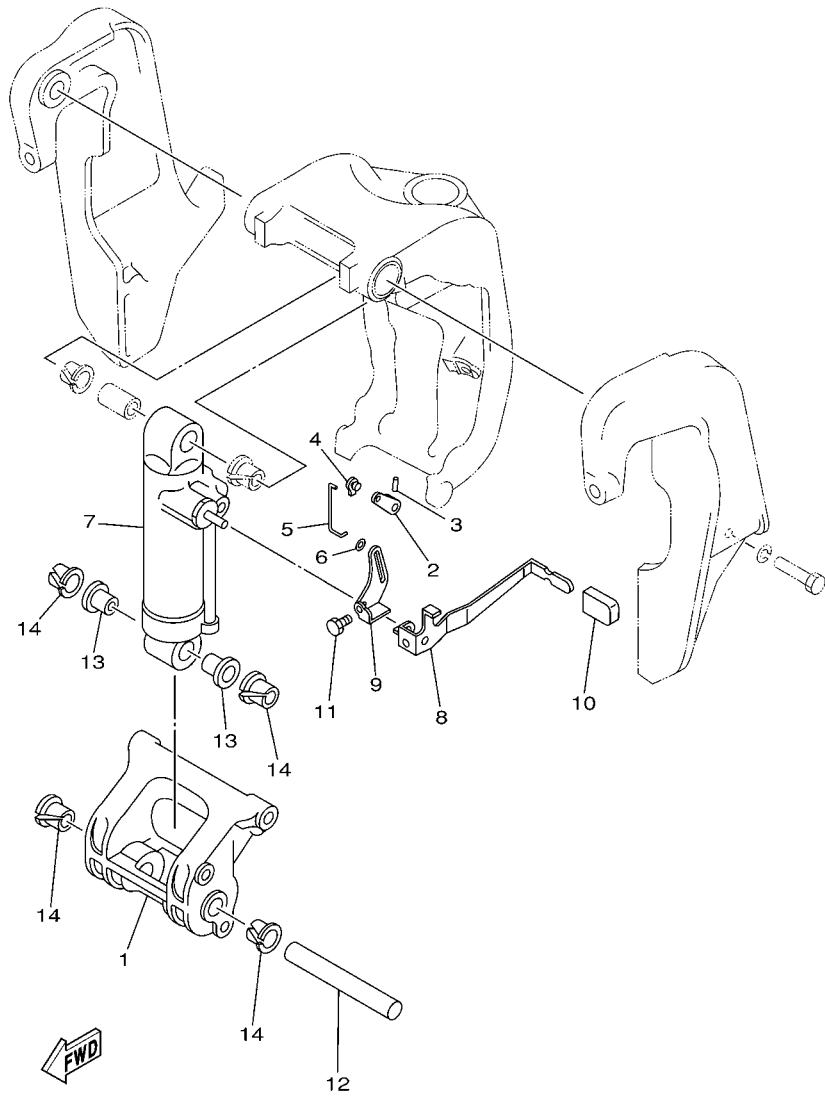

6H10010-0170

FIG. 14 BRACKET 2

SOPORTE 2

REF. NO.	PART NO. CODIGO Nº	DESCRIPTION DESCRIPCION	64S6	65S6	692F	REMARKS OBSERVACIONES
1	688-43128-01-4D	SPACER, CLAMP BRACKET ESPACIADOR ABRAZADERA SOPORTE	1	1	1	
2	688-43186-00	LEVER PALANCA	1	1	1	
3	91690-30020	PIN, SPRING PASADOR DE RESORTE	1	1	1	
4	6J8-41262-00	JOINT, CHOKE LEVER CONECTOR DE AHOGADOR	1	1	1	
5	688-43616-00	ROD, TILT LOCK VARILLA SEGURO DE INCLINACION	1	1	1	
6	90202-03M51	WASHER, PLATE ARANDELA DE PLANA	1	1	1	
7	688-43170-04-4D	SHOCK ABSORBER ASSY AMORTIGUADOR COMPL.	1	1	1	
8	688-43631-10	LEVER, TILT PALANCA DE INCLINACION	1	1	1	
9	688-43651-00	LEVER, REVERSE LOCK 1 PALANCA SEGURO DE RESERVA	1	1	1	
10	682-43318-01	COVER CUBIERTA	1	1	1	
11	97080-06010	BOLT PERNO	1	1	1	
12	688-43124-02	PIN, LOWER SHOCK MOUNT PASADOR DE AMORTIGUADOR INFERI	1	1	1	
13	90386-18M63	BUSH BUJE	2	2	2	
14	90386-18M35	BUSH BUJE	4	4	4	

FIG. 15 BRACKET 3

SOPORTE 3

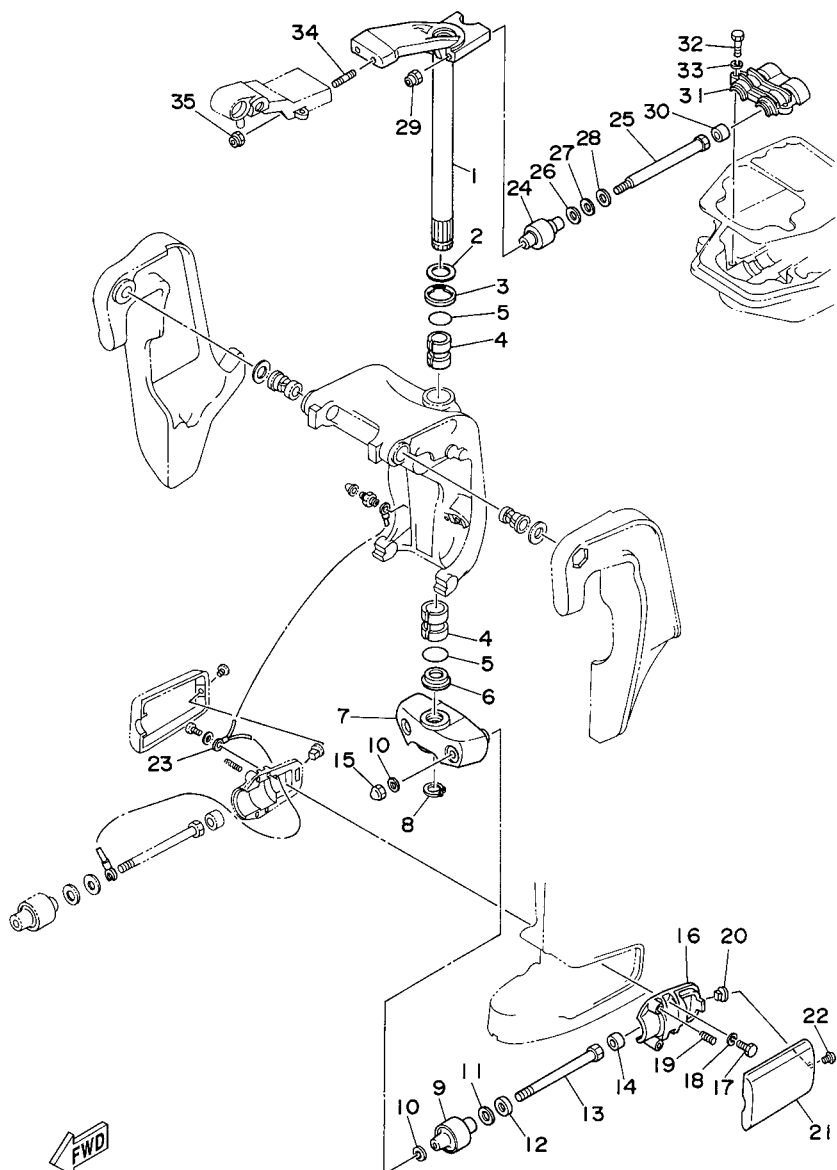

6920100-4160

REF. NO.	PART NO. CODIGO Nº	DESCRIPTION DESCRIPCION	6456	6556	692F	REMARKS OBSERVACIONES
1	692-42510-00-4D	STEERING BRACKET ASSY SOPORTE DIRECCION COMPL.	1	1	1	
2	90201-30M00	WASHER, PLATE ARANDELA PLANA	1	1	1	
3	90386-30M78	BUSH BUJE	1	1	1	
4	90386-30M77	BUSH BUJE	2	2	2	
5	93210-29M94	O-RING ANILLO O	2	2	2	
6	90386-30M60	BUSH BUJE	1	1	1	
7	692-44551-00-4D	HOUSING, LOWER MOUNT RUBBER CAJA AMORTIGUADOR INFERIOR HU	1	1	1	
8	93410-28M06	CIRCLIP SEGURO	1	1	1	
9	687-44555-00-94	MOUNT DAMPER, LOWER SIDE AMORTIGUADOR DE HULE LADO INFE	2	2	2	
10	90201-12M16	WASHER, PLATE ARANDELA PLANA	4	4	4	
11	90202-25M04	WASHER, PLATE ARANDELA DE PLANA	2	2	2	
12	90201-13M19	WASHER, PLATE ARANDELA PLANA	2	2	2	
13	90109-12261	BOLT PERNO	2	2	2	
14	663-44575-00	DAMPER, LOWER MOUNT RUBBER AMORTIGUADOR INFERIOR	2	2	2	
15	95380-12800	NUT, CROWN TUERCA	2	2	2	
16	687-44552-02-94	HOUSING, LOWER MOUNT RUBBER CAJA AMORTIGUADOR INFERIOR HU	2	2	2	
17	97075-08025	BOLT PERNO	4	4	4	
18	92995-08100	WASHER ARANDELA	4	4	4	
19	90501-14M08	SPRING, COMPRESSION RESORTE DE COMPRESION	4	4	4	
20	90179-06066	NUT TUERCA	2	2	2	
21	663-44553-01-4D	COVER, LOWER MOUNT CUBIERTA, AMORTIGUADOR INFERIOR	2	2	2	
22	97885-06016	SCREW, PAN HEAD TORNILLO A MUESCA	2	2	2	
23	688-82127-02	WIRE, LEAD 2 CABLE CONDUCTOR 2	1	1	1	
24	688-44514-00-94	MOUNT DAMPER, UPPER SIDE AMORTIGUADOR LADO SUPERIOR	2	2	2	
25	90101-10M49	BOLT TORNILLO	2	2	2	
26	90201-20M21	WASHER, PLATE ARANDELA PLANA	2	2	2	
27	90202-20M06	WASHER, PLATE ARANDELA DE PLANA	2	2	2	

FIG. 15 BRACKET 3

SOPORTE 3

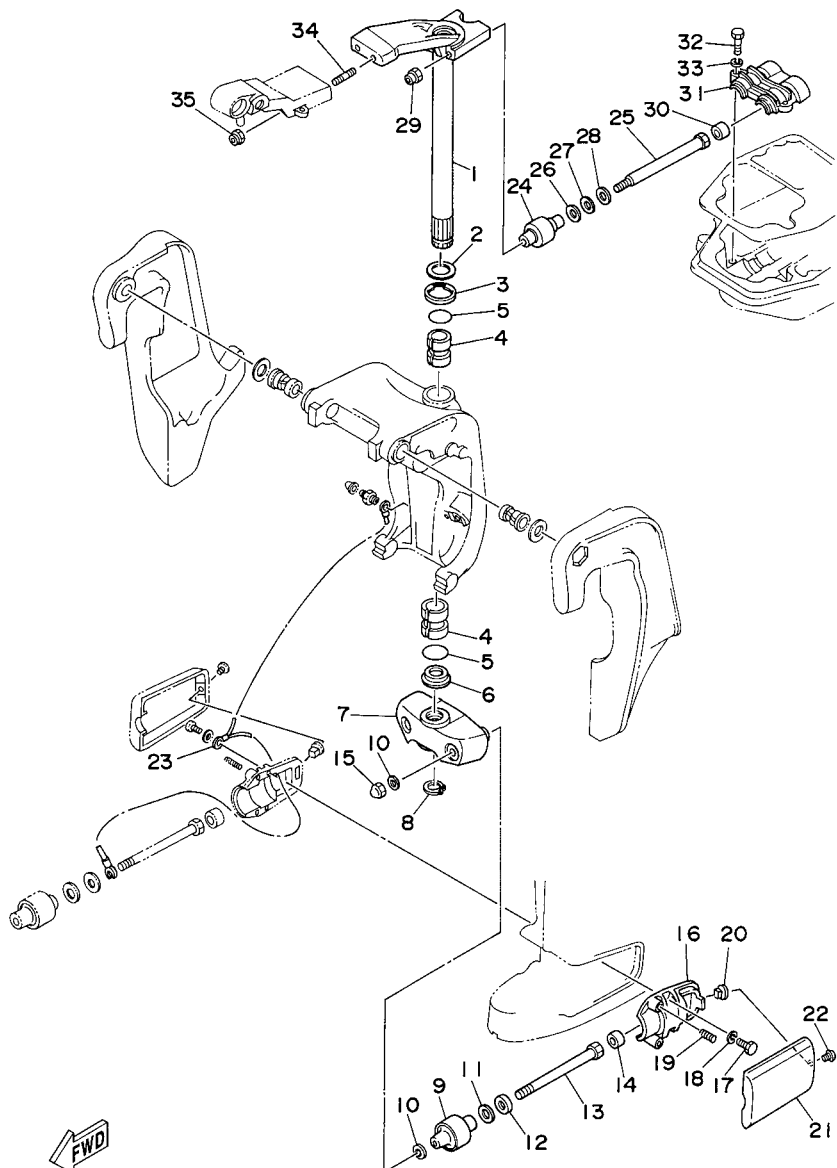

6920100-4160

REF. NO.	PART NO. CODIGO Nº	DESCRIPTION DESCRIPCION	64S6	65S6	692F	REMARKS OBSERVACIONES
28	90201-11M22	WASHER, PLATE ARANDELA PLANA	2	2	2	
29	90185-10051	NUT, SELF-LOCKING TUERCA AUTOBLOCANTE	2	2	2	
30	663-44575-00	DAMPER, LOWER MOUNT RUBBER AMORTIGUADOR INFERIOR	2	2	2	
31	688-44511-00-94	COVER, UPPER MOUNT CUBIERTA AMORTIGUADOR SUPERIOR	1	1	1	
32	97075-08035	BOLT PERNO	3	3	3	
33	92995-08100	WASHER ARANDELA	3	3	3	
34	90116-10M28	BOLT, STUD ESPARRAGO	2	2	2	
35	90185-10051	NUT, SELF-LOCKING TUERCA AUTOBLOCANTE	2	2	2	

FIG. 16 UPPER CASING

FUNDA SUPERIOR

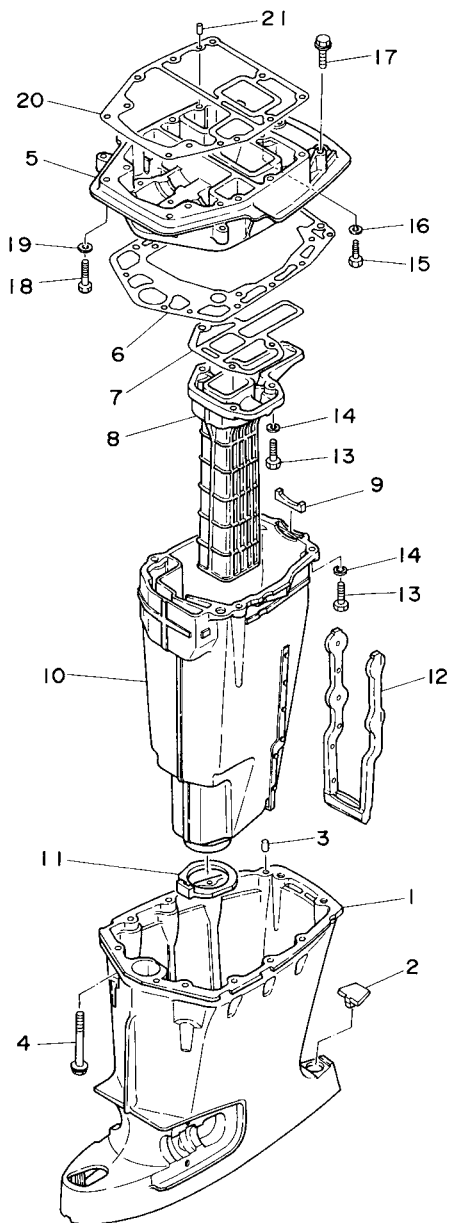
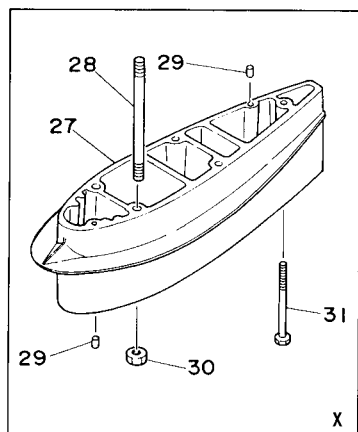
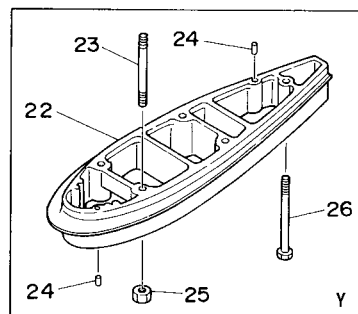

6925200-4160

REF. NO.	PART NO. CODIGO Nº	DESCRIPTION DESCRIPCION	6456	6556	692F	REMARKS OBSERVACIONES
1	688-45111-04-4D	CASING, UPPER CAJA SUPERIOR	1	1	1	
2	663-45155-10	CAP TAPA	1	1	1	
3	93606-12019	PIN, DOWEL PASADOR DE CLAVIJA	2	2	2	
4	90119-08M80	BOLT, WITH WASHER TORNILLO CON ARANDELA	8	8	8	
5	688-41137-03-94	GUIDE, EXHAUST GUIA DE ESCAPE	1	1	1	
6	688-45114-A1	GASKET, UPPER CASING EMPAQUE	1	1	1	
7	688-41134-A0	GASKET, EXHAUST MANIFOLD EMPAQUE	1	1	1	
8	688-41131-00-5B 688-41131-10-5B	MANIFOLD, EXT. 1 TUBO MULTIPLE DE ESCAPE MANIFOLD, EXT. 1 TUBO MULTIPLE DE ESCAPE	1	1	1	FOR NME FOR NME
9	688-41133-00	GASKET, EXHAUST MANIFOLD 1 EMPAQUE ESCAPE MULTIPLE	1	1	1	
10	688-14711-01-5B 688-14711-10-5B	MUFFLER 1 SILENCIADOR 1 MUFFLER 1 SILENCIADOR 1	1	1	1	FOR NME FOR NME
11	688-45123-00	GASKET, MUFFLER EMPAQUE SILENCIADOR	1	1	1	
12	663-14737-10	DAMPER, MUFFLER AMORTIGUADOR DE SILENCIADOR	1	1	1	
13	97075-08030	BOLT PERNO	7	7	7	
14	92995-08100	WASHER ARANDELA	7	7	7	
15	97075-08025	BOLT PERNO	1	1	1	
16	92995-08100	WASHER ARANDELA	1	1	1	
17	90119-08M79	BOLT, WITH WASHER TORNILLO CON ARANDELA	2	2	2	
18	97075-08035	BOLT PERNO	2	2	2	
19	92995-08100	WASHER ARANDELA	2	2	2	
20	688-45113-A0	GASKET, UPPER CASING EMPAQUE	1	1	1	
21	93606-12019	PIN, DOWEL PASADOR DE CLAVIJA	2	2	2	
22	696-45211-01-4D	EXTENSION EXTENSION			1	Y(22.5") Y(22.5")
23	90116-10M31	BOLT, STUD ESPARRAGO			4	Y(22.5") Y(22.5")
24	93606-12019	PIN, DOWEL PASADOR DE CLAVIJA			4	Y(22.5") Y(22.5")
25	95380-10600	NUT TUERCA			4	Y(22.5") Y(22.5")

FIG. 16 UPPER CASING

FUNDA SUPERIOR

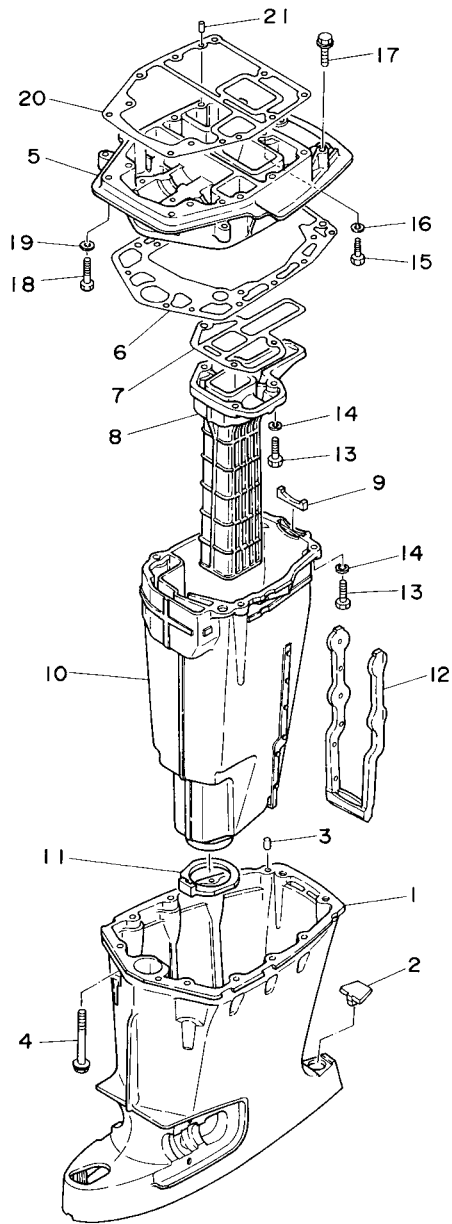
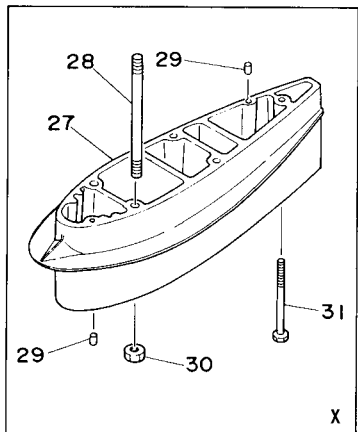
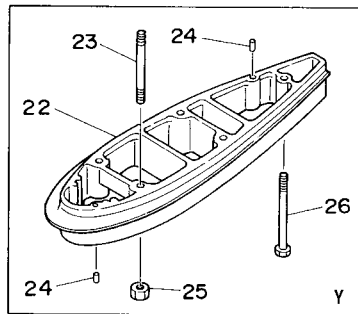

REF. NO.	PART NO. CODIGO Nº	DESCRIPTION DESCRIPCION	64S6	65S6	692F	REMARKS OBSERVACIONES
26	90119-08M85	BOLT, WITH WASHER TORNILLO CON ARANDELA			1	Y(22.5") Y(22.5")
27	688-45211-01-4D	EXTENSION EXTENSION		1	1	X(25.5") X(25.5")
28	90116-10M05	BOLT, STUD ESPARRAGO		4	4	X(25.5") X(25.5")
29	93606-12019	PIN, DOWEL PASADOR DE CLAVIJA		4	4	X(25.5") X(25.5")
30	95380-10600	NUT TUERCA		4	4	X(25.5") X(25.5")
31	90119-08M86	BOLT, WITH WASHER TORNILLO CON ARANDELA			1	X(25.5") X(25.5")

6925200-4160

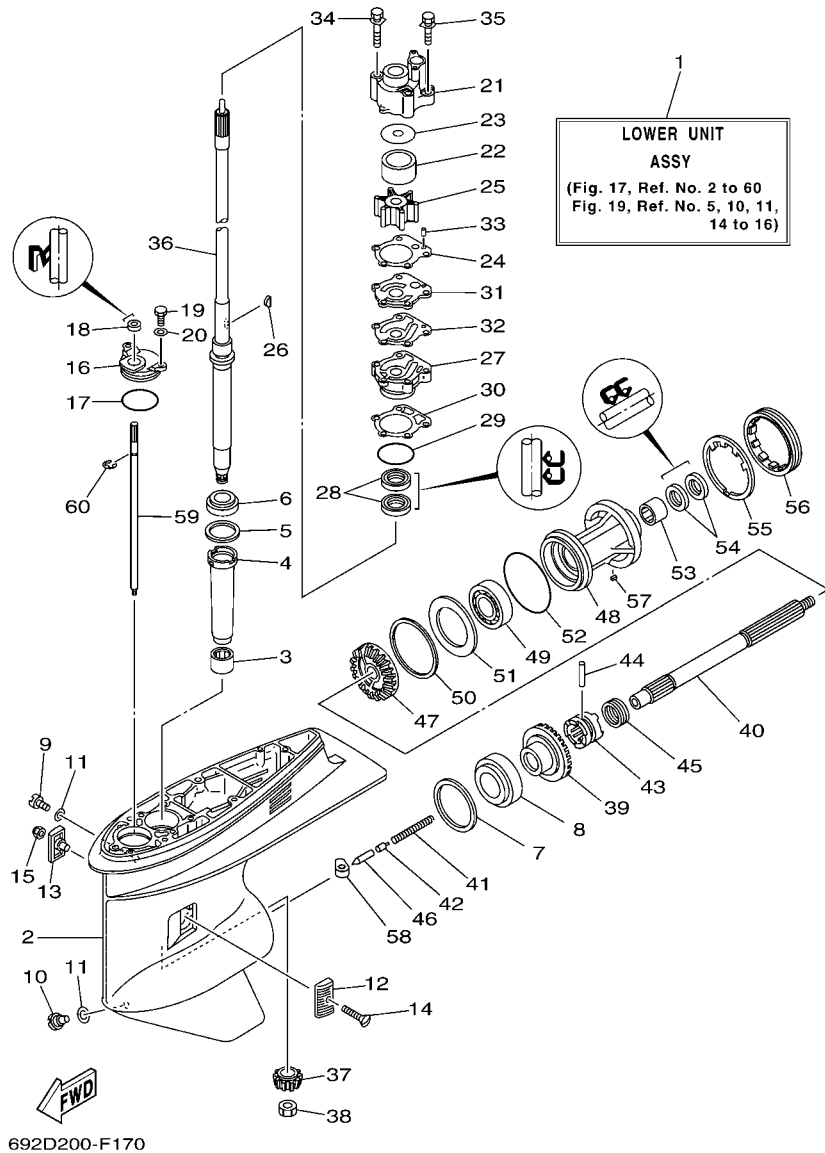
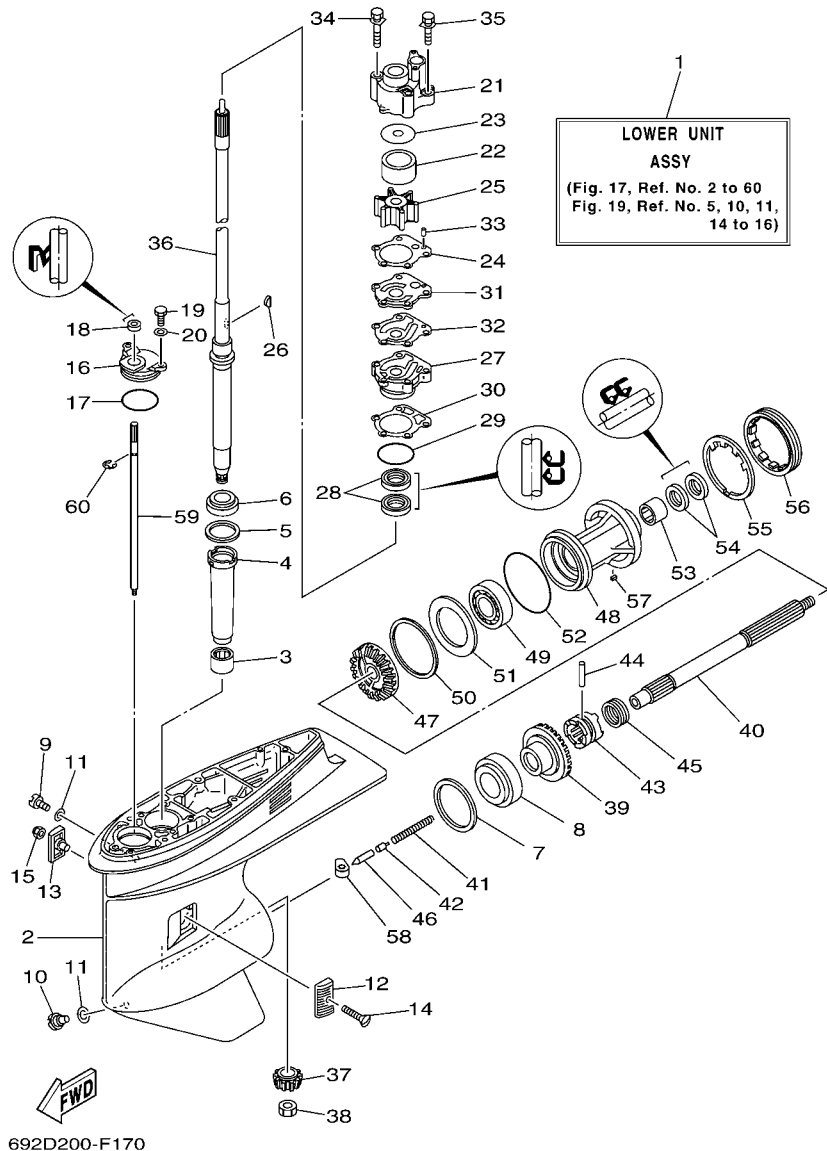

FIG. 17 LOWER CASING & DRIVE 1 IMPULSOR E INFERIOR 1

REF. NO.	PART NO. CODIGO Nº	DESCRIPTION DESCRIPCION	64S6	65S6	692F	REMARKS OBSERVACIONES
1	692-45300-62-4D	LOWER UNIT ASSY CONJUNTO UNIDAD INFERIOR	1	1		L(20.5") L(20.5")
	692-45300-14-4D	LOWER UNIT ASSY CONJUNTO UNIDAD INFERIOR			1	L(20.5") L(20.5")
	692-45300-34-4D	LOWER UNIT ASSY CONJUNTO UNIDAD INFERIOR			1	Y(22.5") Y(22.5")
	692-45300-80-4D	LOWER UNIT ASSY CONJUNTO UNIDAD INFERIOR		1		X(25.5") X(25.5")
	692-45300-24-4D	LOWER UNIT ASSY CONJUNTO UNIDAD INFERIOR			1	X(25.5") X(25.5")
2	688-45311-06-4D	CASING, LOWER FUNDA INFERIOR	1	1	1	
3	93315-325V1	BEARING COJINETE DE RODILLOS	1	1	1	
4	688-45536-01	SLEEVE, DRIVE SHAFT CAMISA EJE DE MANDO	1	1	1	
5	688-45587-01	SHIM (T:0.10MM) LAINA (T:0.10MM)	1	1	1	UR UR
	688-45587-10	SHIM (T:0.12MM) LAINA (T:0.12MM)	1	1	1	UR UR
	688-45587-20	SHIM (T:0.15MM) LAINA (T:0.15MM)	1	1	1	UR UR
	688-45587-30	SHIM (T:0.18MM) LAINA (T:0.18MM)	1	1	1	UR UR
	688-45587-40	SHIM (T:0.30MM) LAINA (T:0.30MM)	1	1	1	UR UR
	688-45587-50	SHIM (T:0.40MM) LAINA (T:0.40MM)	1	1	1	UR UR
	688-45587-60	SHIM (T:0.50MM) LAINA (T:0.50MM)	1	1	1	UR UR
6	93332-000U3	BEARING COJINETE	1	1	1	
7	688-45567-01	SHIM (T:0.10MM) LAINA (T:0.10MM)	1	1	1	UR UR
	688-45567-10	SHIM (T:0.12MM) LAINA (T:0.12MM)	1	1	1	UR UR
	688-45567-20	SHIM (T:0.15MM) LAINA (T:0.15MM)	1	1	1	UR UR
	688-45567-30	SHIM (T:0.18MM) LAINA (T:0.18MM)	1	1	1	UR UR
	688-45567-40	SHIM (T:0.30MM) LAINA (T:0.30MM)	1	1	1	UR UR
	688-45567-50	SHIM (T:0.40MM) LAINA (T:0.40MM)	1	1	1	UR UR
	688-45567-60	SHIM (T:0.50MM) LAINA (T:0.50MM)	1	1	1	UR UR
8	93332-000W7	BEARING COJINETE	1	1	1	
9	90340-08002	PLUG, STRAIGHT SCREW TORNILLO, DE DRENAJE	1	1	1	
10	688-45341-10	PLUG, DRAIN TAPON, DREN	1	1	1	
11	90430-08020	GASKET JUNTA	2	2	2	



692D200-F170

FIG. 17 LOWER CASING & DRIVE 1 IMPULSOR E INFERIOR 1

REF. NO.	PART NO. CODIGO Nº	DESCRIPTION DESCRIPCION	64S6	65S6	692F	REMARKS OBSERVACIONES
12	6H1-45214-00	COVER, WATER INLET 1 CUBIERTA ENTRADA AGUA 1	1	1	1	
13	6H1-45215-00	COVER, WATER INLET 2 CUBIERTA ENTRADA AGUA 2	1	1	1	
14	90151-05M00	SCREW, COUNTERSUNK TORNILLO EMBUTIDO	1	1	1	
15	90185-05002	NUT, SELF-LOCKING TUERCA AUTOBLOCANTE	1	1	1	
16	688-45321-00	PLATE PLACA	1	1	1	
17	93210-49046	O-RING ANILLO O	1	1	1	
18	93106-09014	OIL SEAL SELLO ACEITE	1	1	1	
19	97095-06016	BOLT PERNO	2	2	2	
20	92995-06600	WASHER ARANDELA	2	2	2	
21	688-44311-01	HOUSING, WATER PUMP CAJA BOMBA DE AGUA	1	1	1	
22	688-44322-41	INSERT, CARTRIDGE CARTUCHO	1	1	1	FOR CHROMATE FOR CHROMATE
23	688-44321-41	INNER PLATE, CARTRIDGE PLACA INTERIOR CARTUCHO	1	1	1	FOR CHROMATE FOR CHROMATE
24	688-44315-A0	GASKET, WATER PUMP EMPAQUE	1	1	1	
25	688-44352-03	IMPELLER IMPULSOR	1	1	1	
26	90280-04M04	KEY, WOODRUFF CUNA WOODRUFF	1	1	1	
27	688-44341-01-94	HOUSING, WATER PUMP CAJA BOMBA DE AGUA	1	1	1	
28	93101-25M03	OIL SEAL SELLO ACEITE	2	2	2	
29	93210-46044	O-RING ANILLO O	1	1	1	
30	688-44316-A0	GASKET, WATER PUMP EMPAQUE	1	1	1	
31	688-44323-40	OUTER PLATE, CARTRIDGE PLACA EXTERIOR DEL CARTUCHO	1	1	1	FOR CHROMATE FOR CHROMATE
32	688-44324-A0	GASKET, CARTRIDGE EMPAQUE	1	1	1	
33	93604-10M03	PIN, DOWEL PASADOR DE CLAVIJA	2	2	2	
34	90119-08M16	BOLT, WITH WASHER TORNILLO CON ARANDELA	2	2	2	
35	90119-08M13	BOLT, WITH WASHER TORNILLO CON ARANDELA	2	2	2	
36	688-45501-11	DRIVE SHAFT COMPL. EJE DE MANDO COMPL.	1	1	1	L(20.5")
	692-45501-21	DRIVE SHAFT COMPL. EJE DE MANDO COMPL.			1	L(20.5") Y(22.5")
	688-45501-22	DRIVE SHAFT COMPL. EJE DE MANDO COMPL.		1	1	X(25.5") X(25.5")

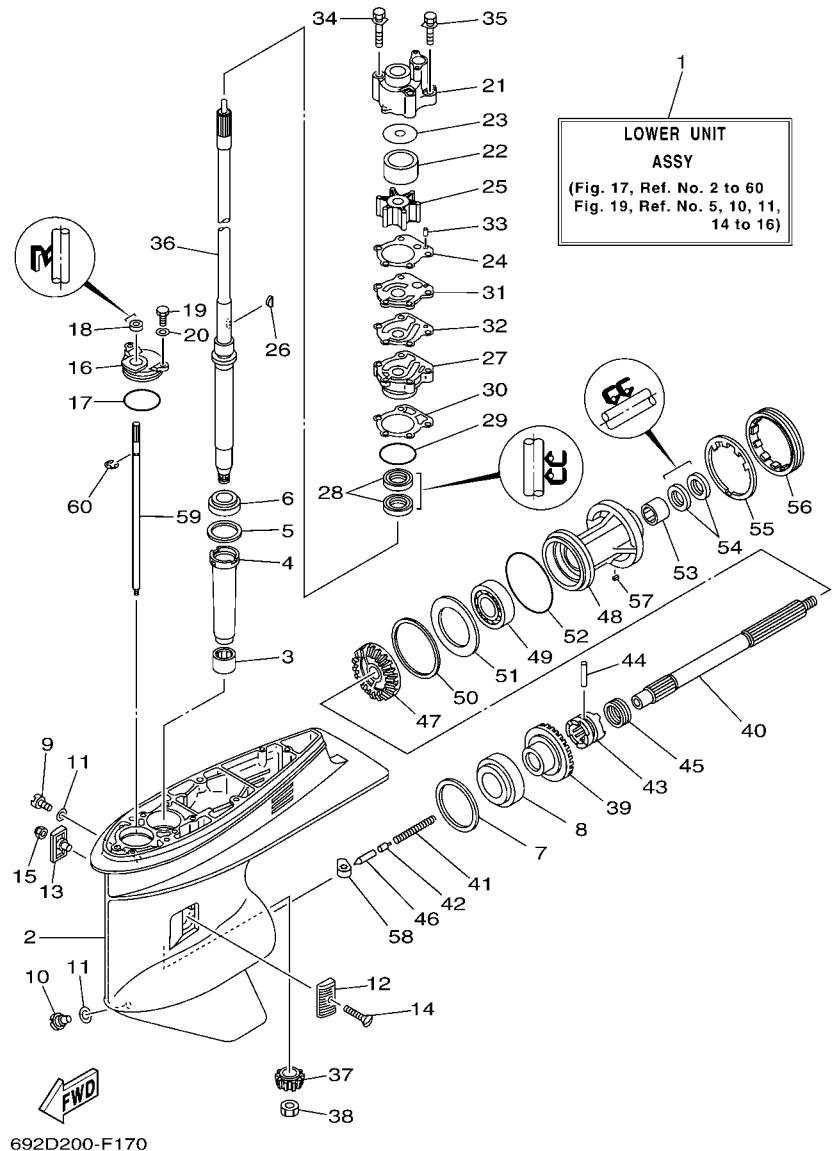

692D200-F170

FIG. 17 LOWER CASING & DRIVE 1 IMPULSOR E INFERIOR 1

REF. NO.	PART NO. CODIGO Nº	DESCRIPTION DESCRIPCION	64S6	65S6	692F	REMARKS OBSERVACIONES
37	6K5-45551-00	PINION (12T) PINON (12T)	1	1		
	688-45551-01	PINION (13T) PINON (13T)			1	
38	90170-16M01	NUT TUERCA	1	1	1	
39	6K5-45560-00	GEAR 1 (28T) ENGRANAJE 1 (28T)	1	1		
	688-45560-00	GEAR 1 (26T) ENGRANAJE 1 (26T)			1	
40	688-45611-00	SHAFT, PROPELLER EJE PROPUSOR	1	1	1	
41	90501-16233	SPRING, COMPRESSION RESORTE DE COMPRESION	1	1	1	
42	688-45634-00	SLIDE, SHIFT DESLIZADOR, CAMBIO	1	1	1	
43	688-45631-01	CLUTCH, DOG EMBRAGUE DE GARRA	1	1	1	
44	90250-07M02	PIN, STRAIGHT PASADOR CILINDRICO	1	1	1	
45	688-45633-00	RING, CROSS PIN ANILLO DE PASADOR	1	1	1	
46	688-45635-00	PLUNGER, SHIFT EMBOLO DE CAMBIO	1	1	1	
47	6K5-45571-00	GEAR 2 (28T) ENGRANAJE 2 (28T)	1	1		
	688-45571-01	GEAR 2 (26T) ENGRANAJE 2 (26T)			1	
48	688-45331-00-94	HOUSING, BEARING CAJA DE COJINETE	1	1	1	
49	93306-207U0	BEARING COJINETE	1	1	1	
50	688-45577-01	SHIM (T:0.10MM) LAINA (T:0.10MM)	1	1	1	UR
	688-45577-10	SHIM (T:0.12MM) LAINA (:0.12MM)	1	1	1	UR
	688-45577-20	SHIM (T:0.15MM) LAINA (T:0.15MM)	1	1	1	UR
	688-45577-30	SHIM (T:0.18MM) LAINA (T:0.18MM)	1	1	1	UR
	688-45577-40	SHIM (T:0.30MM) LAINA (T:0.30MM)	1	1	1	UR
	688-45577-50	SHIM (T:0.40MM) LAINA (T:0.40MM)	1	1	1	UR
	688-45577-60	SHIM (T:0.50MM) LAINA (T:0.50MM)	1	1	1	UR
51	688-45576-00	WASHER, THRUST ARANDELA DE EMPUJE AXIAL	1	1	1	
52	93210-85M97	O-RING ANILLO O	1	1	1	
53	93317-325U0	BEARING COJINETE	1	1	1	
54	93101-25M03	OIL SEAL SELLO ACEITE	2	2	2	

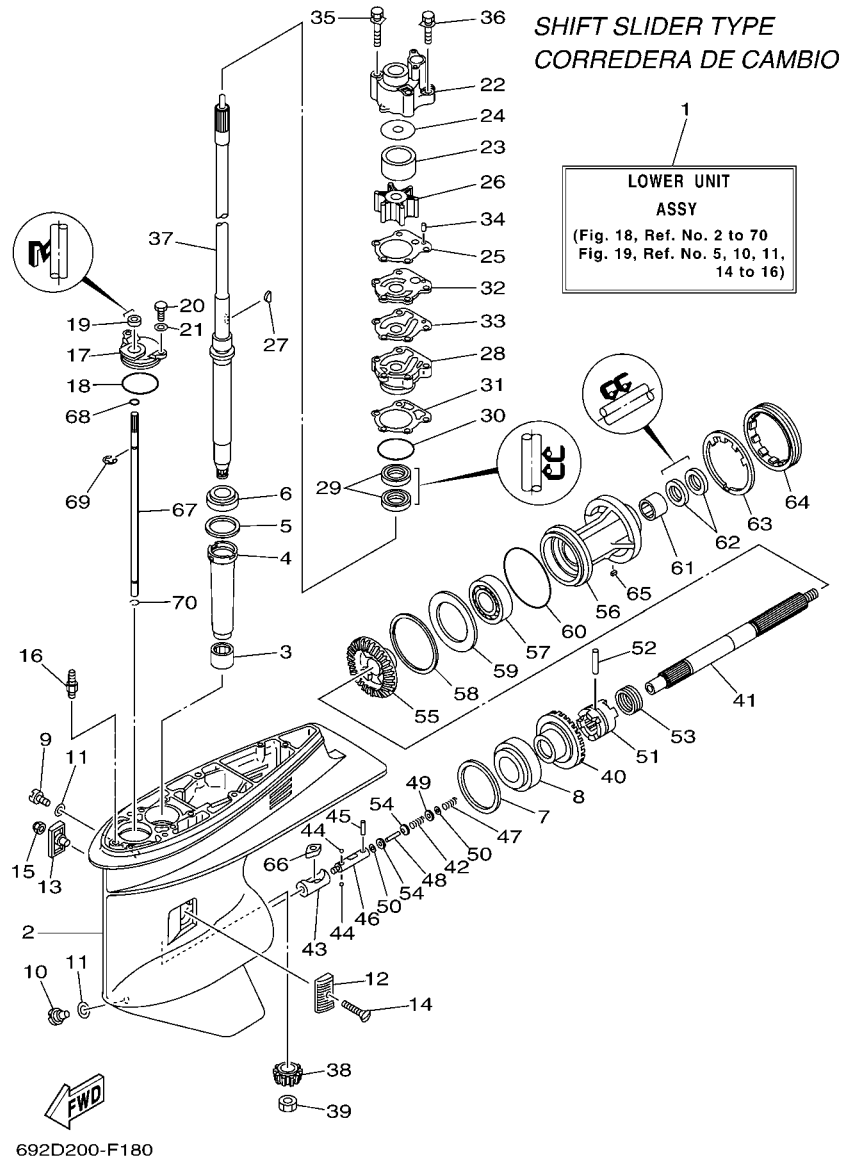

692D200-F180

SHIFT SLIDER TYPE
CORREDERA DE CAMBIO

LOWER UNIT
ASSY

(Fig. 18, Ref. No. 2 to 70
Fig. 19, Ref. No. 5, 10, 11,
14 to 16)

FIG. 18 LOWER CASING & DRIVE 2 IMPULSOR E INFERIOR 2

REF. NO.	PART NO. CODIGO Nº	DESCRIPTION DESCRIPCION	64S6	65S6	692F	REMARKS OBSERVACIONES
1	692-45300-40-4D	LOWER UNIT ASSY CONJUNTO UNIDAD INFERIOR			1	L(20.5")-FOR MYS L(20.5")-FOR MYS
2	6H1-45301-03-4D	CASING, LOWER FUNDA INFERIOR COMPLETA			1	
3	93315-325V1	BEARING COJINETE DE RODILLOS			1	
4	688-45536-01	SLEEVE, DRIVE SHAFT CAMISA EJE DE MANDO			1	
5	688-45587-01	SHIM (T:0.10MM) LAINA (T:0.10MM)			1	UR UR
688-45587-10	SHIM (T:0.12MM) LAINA (T:0.12MM)			1	UR UR	
688-45587-20	SHIM (T:0.15MM) LAINA (T:0.15MM)			1	UR UR	
688-45587-30	SHIM (T:0.18MM) LAINA (T:0.18MM)			1	UR UR	
688-45587-40	SHIM (T:0.30MM) LAINA (T:0.30MM)			1	UR UR	
688-45587-50	SHIM (T:0.40MM) LAINA (T:0.40MM)			1	UR UR	
688-45587-60	SHIM (T:0.50MM) LAINA (T:0.50MM)			1	UR UR	
6	93332-000U3	BEARING COJINETE			1	
7	688-45567-01	SHIM (T:0.10MM) LAINA (T:0.10MM)			1	UR UR
688-45567-10	SHIM (T:0.12MM) LAINA (T:0.12MM)			1	UR UR	
688-45567-20	SHIM (T:0.15MM) LAINA (T:0.15MM)			1	UR UR	
688-45567-30	SHIM (T:0.18MM) LAINA (T:0.18MM)			1	UR UR	
688-45567-40	SHIM (T:0.30MM) LAINA (T:0.30MM)			1	UR UR	
688-45567-50	SHIM (T:0.40MM) LAINA (T:0.40MM)			1	UR UR	
688-45567-60	SHIM (T:0.50MM) LAINA (T:0.50MM)			1	UR UR	
8	93332-000W7	BEARING COJINETE			1	
9	90340-08002	PLUG, STRAIGHT SCREW TORNILLO, DE DRENAJE			1	
10	688-45341-10	PLUG, DRAIN TAPON, DREN			1	
11	90430-08020	GASKET JUNTA			2	
12	6H1-45214-00	COVER, WATER INLET 1 CUBIERTA ENTRADA AGUA 1			1	
13	6H1-45215-00	COVER, WATER INLET 2 CUBIERTA ENTRADA AGUA 2			1	
14	90151-05M00	SCREW, COUNTERSUNK TORNILLO EMBUTIDO			1	
15	90185-05002	NUT, SELF-LOCKING TUERCA AUTOBLOCANTE			1	

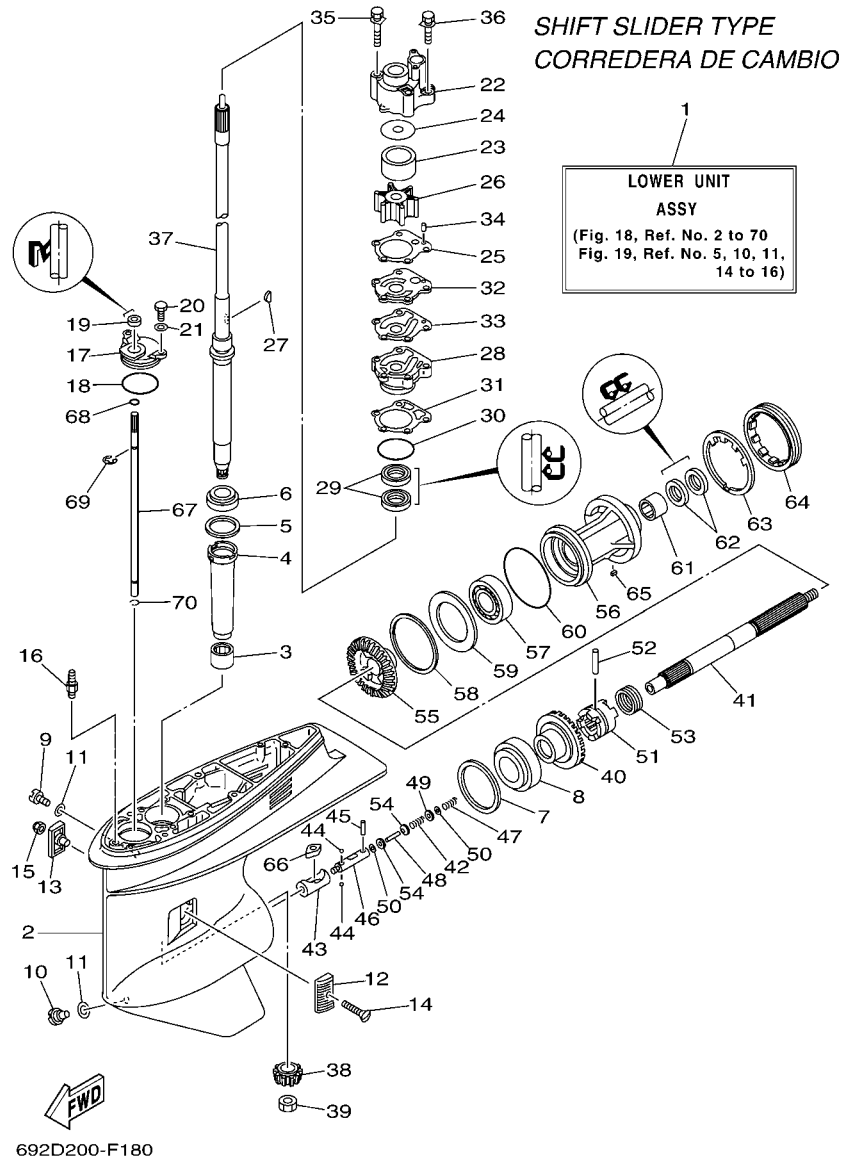

FIG. 18 LOWER CASING & DRIVE 2 IMPULSOR E INFERIOR 2

REF. NO.	PART NO. CODIGO Nº	DESCRIPTION DESCRIPCION	64S6	65S6	692F	REMARKS OBSERVACIONES
16	6J8-45378-00	NIPPLE, HOSE NIPLE MANGUERA			1	
17	688-45321-00	PLATE PLACA			1	
18	93210-49046	O-RING ANILLO O			1	
19	93106-09014	OIL SEAL SELLO ACEITE			1	
20	97095-06016	BOLT PERNO			2	
21	92995-06600	WASHER ARANDELA			2	
22	688-44311-01	HOUSING, WATER PUMP CAJA BOMBA DE AGUA			1	
23	688-44322-41	INSERT, CARTRIDGE CARTUCHO			1	FOR CHROMATE FOR CHROMATE
24	688-44321-41	INNER PLATE, CARTRIDGE PLACA INTERIOR CARTUCHO			1	FOR CHROMATE FOR CHROMATE
25	688-44315-A0	GASKET, WATER PUMP EMPAQUE			1	
26	688-44352-03	IMPELLER IMPULSOR			1	
27	90280-04M04	KEY, WOODRUFF CUNA WOODRUFF			1	
28	688-44341-01-94	HOUSING, WATER PUMP CAJA BOMBA DE AGUA			1	
29	93101-25M03	OIL SEAL SELLO ACEITE			2	
30	93210-46044	O-RING ANILLO O			1	
31	688-44316-A0	GASKET, WATER PUMP EMPAQUE			1	
32	688-44323-40	OUTER PLATE, CARTRIDGE PLACA EXTERIOR DEL CARTUCHO			1	FOR CHROMATE FOR CHROMATE
33	688-44324-A0	GASKET, CARTRIDGE EMPAQUE			1	
34	93604-10M03	PIN, DOWEL PASADOR DE CLAVIJA			2	
35	90119-08M16	BOLT, WITH WASHER TORNILLO CON ARANDELA			2	
36	90119-08M13	BOLT, WITH WASHER TORNILLO CON ARANDELA			2	
37	688-45501-11	DRIVE SHAFT COMP. EJE DE MANDO COMPL.			1	L(20.5") L(20.5")
38	688-45551-01	PINION (13T) PINON (13T)			1	
39	90170-16M01	NUT TUERCA			1	
40	688-45560-00	GEAR 1 (26T) ENGRANAJE 1 (26T)			1	
41	6H1-45611-01	SHAFT, PROPELLER EJE PROPUSOR			1	
42	90501-12M48	SPRING, COMPRESSION RESORTE DE COMPRESION			1	

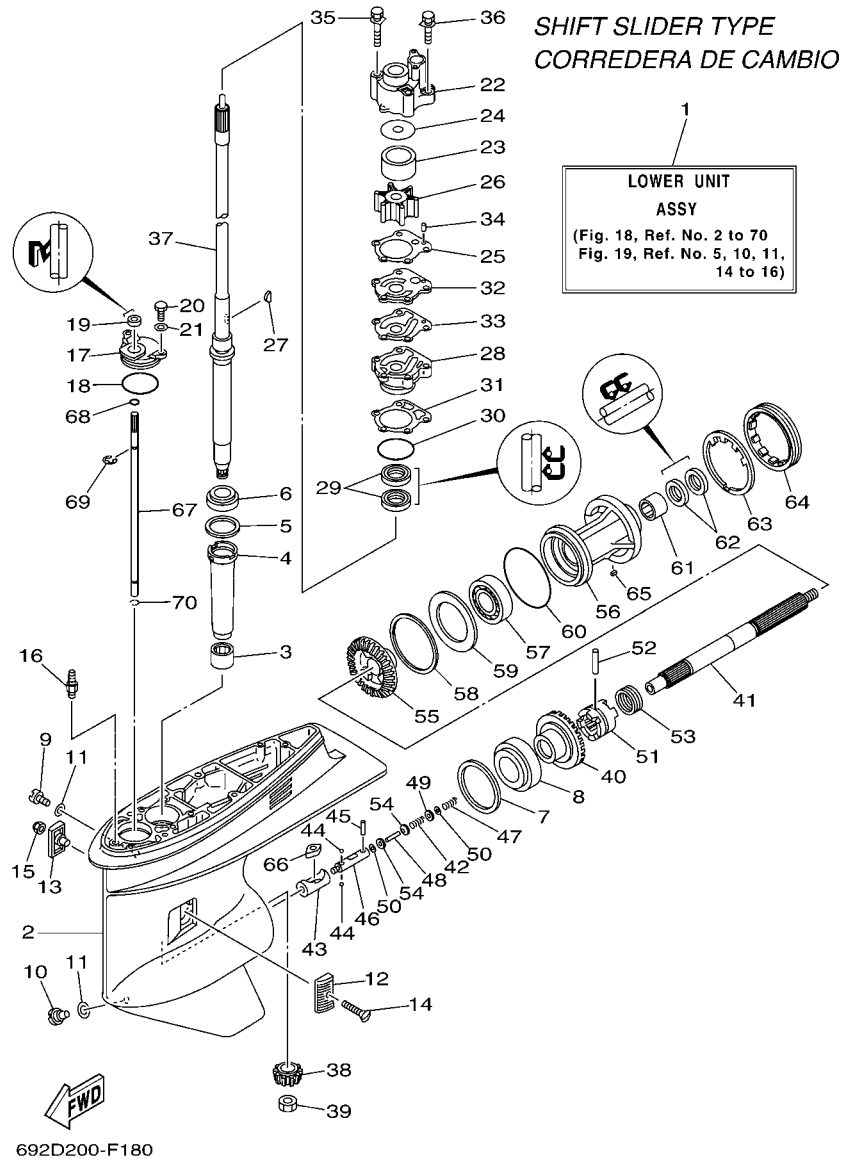
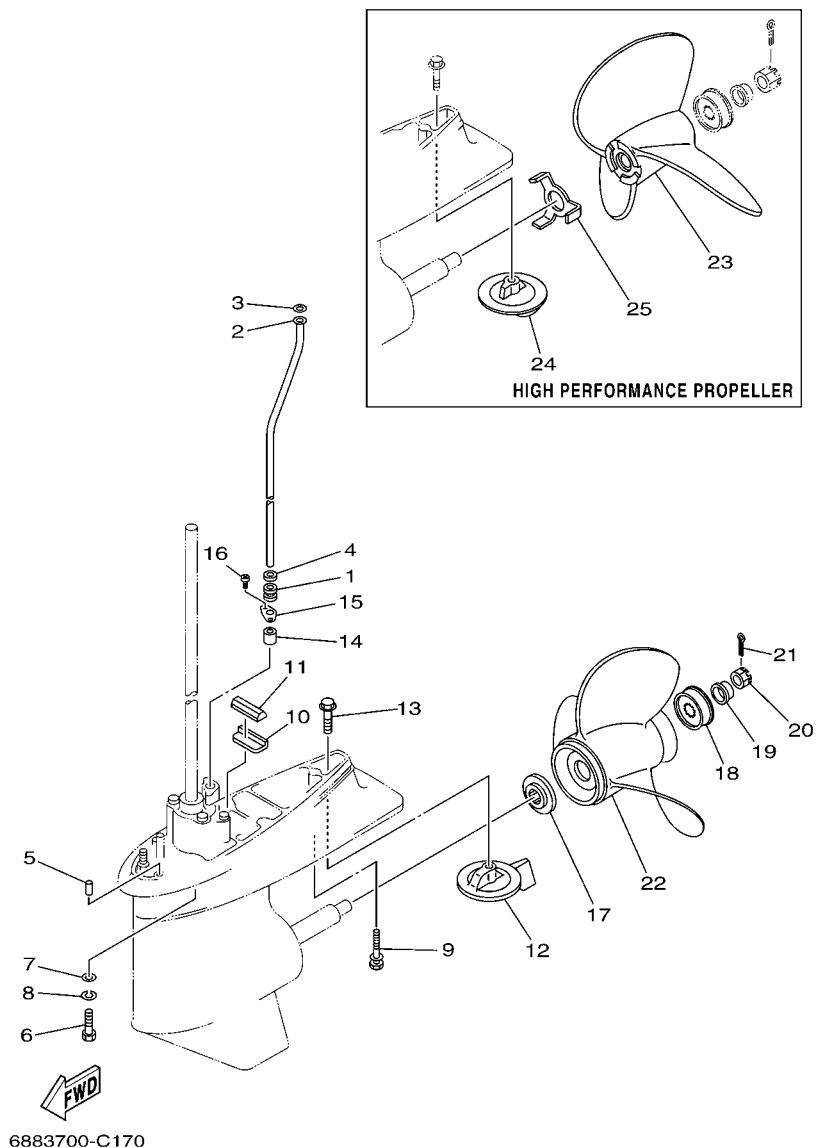

FIG. 18 LOWER CASING & DRIVE 2 IMPULSOR E INFERIOR 2

REF. NO.	PART NO. CODIGO Nº	DESCRIPTION DESCRIPCION	64S6	65S6	692F	REMARKS OBSERVACIONES
43	6H1-45641-01	SHIFTER CAMBIO			1	
44	93503-16003	BALL ESFERA			2	
45	93603-12M11	PIN, DOWEL PASADOR DE CLAVIJA			1	
46	6H1-45634-02	SLIDE, SHIFT DESILIZADOR, CAMBIO			1	
47	90501-16M65	SPRING, COMPRESSION RESORTE DE COMPRESION			1	
48	6H1-45668-00	SHAFT, FREE EJE			1	
49	90201-03313	WASHER, PLATE ARANDELA PLANA			1	
50	90183-02M03	NUT, SPRING TUERCA DE RESORTE			2	
51	6H1-45631-01	CLUTCH, DOG EMBRAGUE DE GARRA			1	
52	90250-07M02	PIN, STRAIGHT PASADOR CILINDRICO			1	
53	688-45633-00	RING, CROSS PIN ANILLO DE PASADOR			1	
54	6H1-45635-00	PLUNGER, SHIFT EMBOLO DE CAMBIO			2	
55	6H1-45571-00	GEAR 2 (26T) ENGRANAJE 2 (26T)			1	
56	688-45331-00-94	HOUSING, BEARING CAJA DE COJINETE			1	
57	93306-207U0	BEARING COJINETE			1	
58	688-45577-01	SHIM (T:0.10MM) LAINA (T:0.10MM)			1	UR
	688-45577-10	SHIM (T:0.12MM) LAINA (:0.12MM)			1	UR
	688-45577-20	SHIM (T:0.15MM) LAINA (T:0.15MM)			1	UR
	688-45577-30	SHIM (T:0.18MM) LAINA (T:0.18MM)			1	UR
	688-45577-40	SHIM (T:0.30MM) LAINA (T:0.30MM)			1	UR
	688-45577-50	SHIM (T:0.40MM) LAINA (T:0.40MM)			1	UR
	688-45577-60	SHIM (T:0.50MM) LAINA (T:0.50MM)			1	UR
59	688-45576-00	WASHER, THRUST ARANDELA DE EMPUJE AXIAL			1	
60	93210-85M97	O-RING ANILLO O			1	
61	93317-325U0	BEARING COJINETE			1	
62	93101-25M03	OIL SEAL SELLO ACEITE			2	
63	688-45383-02	WASHER, CLAW ARANDELA DE UNA			1	

FIG. 19 LOWER CASING & DRIVE 3

IMPULSOR E INFERIOR 3



REF. NO.	PART NO. CODIGO Nº	DESCRIPTION DESCRIPCION	6456	6556	692F	REMARKS OBSERVACIONES
1	663-44367-00	DAMPER, WATER SEAL GOMA DEL SELLO DE AGUA	1	1	1	
2	688-44361-10	TUBE, WATER TUBO DE AGUA	1	1	1	L(20.5") L(20.5")
	692-44361-20	TUBE, WATER TUBO DE AGUA			1	Y(22.5") Y(22.5")
	688-44361-20	TUBE, WATER TUBO DE AGUA		1	1	X(25.5") X(25.5")
3	90202-12060	WASHER, PLATE ARANDELA DE PLANA	1	1	1	
4	90430-12072	GASKET JUNTA	1	1	1	
5	93606-12019	PIN, DOWEL PASADOR DE CLAVIJA	2	2	2	L(20.5") L(20.5")
6	97075-10040	BOLT PERNO	4	4	4	L(20.5") L(20.5")
7	92990-10600	WASHER, PLATE ARANDELA PLANA	4	4	4	
8	92990-10100	WASHER, SPRING ARANDELA PLANA	4	4	4	
9	90119-08M84	BOLT, WITH WASHER TORNILLO CON ARANDELA	1	1	1	L(20.5") L(20.5")
10	663-45376-00-94	GUIDE, SEAL DAMPER GUIA DE SELLO GOMA	1	1	1	
11	688-45375-00	DAMPER, SEAL GOMA DE SELLO	1	1	1	
12	688-45371-02	TAB-TRIM QUILLA ESTABILIZADOR	1	1	1	
13	90105-10M67	BOLT, FLANGE TORNILLO	1	1	1	
14	663-44366-00	DAMPÉR, WATER SEAL GOMA DEL SELLO DE AGUA	1	1	1	
15	90480-19M06	GROMMET TAPON	1	1	1	
16	90160-04006	SCREW, ROUND TAPPING TORNILLO REDONDO ROSCA HEMBRA	2	2	2	
17	688-45987-01	SPACER ESPACIADOR	1	1	1	
18	67F-45997-00	SPACER ESPACIADOR	1	1	1	
19	90389-25M00	BUSH BUJE	1	1	1	
20	90171-16011	NUT, CASTLE TUERCA ENTALLADA	1	1	1	
21	91490-40025	PIN. COTTER CHAVETA	1	1	1	
22	6E5-45941-00-EL	PROPELLER (3X13"X19"-K) PROPELA (3X13"X19"-K)	1	1	1	UR UR
	6E5-45943-00-EL	PROPELLER (3X12-5/8"X21"-K) PROPELA (3X12-5/8"X21"-K)	1	1	1	UR UR
	6E5-45945-01-EL	PROPELLER (3X13-1/4"X17"-K) PROPELA (3X13-1/4"X17"-K)	1	1	1	UR UR
	6E5-45947-00-EL	PROPELLER (3X13-1/2"X15"-K) PROPELA (3X13-1/2"X15"-K)	1	1	1	UR UR

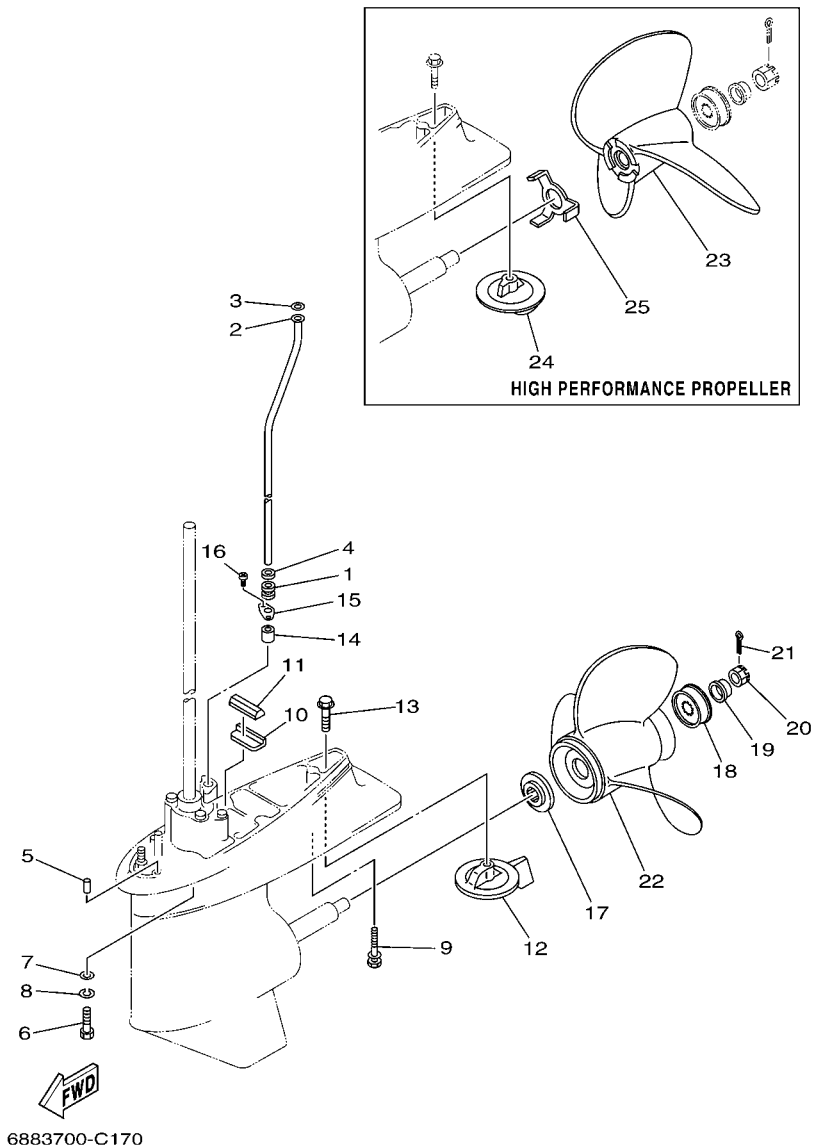
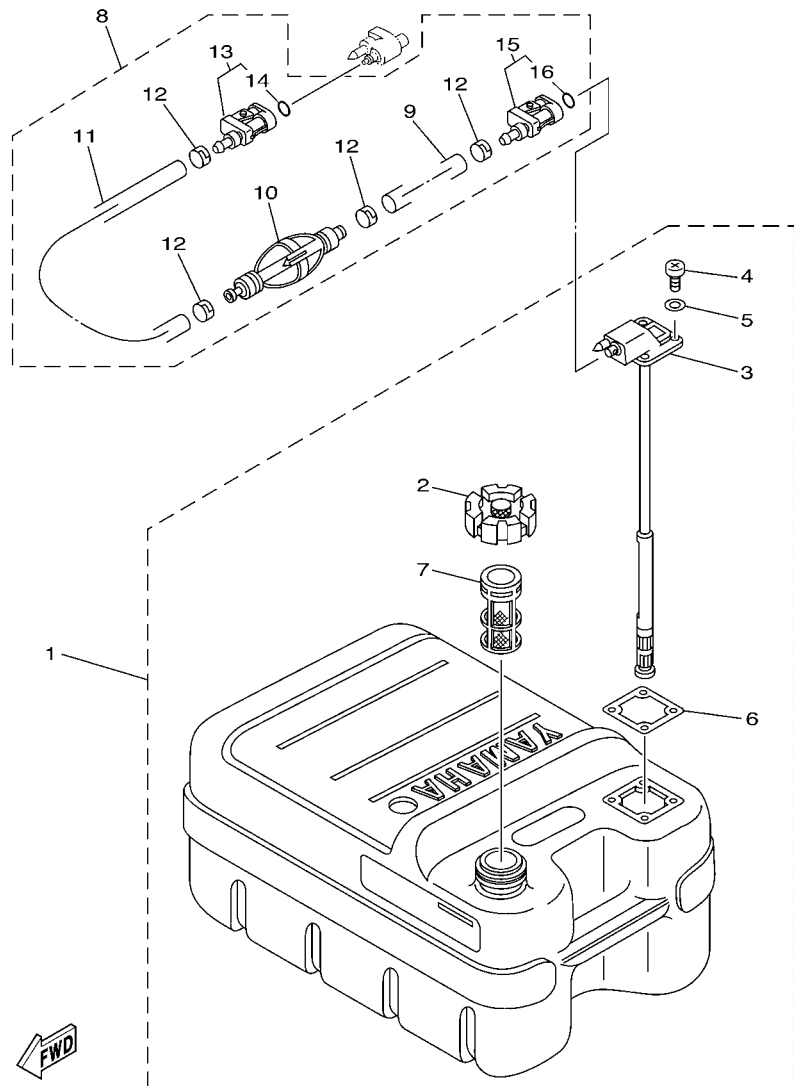

FIG. 19 LOWER CASING & DRIVE 3 IMPULSOR E INFERIOR 3

REF. NO.	PART NO. CODIGO Nº	DESCRIPTION DESCRIPCION	64S6	65S6	692F	REMARKS OBSERVACIONES
22	6E5-45949-00-EL	PROPELLER (3X13-5/8"X13"-K) PROPELA (3X13-5/8"X13"-K)	1	1	1	UR UR
	6E5-45952-00-EL	PROPELLER (3X13"X23"-K) PROPELA (3X13"X23"-K)	1	1	1	UR UR
	6E5-45954-00-EL	PROPELLER (3X14"X11"-K) PROPELA (3X14"X11"-K)	1	1	1	UR UR
	688-45970-03-98	PROPELLER (3X13"X19"-K) PROPELA (3X13"X19"-K)	1	1	1	UR UR
	688-45972-02-98	PROPELLER (3X13"X21"-K) PROPELA (3X13"X21"-K)	1	1	1	UR UR
	688-45974-02-98	PROPELLER (3X13"X23"-K) PROPELA (3X13"X23"-K)	1	1	1	UR UR
	688-45976-01-98	PROPELLER (3X13"X25"-K) PROPELA (3X13"X25"-K)	1	1	1	UR UR
	688-45978-60-98	PROPELLER (3X13-1/2"X16"-K) PROPELA (3X13-1/2"X16"-K)	1	1	1	UR UR
	688-45930-02-98	PROPELLER (3X13"X17"-K) PROPELA (3X13"X17"-K)	1	1	1	UR UR
	688-45932-60-98	PROPELLER (3X13-1/2"X14"-K) PROPELA (3X13-1/2"X14"-K)	1	1	1	UR UR
23	6E5-45970-10	PROPELLER (3X14"X20"-P) PROPELA (3X14"X20"-P)	1	1	1	UR UR
	6E5-45972-10	PROPELLER (3X14"X24"-P) PROPELA (3X14"X24"-P)	1	1	1	UR UR
	6E5-45974-10	PROPELLER (3X14"X28"-P) PROPELA (3X14"X28"-P)	1	1	1	UR UR
	6E5-45976-10	PROPELLER (3X14"X22"-P) PROPELA (3X14"X22"-P)	1	1	1	UR UR
	6E5-45978-10	PROPELLER (3X14"X26"-P) PROPELA (3X14"X26"-P)	1	1	1	UR UR
24	6E5-45371-10	TAB-TRIM QUILLA ESTABILIZADOR	1	1	1	
25	6E5-45994-10	PLATE, TOOTH PLACA	1	1	1	



68U3100-C240

FIG. 20 FUEL TANK

DEPOSITO DE COMBUSTIBLE

REF. NO.	PART NO. CODIGO Nº	DESCRIPTION DESCRIPCION	64S6	65S6	692F	REMARKS OBSERVACIONES
1	6YJ-24201-00	FUEL TANK ASSY (24L) TANQUE DEL COMBUSTIBLE (24L)	1	1	1	AP AP
2	6YJ-24610-01	.CAP ASSY .TAPA COMPLETA	1	1	1	
3	6YJ-24260-00	.FUEL METER ASSY .MEDIDOR DE COMBUSTIBLE COMPL.	1	1	1	
4	90157-05M19	.SCREW, PAN HEAD .TORNILLO CABEZA CONICA PLANA	4	4	4	
5	6Y1-24329-00	.SEAL .SELLO	4	4	4	
6	6Y1-24268-00	.GASKET, FUEL METER .EMPAQ MEDIDOR DE COMBUSTIBLE	1	1	1	
7	6YJ-24167-00	.STRAINER .COLADOR	1	1	1	
8	61J-24306-04	FUEL PIPE COMP. 1 TUBO COMBUST. COMPL 1	1	1	1	AP AP
9	90445-11M06	.HOSE (L2050) .MANGUERA (L2050)	1	1	1	
10	61J-24360-00	.PRIMER PUMP ASSY .SOPORTE BOMBA	1	1	1	
11	90445-11M05	.HOSE (L850) .MANGUERA (L850)	1	1	1	
12	650-24351-01	.BAND 1 .ABRAZADERA 1	4	4	4	
13	6G1-24305-05	.FUEL PIPE JOINT COMP. 2 .CONECTOR MANGUERA COMBUST. 2	1	1	1	
14	93210-08287	..O-RING ..ANILLO O	1	1	1	
15	6Y1-24305-06	.FUEL PIPE JOINT COMP. 2 .CONECTOR MANGUERA COMBUST. 2	1	1	1	
16	93210-08287	..O-RING ..ANILLO O	1	1	1	

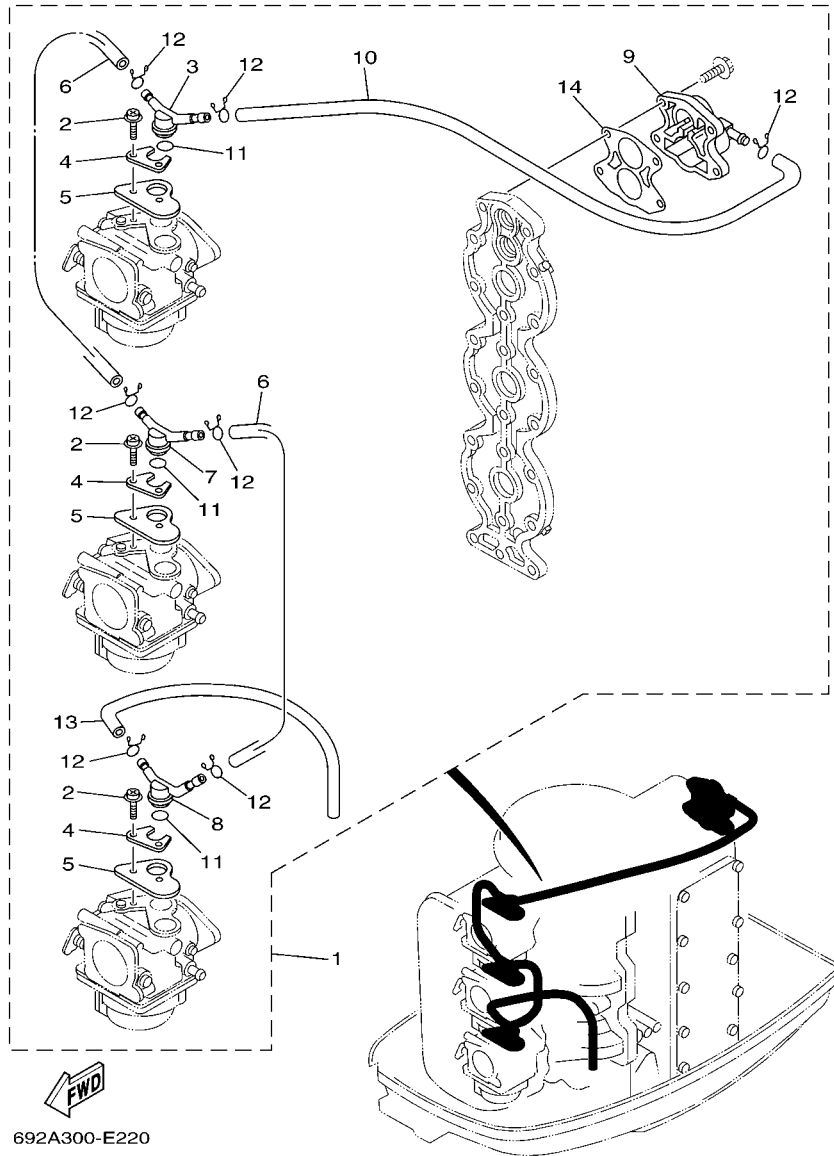

FIG. 21 OPTIONAL PARTS

PARTES OPCIONALES

REF. NO.	PART NO. CODIGO Nº	DESCRIPTION DESCRIPCION	64S6	65S6	692F	REMARKS OBSERVACIONES
1	688-12440-51	HEAT EXCHANGER ASSY INTERCAMBIADOR DE CALOR COMPL	1	1	1	AP AP
2	97980-05114	.SCREW, WITH WASHER .TORNILLO, CON ARANDELA	6	6	6	
3	6H1-14969-50	.CAP .TAPA	1	1	1	
4	6H1-14945-50	.PLATE .PLACA	3	3	3	
5	6H1-14572-50	.PLATE, STAY .PLACA DE SOPORTE	3	3	3	
6	90445-11M01	.HOSE (L180) .TUBO (L180)	2	2	2	
7	6H1-14169-50	.CAP .FUNDA	1	1	1	
8	6H1-14968-50	.CAP .TAPA	1	1	1	
9	6H1-12413-50	.COVER, THERMOSTAT .CUBIERTA TERMOSTATO	1	1	1	
10	6H1-14348-51	.PIPE 1 .MANGUERA	1	1	1	
11	93210-15M52	.O-RING .ANILLO O	3	3	3	
12	90467-10M04	.CLIP .PRESILLA	7	7	7	
13	6E5-12481-00	.PIPE 1 .TUBO 1	1	1	1	
14	6H1-12414-50	.GASKET, COVER .EMPAQUE	1	1	1	

FIG. 22 REPAIR KIT 1

ESTUCHE REPARATION 1

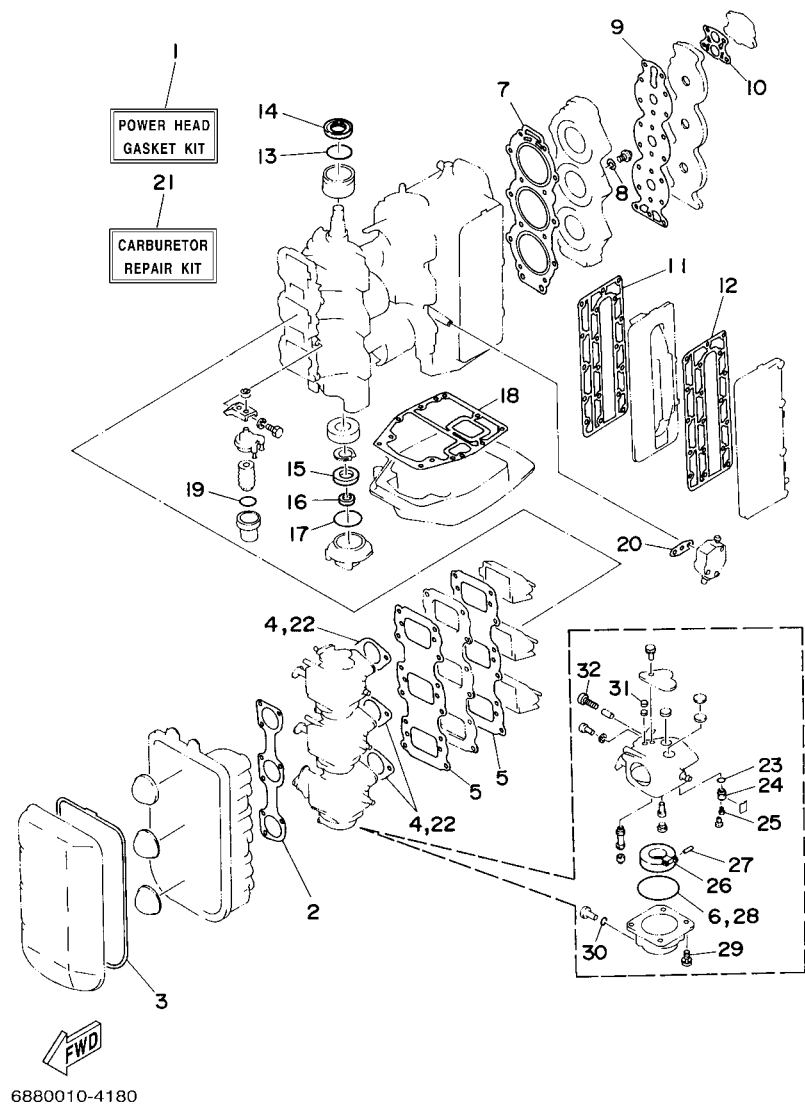

REF. NO.	PART NO. CODIGO Nº	DESCRIPTION DESCRIPCION	64S6	65S6	692F	REMARKS OBSERVACIONES
1	688-W0001-02	POWER HEAD GASKET KIT JUEGO DE EMPAQUE	1	1	1	
2	688-14483-A0	.GASKET .EMPAQUE	1	1	1	
3	688-14416-01	.GASKET, AIR CLEANER .EMPAQUE	1	1	1	
4	688-14198-A2	.GASKET .EMPAQUE	3	3	3	
5	688-13621-A1	.GASKET, VALVE SEAT .JUNTA, DE VALV.DE EMPAQUE	2	2	2	
6	676-14984-00	.GASKET, FLOAT CHAMBER .EMPAQUE CAMARA DE BOIA	3	3	3	
7	688-11181-A1	.GASKET, CYLINDER HEAD 1 .JUNTA, DE CULATA 1	1	1	1	
8	90430-14115	.GASKET .JUNTA	1	1	1	
9	688-11193-A1	.GASKET, HEAD COVER 1 .EMPAQUE	1	1	1	
10	688-12414-A1	.GASKET, COVER .EMPAQUE	1	1	1	
11	688-41112-A0	.GASKET, EXHAUST INNER COVER .EMPAQUE	1	1	1	
12	688-41114-A0	.GASKET, EXHAUST OUTER COVER .EMPAQUE	1	1	1	
13	93210-46M16	.O-RING .ANILLO O	1	1	1	
14	93102-36M02	.OIL SEAL .SELLO ACEITE	1	1	1	
15	93102-30M05	.OIL SEAL .SELLO ACEITE	1	1	1	
16	93104-20M02	.OIL SEAL .SELLO ACEITE	1	1	1	
17	93210-62269	.O-RING .ANILLO O	1	1	1	
18	688-45113-A0	.GASKET, UPPER CASING .EMPAQUE	1	1	1	
19	93210-32738	.O-RING .ANILLO O	1	1	1	
20	650-24431-A0	.GASKET, FUEL PUMP 1 .EMPAQUE BOMBA COMBUST 1	1	1	1	
21	6H1-W0093-01	CARBURETOR REPAIR KIT KIT REPARACION CARBURADOR	1	1	1	
22	688-14198-A2	.GASKET .EMPAQUE	3	3	3	
23	93210-04228	.O-RING .ANILLO O	3	3	3	
24	692-14590-01	.NEEDLE VALVE ASSY .VALVULA DE AGUJA COMPLETA	3	3	3	
25	676-14186-00	.PIN, FLOAT .PASADOR DE LA BOYA	3	3	3	
26	676-14985-01	.FLOAT .BOIA	3	3	3	
27	688-14548-00	.PIN, FLOAT ARM .PASADOR DE BRAZO DE BOIA	3	3	3	

FIG. 23 REPAIR KIT 2

ESTUCHE REPARATION 2

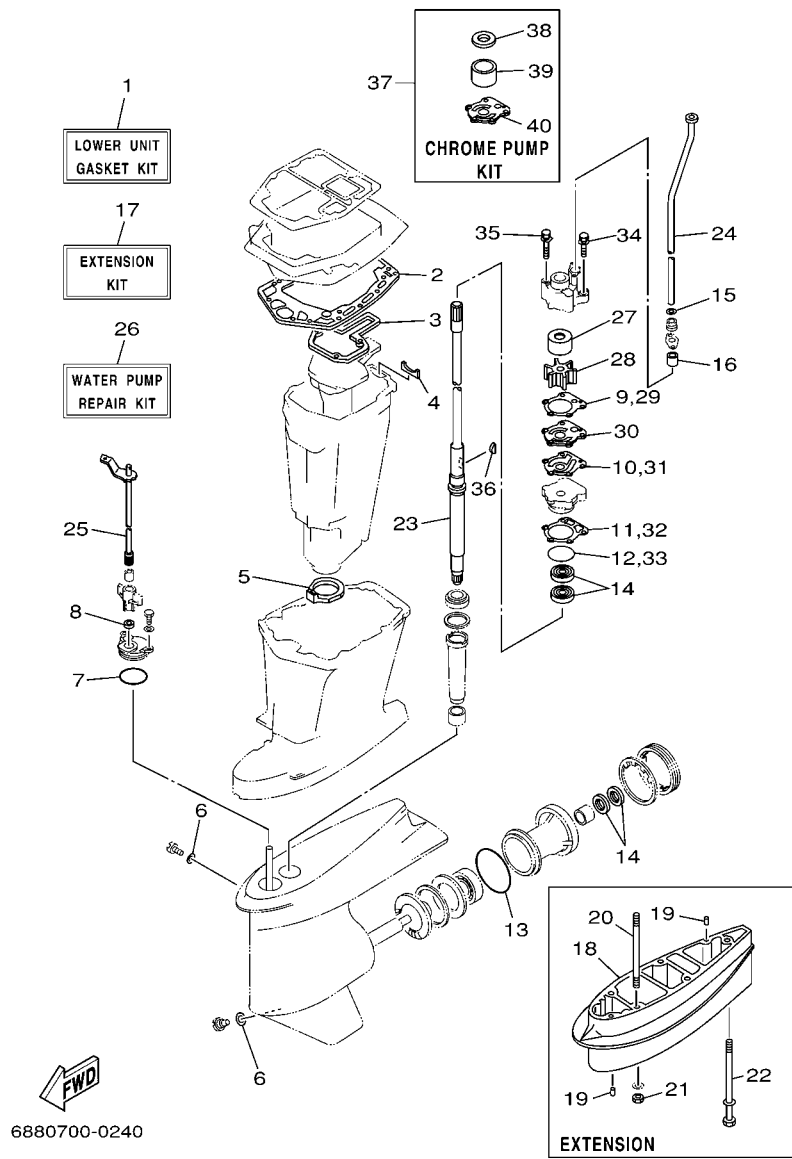

6880700-0240

REF. NO.	PART NO. CODIGO Nº	DESCRIPTION DESCRIPCION	64S6	65S6	692F	REMARKS OBSERVACIONES
1	688-W0001-22	LOWER UNIT GASKET KIT JUEGO DE EMPAQUE UNIDAD INFER.	1	1	1	
2	688-45114-A1	.GASKET, UPPER CASING .EMPAQUE	1	1	1	
3	688-41134-A0	.GASKET, EXHAUST MANIFOLD .EMPAQUE	1	1	1	
4	688-41133-00	.GASKET, EXHAUST MANIFOLD 1 .EMPAQUE ESCAPE MULTIPLE	1	1	1	
5	688-45123-00	.GASKET, MUFFLER .EMPAQUE SILENCIADOR	1	1	1	
6	90430-08020	.GASKET .JUNTA	2	2	2	
7	93210-49046	.O-RING .ANILLO O	1	1	1	
8	93106-09014	.OIL SEAL .SELLO ACEITE	1	1	1	
9	688-44315-A0	.GASKET, WATER PUMP .EMPAQUE	1	1	1	
10	688-44324-A0	.GASKET, CARTRIDGE .EMPAQUE	1	1	1	
11	688-44316-A0	.GASKET, WATER PUMP .EMPAQUE	1	1	1	
12	93210-46044	.O-RING .ANILLO O	1	1	1	
13	93210-85M97	.O-RING .ANILLO O	1	1	1	
14	93101-25M03	.OIL SEAL .SELLO ACEITE	4	4	4	
15	90430-12072	.GASKET .JUNTA	1	1	1	
16	663-44366-00	.DAMPER, WATER SEAL .GOMA DEL SELLO DE AGUA	1	1	1	
17	688-W0072-00-4D	EXTENSION KIT ESTUCHE PARA EXTENSION	1	1		X(25.5") X(25.5")
18	688-45211-01-4D	.EXTENSION .EXTENSION	1	1		
19	93606-12019	.PIN, DOWEL .PASADOR DE CLAVIJA	4	4		
20	90116-10M05	.BOLT, STUD .ESPARRAGO	4	4		
21	95380-10600	.NUT .TUERCA	4	4		
22	90119-08M86	.BOLT, WITH WASHER .TORNILLO CON ARANDELA	1	1		
23	688-45501-22	.DRIVE SHAFT COMP. .EJE DE MANDO COMPL.	1	1		
24	688-44361-20	.TUBE, WATER .TUBO DE AGUA	1	1		
25	688-44120-22	.HANDLE GEAR SHIFT ASSY .MANIJA DE CAMBIO COMPL	1	1		
26	692-W0078-02	WATER PUMP REPAIR KIT ESTUCHE REPARACION BOMBA AGUA	1	1	1	
27	688-44322-00	.INSERT, CARTRIDGE .CARTUCHO	1	1	1	

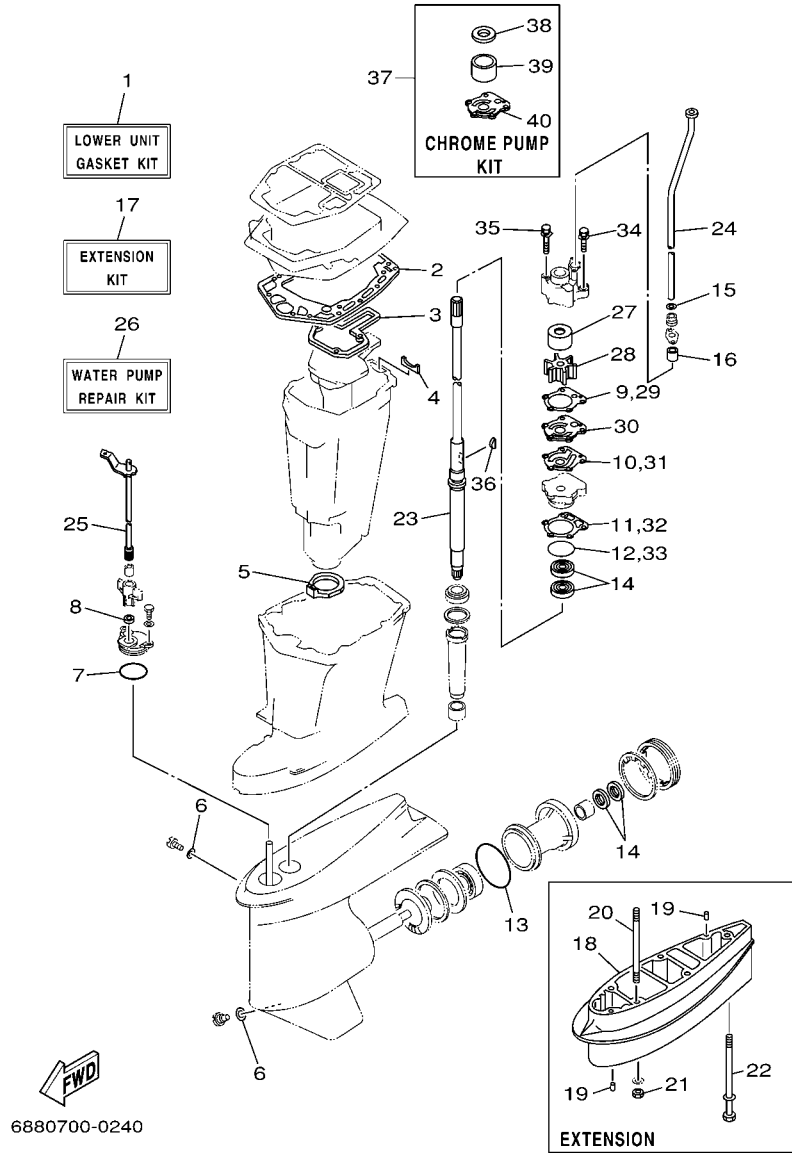

FIG. 23 REPAIR KIT 2

ESTUCHE REPARATION 2

REF. NO.	PART NO. CODIGO N°	DESCRIPTION DESCRIPCION	64S6	65S6	692F	REMARKS OBSERVACIONES
28	688-44352-03	.IMPELLER .IMPULSOR	1	1	1	
29	688-44315-A0	.GASKET, WATER PUMP .EMPAQUE	1	1	1	
30	688-44323-00	.OUTER PLATE, CARTRIDGE .PLACA EXTERIOR DEL CARTUCHO	1	1	1	
31	688-44324-A0	.GASKET, CARTRIDGE .EMPAQUE	1	1	1	
32	688-44316-A0	.GASKET, WATER PUMP .EMPAQUE	1	1	1	
33	93210-46044	.O-RING .ANILLO O	1	1	1	
34	90119-08M13	.BOLT, WITH WASHER .TORNILLO CON ARANDELA	2	2	2	
35	90119-08M16	.BOLT, WITH WASHER .TORNILLO CON ARANDELA	2	2	2	
36	90280-04M04	.KEY, WOODRUFF .CUNA WOODRUFF	1	1	1	
37	688-W0078-1A	CHROME PUMP KIT ESTUCHE REPARACION BOMBA AGUA	1	1	1	
38	688-44321-41	.INNER PLATE, CARTRIDGE .PLACA INTERIOR CARTUCHO	1	1	1	
39	688-44322-41	.INSERT, CARTRIDGE .CARTUCHO	1	1	1	
40	688-44323-40	.OUTER PLATE, CARTRIDGE .PLACA EXTERIOR DEL CARTUCHO	1	1	1	

NUMERICAL INDEX
INDICE NUMERICO

PART NO. CODIGO N°	REF. NO.	PART NO. CODIGO N°	REF. NO.	PART NO. CODIGO N°	REF. NO.	PART NO. CODIGO N°	REF. NO.	PART NO. CODIGO N°	REF. NO.	PART NO. CODIGO N°	REF. NO.
692-11111-01-1S	2 - 27	692-14301-45	5 - 1	6H3-14992-00	5 - 18	650-24351-01	20 - 12	661-41262-02	4 - 5	688-42817-01-4D	10 - 4
692-11119-01	2 - 25	692-14301-60	5 - 1	688-15100-06-1S	2 - 2	61J-24360-00	20 - 10	689-41273-00	4 - 2	688-43111-13-4D	13 - 1
688-11181-A1	2 - 28	692-14302-45	5 - 2	6H1-15359-01-94	3 - 1	688-24378-00	6 - 37	688-41611-00	8 - 10	688-43112-12-4D	13 - 8
	22 - 7	692-14302-60	5 - 2	688-15379-00	3 - 6	692-24410-00	6 - 15	688-41612-00	8 - 11	688-43124-02	14 - 12
688-11191-00-1S	2 - 32	692-14303-45	5 - 3	692-15711-00	7 - 2	663-24411-00	6 - 20	688-41631-01-94	12 - 18	6E5-43126-02	13 - 36
688-11193-A1	2 - 33	692-14303-60	5 - 3	663-15713-00	7 - 5	692-24411-00	6 - 17	688-41632-01-94	12 - 7	688-43128-01-4D	14 - 1
	22 - 9	6A0-14325-00	6 - 25	663-15714-01	7 - 6	6A0-24412-02	6 - 26	692-42111-12-4D	11 - 2	688-43131-03	13 - 16
688-11325-00	2 - 23	67C-1432A-00	5 - 33	663-15715-00	7 - 12	6A0-24413-00	6 - 16	692-42115-00	11 - 11	6G5-43144-00	13 - 30
650-11370-01	2 - 4	6H1-14348-51	21 - 10	663-15716-01	7 - 13	6A0-24421-01	6 - 24	664-42119-00	11 - 3	6G5-43145-01	13 - 20
688-11370-01	2 - 3	688-14416-01	4 - 24	663-15719-00	7 - 15	650-24431-A0	6 - 27	692-42121-02-4D	11 - 21	6G5-43148-00	13 - 25
	3 - 2		22 - 3	6K5-15723-00	7 - 26		22 - 20	663-42126-01	11 - 47	688-43160-01	13 - 32
688-11411-01	3 - 11	688-14417-01-94	4 - 19	663-15726-01	7 - 10	648-24434-01	6 - 18	663-42133-01	11 - 15	688-43165-00	13 - 33
663-11518-01	2 - 6	688-14418-01	4 - 23	663-15734-01	7 - 14	648-24435-02	6 - 21	692-42134-03-94	11 - 16	688-43170-04-4D	14 - 7
688-11603-A0	3 - 19	688-14481-00	4 - 22	663-15735-01	7 - 55	68V-24469-01	6 - 10	692-42135-00	11 - 14	688-43181-10	13 - 21
688-11604-A0	3 - 19	688-14483-A0	4 - 20	663-15736-00	7 - 62	68V-24521-01	6 - 8	692-42137-02	11 - 5	688-43185-10	13 - 22
688-11605-A0	3 - 19		22 - 2	663-15739-00	7 - 4	64J-24560-00	6 - 6	663-42138-00	11 - 12	688-43186-00	14 - 2
688-11631-03-94	3 - 18	624-14485-00	2 - 5	663-15741-02	7 - 8	61N-24563-00	6 - 7	692-42164-00	11 - 42	6H1-43311-02-4D	13 - 13
663-11633-00	3 - 20	6H1-14488-00	4 - 27	663-15744-00	7 - 11	648-24566-02	6 - 11	6F6-42177-A0	11 - 4	663-43318-00	13 - 23
688-11634-00	3 - 21	63V-14523-00	5 - 30	663-15752-00	7 - 18	6YJ-24610-01	20 - 2	692-42510-00-4D	15 - 1	682-43318-01	14 - 10
688-11635-03	3 - 18	663-14527-00	5 - 21	663-15753-00	7 - 19	692-26301-03	11 - 20	692-42515-01	11 - 55	688-43616-00	14 - 5
688-11636-03	3 - 18	688-14527-00	5 - 23	663-15754-00	7 - 9	670-28100-03	6 - 39	663-42518-00	11 - 51	688-43631-10	14 - 8
688-11650-03	3 - 22	688-14548-00	5 - 14	689-15755-01	7 - 23	6A1-28176-00	10 - 31	663-42528-00	11 - 52	688-43651-00	14 - 9
688-12411-11	2 - 38		22 - 27	692-15758-01-94	7 - 47	6E0-28193-00-94	6 - 40	692-42610-F0-4D	1 - 1	697-43662-00	12 - 56
688-12412-00	2 - 39	679-14555-00	5 - 27	697-15761-01	1 - 18	61H-2819R-31	6 - 38	692-42610-K0-4D	1 - 1	697-44113-00	11 - 29
688-12413-00-1S	2 - 40	688-14572-01	5 - 24	697-15762-00	7 - 53	688-41111-00-1S	2 - 43	692-42610-L0-4D	1 - 1	688-44117-00-94	12 - 35
6H1-12413-50	21 - 9	6H1-14572-50	21 - 5	663-15764-00	7 - 7	688-41112-A0	2 - 44	692-42613-01-4D	1 - 10	688-44118-01-94	12 - 44
6H1-12414-50	21 - 14	6H2-14578-00	5 - 32	692-15770-01	7 - 54		22 - 11	688-42615-00	1 - 15	692-44120-00	12 - 51
688-12414-A1	2 - 41	692-14590-01	5 - 9	692-15771-00	7 - 32	688-41113-00-1S	2 - 46	688-42647-00-94	1 - 2	692-44120-12	12 - 51
	22 - 10		22 - 24	692-15772-00	7 - 37	688-41114-A0	2 - 45	692-42649-00-94	1 - 3	688-44120-22	23 - 25
688-12416-00	2 - 36	6K5-14592-00	5 - 28	663-15772-01	7 - 67		22 - 12	688-42652-10	1 - 5	692-44120-22	12 - 51
688-12440-51	21 - 1	688-14711-01-5B	16 - 10	648-15773-00	7 - 3	688-41131-00-5B	16 - 8	663-42662-00	1 - 4	692-44120-42	12 - 51
6E5-12481-00	21 - 13	688-14711-10-5B	16 - 10	6F5-15779-02	7 - 25	688-41131-10-5B	16 - 8	69P-42677-H0	1 - 20	6H1-44121-00	12 - 42
677-13437-0B	1 - 19	663-14737-10	16 - 12	697-15787-00-94	7 - 42	688-41133-00	16 - 9	692-42678-H0	1 - 17	688-44121-02	12 - 42
688-13610-00	4 - 13	692-14923-00	5 - 26	697-15789-00	7 - 48		23 - 4	6K5-42678-H0	1 - 17	688-44122-00	12 - 39
688-13621-A1	4 - 11		22 - 32	663-15791-00	7 - 20	688-41134-A0	16 - 7	692-42678-W0	1 - 17	688-44124-00	12 - 38
	22 - 5	676-14943-41	5 - 5	663-15794-00	7 - 61		23 - 3	692-42711-02-4D	10 - 1	6H1-44144-00	18 - 67
688-13624-00	4 - 12	6H1-14945-50	21 - 4	6YJ-24167-00	20 - 7	688-41137-03-94	16 - 5	648-42715-00	12 - 50	663-44144-01	17 - 59
688-13641-00-94	4 - 6	692-14947-00	5 - 4	6YJ-24201-00	20 - 1	688-41211-01	12 - 28	688-42716-02	10 - 9	696-44147-00	12 - 52
663-14126-00	5 - 20	676-14948-18	5 - 6	6YJ-24260-00	20 - 3	688-41213-00	12 - 31	663-42724-00	10 - 10	663-44151-00	17 - 58
	22 - 31	676-14966-00	5 - 7	6Y1-24268-00	20 - 6	692-41213-00	12 - 31	692-42725-10	10 - 11	6H1-44151-00	18 - 66
688-14126-00	5 - 22	6H1-14968-50	21 - 8	6G1-24304-02	6 - 1	662-41214-01	12 - 8	6H4-42726-00	10 - 22	692-44159-01	11 - 33
663-14159-00	5 - 10	6H1-14969-50	21 - 3	6G1-24305-05	20 - 13	688-41217-01	4 - 3	688-42738-01-94	10 - 12	663-44173-00	11 - 34
6H1-14169-50	21 - 7	688-14980-00	5 - 16	6Y1-24305-06	20 - 15	682-41237-00	12 - 27	688-42741-01-4D	10 - 23	6K5-44191-00	11 - 30
676-14186-00	5 - 11	676-14984-00	5 - 15	61J-24306-04	20 - 8		12 - 30	688-42771-01-4D	10 - 24	688-44194-00	2 - 13
	22 - 25		22 - 6	663-24312-01	2 - 47	682-41237-50	12 - 25	6G5-42791-00	10 - 33		12 - 22
688-14198-A2	4 - 8		22 - 28	688-24313-00	6 - 33	692-41256-00	4 - 1	6G5-42791-10	10 - 33	688-44311-01	17 - 21
	22 - 4	676-14985-01	5 - 13	688-24314-00	6 - 34	688-41257-01	4 - 4	688-42815-01-4D	10 - 3		18 - 22
	22 - 22		22 - 26	6Y1-24329-00	20 - 5	6J8-41262-00	14 - 4	688-42816-00	10 - 7	688-44315-A0	17 - 24

NUMERICAL INDEX
INDICE NUMERICO

PART NO. CODIGO N°	REF. NO.	PART NO. CODIGO N°	REF. NO.	PART NO. CODIGO N°	REF. NO.	PART NO. CODIGO N°	REF. NO.	PART NO. CODIGO N°	REF. NO.	PART NO. CODIGO N°	REF. NO.
688-44315-A0	18 - 25	688-45114-A1	23 - 2	6K5-45560-00	17 - 39	688-45611-00	17 - 40	61A-82519-00	9 - 31	90119-06M09	10 - 8
	23 - 9	663-45119-00	13 - 15	688-45567-01	17 - 7	6H1-45611-01	18 - 41	697-82519-00	9 - 30	90119-06M12	2 - 8
	23 - 29	688-45123-00	16 - 11		18 - 7	688-45631-01	17 - 43	682-82556-00	11 - 59	90119-06M24	12 - 34
688-44316-A0	17 - 30		23 - 5	688-45567-10	17 - 7	6H1-45631-01	18 - 51	688-82560-10	9 - 26	90119-06M29	13 - 4
	18 - 31	663-45155-10	16 - 2		18 - 7	688-45633-00	17 - 45	697-82575-00	11 - 58	90119-06M30	7 - 43
	23 - 11	688-45211-01-4D	16 - 27	688-45567-20	17 - 7		18 - 53	6E3-8257H-00	10 - 32	90119-06M61	10 - 19
	23 - 32		23 - 18		18 - 7	688-45634-00	17 - 42	689-8257Y-00	11 - 60	90119-06M75	9 - 16
688-44321-41	17 - 23	696-45211-01-4D	16 - 22	688-45567-30	17 - 7	6H1-45634-02	18 - 46	688-82588-01	9 - 27	90119-06MA3	2 - 34
	18 - 24	6H1-45214-00	17 - 12		18 - 7	688-45635-00	17 - 46	692-82590-00	9 - 28	90119-06MA5	2 - 42
	23 - 38		18 - 12	688-45567-40	17 - 7	6H1-45635-00	18 - 54	6A1-83625-41	4 - 28	90119-08020	2 - 49
688-44322-00	23 - 27	6H1-45215-00	17 - 13		18 - 7	6H1-45641-01	18 - 43	6E0-83627-41	11 - 63	90119-08M13	17 - 35
688-44322-41	17 - 22		18 - 13	688-45567-50	17 - 7	6H1-45668-00	18 - 48	6H4-85411-00	10 - 30		18 - 36
	18 - 23	6H1-45251-03	13 - 2		18 - 7	688-45930-02-98	19 - 22	692-85415-00	10 - 29		23 - 34
	23 - 39	692-45300-14-4D	17 - 1	688-45567-60	17 - 7	688-45932-60-98	19 - 22	688-85510-01	8 - 2	90119-08M16	17 - 34
688-44323-00	23 - 30	692-45300-24-4D	17 - 1		18 - 7	6E5-45941-00-EL	19 - 22	663-85518-00	12 - 19		18 - 35
688-44323-40	17 - 31	692-45300-34-4D	17 - 1	6H1-45571-00	18 - 55	6E5-45943-00-EL	19 - 22	688-85540-00	9 - 1		23 - 35
	18 - 32	692-45300-40-4D	18 - 1	6K5-45571-00	17 - 47	6E5-45945-01-EL	19 - 22	6H1-85542-00-94	9 - 13	90119-08M26	7 - 29
	23 - 40	692-45300-62-4D	17 - 1	688-45571-01	17 - 47	6E5-45947-00-EL	19 - 22	692-85550-00	8 - 1	90119-08M79	16 - 17
688-44324-A0	17 - 32	692-45300-80-4D	17 - 1	688-45576-00	17 - 51	6E5-45949-00-EL	19 - 22	697-85570-00	9 - 5	90119-08M80	16 - 4
	18 - 33	6H1-45301-03-4D	18 - 2		18 - 59	6E5-45952-00-EL	19 - 22	688-85580-00	8 - 3	90119-08M84	19 - 9
	23 - 10	688-45311-06-4D	17 - 2	688-45577-01	17 - 50	6E5-45954-00-EL	19 - 22	688-W0001-02	22 - 1	90119-08M85	16 - 26
	23 - 31	688-45321-00	17 - 16		18 - 58	688-45970-03-98	19 - 22	688-W0001-22	23 - 1	90119-08M86	16 - 31
688-44341-01-94	17 - 27		18 - 17	688-45577-10	17 - 50	6E5-45970-10	19 - 23	688-W0004-00	4 - 14		23 - 22
	18 - 28	688-45331-00-94	17 - 48		18 - 58	688-45972-02-98	19 - 22	692-W0070-H0	1 - 16	90119-08MA3	2 - 26
688-44352-03	17 - 25		18 - 56	688-45577-20	17 - 50	6E5-45972-10	19 - 23	692-W0070-J0	1 - 16	90119-08MA8	2 - 29
	18 - 26	688-45341-10	17 - 10		18 - 58	688-45974-02-98	19 - 22	692-W0070-W0	1 - 16	90119-10005	2 - 9
	23 - 28		18 - 10	688-45577-30	17 - 50	6E5-45974-10	19 - 23	688-W0072-00-4D	23 - 17	90149-05095	7 - 58
688-44361-10	19 - 2	688-45371-02	19 - 12		18 - 58	688-45976-01-98	19 - 22	692-W0078-02	23 - 26	90149-05M13	11 - 7
688-44361-20	19 - 2	6E5-45371-10	19 - 24	688-45577-40	17 - 50	6E5-45976-10	19 - 23	688-W0078-1A	23 - 37	90151-05M00	17 - 14
	23 - 24	688-45375-00	19 - 11		18 - 58	6E5-45978-10	19 - 23	692-W0084-11-4D	11 - 1		18 - 14
692-44361-20	19 - 2	663-45376-00-94	19 - 10	688-45577-50	17 - 50	688-45978-60-98	19 - 22	692-W0090-44-1S	2 - 1	90157-05M19	20 - 4
663-44366-00	19 - 14	6J8-45378-00	18 - 16		18 - 58	688-45987-01	19 - 17	6H1-W0093-01	22 - 21	90157-06013	12 - 21
	23 - 16	688-45383-02	17 - 55	688-45577-60	17 - 50	6E5-45994-10	19 - 25	692-W1571-02	7 - 1	90157-06014	2 - 12
663-44367-00	19 - 1		18 - 63		18 - 58	67F-45997-00	19 - 18	90101-06M27	11 - 48	90159-06M11	9 - 24
6H3-44391-01	10 - 2	688-45384-00	17 - 56	688-45587-01	17 - 5	700-48339-00	11 - 46	90101-10M49	15 - 25	90159-06M31	8 - 12
688-44511-00-94	15 - 31		18 - 64		18 - 5	663-48344-00	12 - 6	90101-12M06	11 - 22	90160-04006	19 - 16
688-44514-00-94	15 - 24	688-45501-11	17 - 36	688-45587-10	17 - 5	663-48531-00	12 - 1	90101-12M65	13 - 40	90170-16M01	17 - 38
6H1-44526-00	13 - 3		18 - 37		18 - 5	663-48538-00	12 - 2	90105-10M67	19 - 13		18 - 39
692-44551-00-4D	15 - 7	692-45501-21	17 - 36	688-45587-20	17 - 5	688-81332-01	8 - 13	90109-06M39	9 - 17	90170-20137	8 - 8
687-44552-02-94	15 - 16	688-45501-22	17 - 36		18 - 5	6H1-81916-00	9 - 23	90109-08022	3 - 23	90171-16011	19 - 20
663-44553-01-4D	15 - 21		23 - 23	688-45587-30	17 - 5	6H0-81960-00	9 - 8	90109-12261	15 - 13	90175-06003	11 - 50
687-44555-00-94	15 - 9	688-45536-01	17 - 4		18 - 5	703-82119-00	9 - 29	90116-06122	4 - 7		11 - 54
663-44575-00	15 - 14		18 - 4	688-45587-40	17 - 5		10 - 21	90116-06M22	9 - 19	90179-06066	15 - 20
	15 - 30	6K5-45551-00	17 - 37		18 - 5	688-82127-02	15 - 23	90116-10M05	16 - 28	90183-02M03	18 - 50
688-45111-04-4D	16 - 1	688-45551-01	17 - 37	688-45587-50	17 - 5	6E5-82148-00	13 - 9		23 - 20	90185-05002	17 - 15
688-45113-A0	16 - 20		18 - 38		18 - 5	6A0-82317-00	7 - 45	90116-10M06	2 - 20		18 - 15
	22 - 18	688-45560-00	17 - 39	688-45587-60	17 - 5	663-82370-01	9 - 25	90116-10M28	15 - 34	90185-08057	11 - 57
688-45114-A1	16 - 6		18 - 40		18 - 5	6G1-82370-21	9 - 25	90116-10M31	16 - 23	90185-10051	11 - 39

NUMERICAL INDEX
INDICE NUMERICO

PART NO. CODIGO N°	REF. NO.	PART NO. CODIGO N°	REF. NO.	PART NO. CODIGO N°	REF. NO.	PART NO. CODIGO N°	REF. NO.	PART NO. CODIGO N°	REF. NO.	PART NO. CODIGO N°	REF. NO.
90185-10051	15 - 29	90338-05M03	10 - 20	90445-11M01	21 - 6	92903-06100	7 - 34	92995-08100	15 - 33	93310-636U4	3 - 12
	15 - 35	90340-08002	17 - 9	90445-11M05	20 - 11		7 - 36		16 - 14	93310-730V8	3 - 26
90185-12058	11 - 28		18 - 9	90445-11M06	20 - 9		7 - 40		16 - 16	93310-835U8	3 - 15
90185-22043	13 - 19	90340-14M00	2 - 30	90464-12M00	8 - 6		11 - 32		16 - 19	93315-325V1	17 - 3
90201-03313	18 - 49	90385-12M04	7 - 27	90465-06M90	7 - 66	92903-06600	8 - 5	92995-10100	13 - 12		18 - 3
90201-05652	5 - 29	90386-06088	11 - 45		11 - 61		9 - 12	92995-12200	13 - 41	93317-325U0	17 - 53
90201-06416	10 - 17	90386-06M12	12 - 43	90467-06016	2 - 16		12 - 37	93101-25M03	17 - 28		18 - 61
90201-06M31	9 - 18	90386-07M58	12 - 53		2 - 19	92903-08100	7 - 31		17 - 54	93332-000U3	17 - 6
90201-08M13	12 - 16	90386-08006	12 - 53		3 - 8		12 - 46		18 - 29		18 - 6
90201-08M23	12 - 11	90386-08032	11 - 10	90467-08004	2 - 48	92903-08600	12 - 47		18 - 62	93332-000W7	17 - 8
90201-10008	2 - 10	90386-10009	11 - 37		6 - 5	92990-05100	4 - 16		23 - 14		18 - 8
90201-10120	11 - 38	90386-10M16	13 - 24		6 - 31		6 - 23	93102-30M05	3 - 3	93410-18M02	13 - 39
90201-10M02	11 - 8	90386-12089	11 - 24		6 - 35	92990-06100	9 - 3		22 - 15	93410-28M06	15 - 8
90201-11M22	15 - 28		12 - 12	90467-10M04	21 - 12		9 - 22	93102-36M02	3 - 13	93410-32M00	3 - 17
90201-12426	13 - 42	90386-13M38	10 - 5	90468-18008	7 - 69	92990-06200	9 - 21		22 - 14	93450-07M00	18 - 70
90201-12537	11 - 26	90386-18M21	13 - 37		12 - 9	92990-06600	9 - 4	93104-20M02	3 - 4	93501-04M02	12 - 48
90201-12M16	15 - 10	90386-18M35	13 - 38		12 - 41		11 - 43		22 - 16	93503-16003	18 - 44
90201-12M34	11 - 41		14 - 14		12 - 55		11 - 49	93106-09014	17 - 18	93515-32M01	11 - 36
90201-13M19	15 - 12	90386-18M63	14 - 13	90480-09M12	10 - 15	92990-08200	12 - 54		18 - 19	93603-12M11	18 - 45
90201-20417	3 - 25	90386-22M13	12 - 14	90480-09M25	9 - 14	92990-08600	11 - 56		23 - 8	93603-21111	3 - 24
90201-20M21	15 - 26	90386-22M15	13 - 17	90480-19M06	19 - 15	92990-10100	19 - 8	93210-04228	5 - 8	93604-10M03	17 - 33
90201-21M18	8 - 9	90386-30M60	15 - 6	90480-20M05	2 - 35	92990-10600	19 - 7		22 - 23		18 - 34
90201-22M67	13 - 18	90386-30M77	15 - 4	90501-10326	5 - 31	92990-12200	11 - 23	93210-04230	5 - 19	93606-12019	16 - 3
90201-30M00	15 - 2	90386-30M78	15 - 3	90501-12082	12 - 49	92995-06100	1 - 7		22 - 30		16 - 21
90202-03M51	14 - 6	90387-06119	7 - 46	90501-12M48	18 - 42		2 - 22	93210-07003	18 - 68		16 - 24
90202-07M07	12 - 40	90387-06M03	9 - 15	90501-14M08	15 - 19		4 - 9	93210-08287	20 - 14		16 - 29
90202-12060	19 - 3	90387-06M17	12 - 32	90501-16233	17 - 41		7 - 50		20 - 16		19 - 5
90202-12092	11 - 25	90387-06M69	10 - 16	90501-16M11	2 - 37		10 - 26	93210-15M52	21 - 11		23 - 19
	12 - 15	90387-08M05	7 - 28	90501-16M12	12 - 24		10 - 28	93210-29M94	15 - 5	93608-12063	2 - 7
90202-20M06	15 - 27	90387-08M16	12 - 13	90501-16M17	11 - 35		13 - 6	93210-32738	6 - 9	93700-06M03	11 - 17
90202-25M04	15 - 11	90387-10M02	13 - 28	90501-16M65	18 - 47	92995-06200	7 - 64		22 - 19		13 - 14
90206-10M04	12 - 33	90387-12M30	11 - 40	90501-23215	11 - 9	92995-06600	1 - 8	93210-46044	17 - 29	94702-00160	2 - 50
90206-12054	11 - 27	90389-25M00	19 - 19	90502-16M02	13 - 35		1 - 12		18 - 30	94702-00247	2 - 50
90206-13019	10 - 6	90430-08020	17 - 11	90506-08M23	7 - 56		1 - 14		23 - 12	95303-05700	12 - 20
90209-06M05	4 - 26		18 - 11	90506-14M24	13 - 29		3 - 10		23 - 33	95303-06600	7 - 41
90240-06M18	7 - 63		23 - 6	90508-12015	7 - 57		6 - 3	93210-46M16	3 - 14		7 - 44
90249-06M19	13 - 27	90430-12072	19 - 4	90508-29M05	12 - 17		6 - 29		22 - 13		7 - 52
90250-07M02	17 - 44		23 - 15	91490-16012	7 - 65		7 - 51	93210-49046	17 - 17		12 - 23
	18 - 52	90430-14115	2 - 31	91490-25012	11 - 44		7 - 60		18 - 18	95303-06700	2 - 14
90254-03003	11 - 13		22 - 8	91490-40025	19 - 21		8 - 15		23 - 7	95313-10600	2 - 11
90266-06009	1 - 9	90445-07260	2 - 15	91690-30012	12 - 3		9 - 7	93210-62269	3 - 5	95380-03600	6 - 19
90269-02M09	11 - 6	90445-07M00	2 - 17		13 - 34		9 - 10		22 - 17	95380-05600	12 - 26
90280-04M04	17 - 26	90445-07M23	2 - 18	91690-30020	13 - 26		10 - 14	93210-85M97	17 - 52		12 - 29
	18 - 27	90445-07M86	3 - 7		14 - 3		13 - 7		18 - 60	95380-06600	4 - 10
	23 - 36	90445-09090	6 - 4	92903-06100	4 - 18		17 - 20		23 - 13	95380-06700	9 - 20
90280-05015	8 - 7	90445-09097	6 - 32		6 - 13		18 - 21	93306-206U5	3 - 16	95380-08600	6 - 14
90282-04010	17 - 57	90445-09220	6 - 36		7 - 16	92995-08100	12 - 5	93306-207U0	17 - 49	95380-10600	16 - 25
	18 - 65	90445-09221	6 - 30		7 - 21		15 - 18		18 - 57		16 - 30

NUMERICAL INDEX
INDICE NUMERICO

PART NO. CODIGO N°	REF. NO.	PART NO. CODIGO N°	REF. NO.	PART NO. CODIGO N°	REF. NO.	PART NO. CODIGO N°	REF. NO.	PART NO. CODIGO N°	REF. NO.	PART NO. CODIGO N°	REF. NO.
95380-10600	23 - 21	97303-06025	7 - 22								
95380-12600	13 - 43	97513-08440	7 - 38								
95380-12800	15 - 15	97880-05020	4 - 15								
97013-06014	6 - 12	97880-06012	13 - 10								
97013-06016	9 - 11	97880-06040	9 - 2								
	11 - 31	97885-05012	11 - 19								
97013-06018	4 - 21	97885-06008	11 - 18								
97013-06020	12 - 36	97885-06012	11 - 62								
97013-06025	7 - 35	97885-06016	4 - 25								
97013-06030	4 - 17		15 - 22								
	7 - 39	97980-04114	5 - 17								
	8 - 4		22 - 29								
97013-06035	7 - 33	97980-05114	21 - 2								
97013-08012	7 - 68	97980-05310	5 - 25								
97013-08016	7 - 30	98503-05028	6 - 22								
97013-08030	12 - 45	98580-04008	5 - 12								
97075-08025	15 - 17	98780-04015	2 - 24								
	16 - 15	99001-08600	17 - 60								
97075-08030	16 - 13		18 - 69								
97075-08035	15 - 32										
	16 - 18										
97075-10040	19 - 6										
97080-06010	14 - 11										
97080-06035	11 - 53										
97095-06010	8 - 14										
	13 - 31										
97095-06012	2 - 21										
	7 - 59										
97095-06016	1 - 11										
	10 - 13										
	13 - 5										
	17 - 19										
	18 - 20										
97095-06018	1 - 6										
97095-06020	1 - 13										
	3 - 9										
	6 - 2										
	7 - 49										
	9 - 6										
	9 - 9										
	10 - 25										
97095-06030	10 - 18										
	10 - 27										
97095-06040	6 - 28										
97095-08016	12 - 4										
97095-08045	12 - 10										
97095-10045	13 - 11										
97303-06016	7 - 17										