

PARTS CATALOGUE

EK8DMH'05 (6804)



1D680-200E1

(2D680-200E1)

FOREWORD

This Parts Catalogue is related to the parts for the model(s) on the cover page. When you are ordering replacement parts, please refer to this Parts Catalogue and quote both part numbers and part names correctly.

1. Modifications or additions which have been made after the issue of the Parts Catalogue will be announced in the Parts News.
It is advisable that you make the necessary corrections to the Parts Catalogue according to the Parts News.

2. Abbreviations

The following abbreviations are used in this Parts Catalogue.

- “UR” Use specified parts number.
- “UN” Use as many as needed.
- “AP” Alternate Parts
- “LM” Locally Made (Parts need to be ordered locally)
- “F#” Frame No. (Applicable machine No.)
- “O/S” Over Size

3. The number of components for assembly

- Parts, which are to be supplied in an assembly, are listed with a dot (.) in front of the part name as shown below.
- The numeral appearing to the right of each component part indicates the quantity of parts for each assembly unit.

PART NO.	DESCRIPTION	Q'TY	REMARKS
2F5-83310-60	FRONT FLASHER LIGHT ASSY	2	
115-83311-60	.BULB (6V-18W)	1	

4. Applicable colours of graphics are represented in the “REMARKS” as shown below.

PART NO.	DESCRIPTION	Q'TY	REMARKS
2N4-24110-00-X5	FUEL TANK COMP.	2	MXR
3J1-24240-10	.GRAPHIC, FUEL TANK	1	FOR MXR

5. Note that the illustrations for reference in finding parts numbers are not to be used for assembling. When assembling, please use the applicable service manual.

6. The asterisk (*) before a reference number indicates modified items after the first edition.

7. Applicable Serial No.

Engine Serial No.

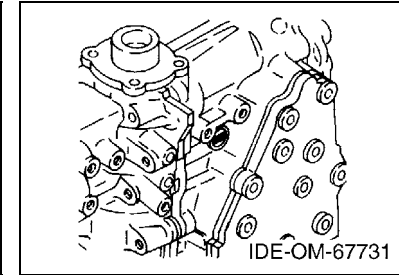
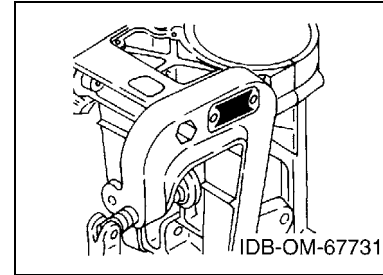

8. Applicable Engine Starting Serial No.

Model	Serial No.	Model	Serial No.
EK8D	680K-1002012		

9. Applicable Colour Code

Abbreviation	Colour Name	Colour Code
DBNM2	DARK BLUISH GRAY METALLIC 2	004D

10. Quantity Column Information

Column No.	Name Of Q'ty Column	Applicable Model
1	6804	EK8DMH

CONTENTS

TOP COWLING	A4
CYLINDER & CRANKCASE	A5
CRANKSHAFT & PISTON	A7
INTAKE	B1
CARBURETOR	B2
FUEL 1	B4
FUEL 2	B6
STARTER	B7
GENERATOR	C2
ELECTRICAL	C3
CONTROL	C4
REMO CON ATTACHMENT	C7
BRACKET	D1
UPPER CASING	D4
LOWER CASING & DRIVE 1	D5
LOWER CASING & DRIVE 2	E1
FUEL TANK	E2
OPTIONAL PARTS	E3
REPAIR KIT 1	E4
REPAIR KIT 2	E6

INDEX

NUMERICAL INDEX	G1
-----------------------	----

FIG. 1 TOP COWLING

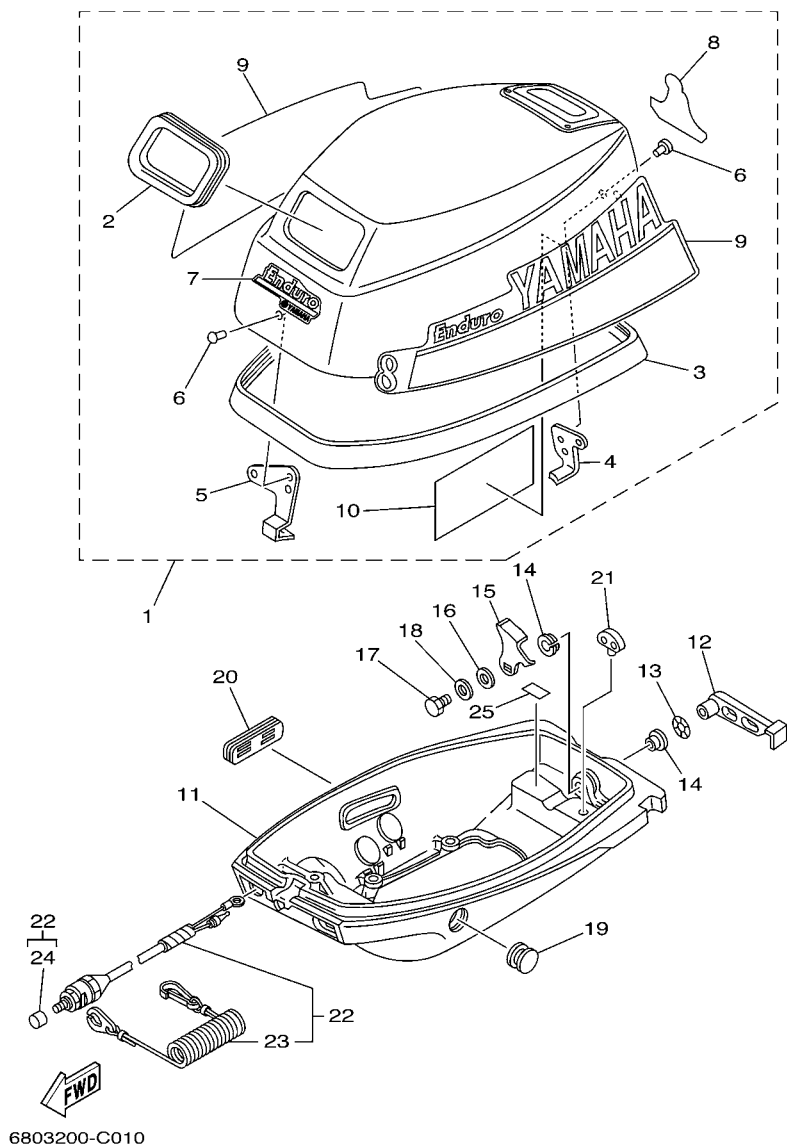

REF. NO.	PART NO.	DESCRIPTION	6804				REMARKS
1	680-42610-L1-4D	TOP COWLING ASSY	1				
2	677-15761-01	.SEAL, RUBBER 1	1				
3	6G1-42615-00	.SEAL	1				
4	677-42647-00	.HOLDER, CLAMP BAND	1				
5	677-42651-02	.HOOK	1				
6	90266-04M04	.RIVET	4				
7	677-42677-J0	.GRAPHIC, FRONT	1				
8	680-42678-K0	.GRAPHIC, REAR	1				
9	677-W0070-H0	.GRAPHIC SET	1				
10	6B8-13437-00	.MARK, CAUTION	1				
11	680-42711-70-4D	COWLING, BOTTOM	1				
12	677-42815-00-4D	LEVER, CLAMP	1				
13	90206-12052	WASHER, WAVE	1				
14	90386-12069	BUSH	2				
15	656-42816-00	LEVER, CLAMP	1				
16	90201-06068	WASHER, PLATE	1				
17	97095-06012	BOLT	1				
18	92995-06600	WASHER	1				
19	677-42724-00	GROMMET	1				
20	677-42725-00	GROMMET	1				
21	606-42591-00	HOLDER, SHEAR PIN	1				
22	677-82575-20	ENGINE STOP SWITCH ASSY	1				
23	682-82556-00	.STOPPER	1				
24	689-8257Y-00	.CAP	1				
25	669-42791-00	MARK 1	1				

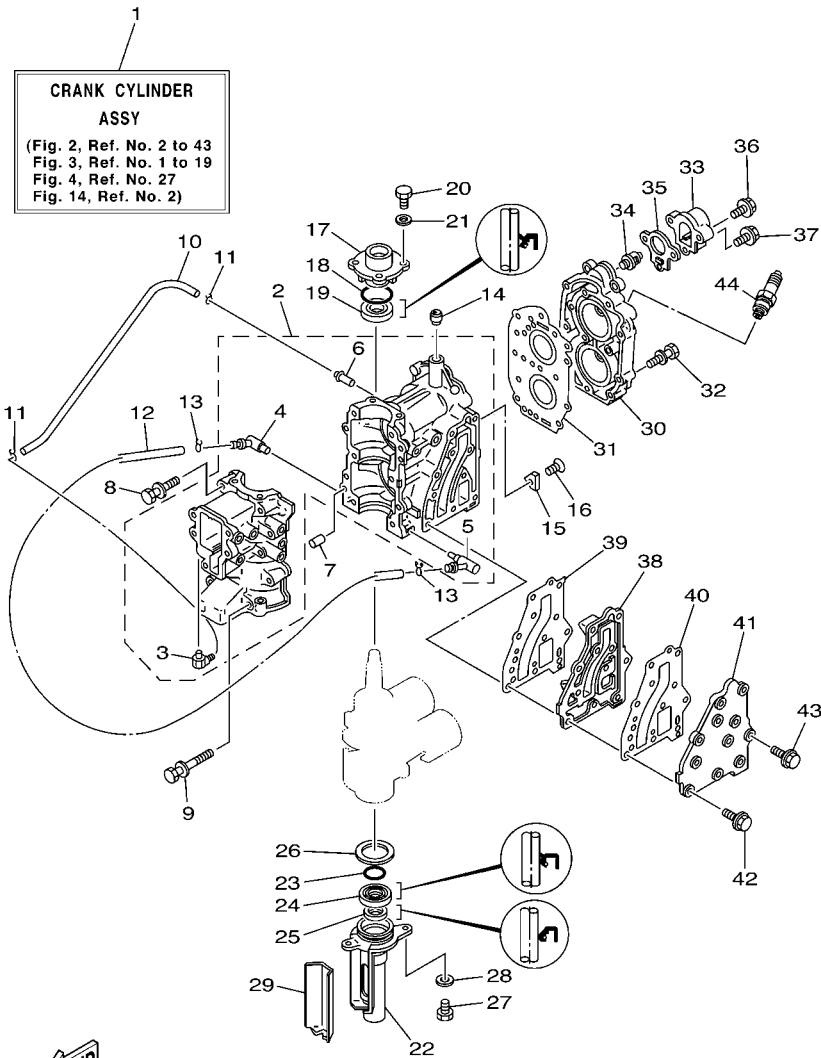

6803200-C020

FIG. 2 CYLINDER & CRANKCASE

REF. NO.	PART NO.	DESCRIPTION	6804				REMARKS
1	680-W0090-65-1S	CRANK CYLINDER ASSY	1				
2	680-15100-03-1S	CRANKCASE ASSY	1				
3	650-11370-01	.CHECK VALVE ASSY	1				
4	677-11372-00	.NIPPLE, HOSE	1				
5	676-11372-00	.NIPPLE, HOSE	1				
6	624-14485-00	.PIPE, JOINT	1				
7	93605-08041	PIN, DOWEL	2				
8	90119-06M15	BOLT, WITH WASHER	8				
9	90119-06M16	BOLT, WITH WASHER	2				
10	90445-07M02	HOSE (L167)	1				
11	90467-06016	CLIP	2				
12	90445-10M03	HOSE (L240)	1				
13	90467-09M09	CLIP	2				
14	99530-10014	PIN, DOWEL	1				
15	664-11325-00	ANODE	1				
16	90151-06M01	SCREW, COUNTERSUNK	1				
17	677-15359-00-94	HOUSING, OIL SEAL	1				
18	93210-42159	O-RING	1				
19	93102-20M25	OIL SEAL	1				
20	97095-06018	BOLT	4				
21	92995-06600	WASHER	4				
22	677-15396-01-5B	HOUSING, OIL SEAL	1				
23	93210-42M70	O-RING	1				
24	93101-20M29	OIL SEAL	1				
25	93101-14M01	OIL SEAL	1				
26	90201-41303	WASHER, PLATE	1				
27	97095-06016	BOLT	2				

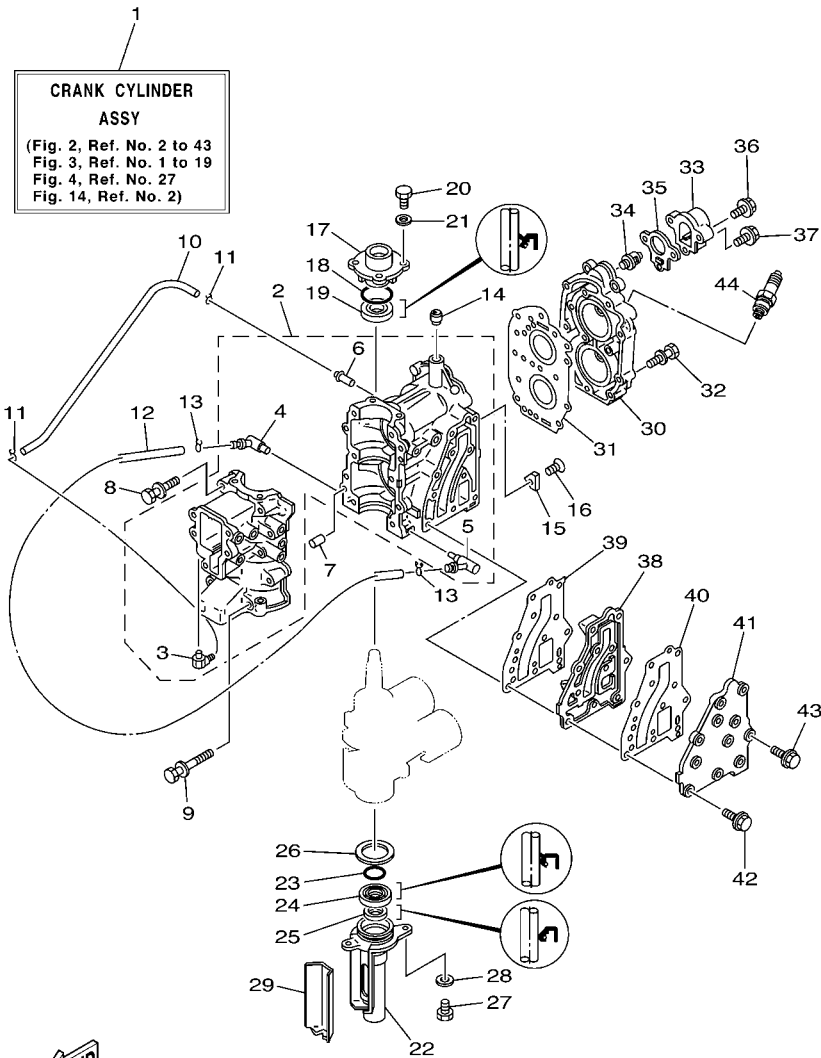

6803200-C020

FIG. 2 CYLINDER & CRANKCASE

REF. NO.	PART NO.	DESCRIPTION	6804				REMARKS
28	92995-06600	WASHER	2				
29	680-15379-01	SEAL, CRANKCASE	1				
30	680-11111-00-1S	HEAD, CYLINDER 1	1				
31	677-11181-A1	GASKET, CYLINDER HEAD 1	1				
32	90119-06048	BOLT, WITH WASHER	13				
33	677-12413-00-1S	COVER, THERMOSTAT	1				
34	6E5-12411-02	THERMOSTAT	1				
35	677-12414-A1	GASKET, COVER	1				
36	90119-06MA3	BOLT, WITH WASHER	1				
37	90119-06047	BOLT, WITH WASHER	2				
38	677-41111-01-1S	INNER COVER, EXHAUST	1				
39	677-41112-A1	GASKET, EXHAUST INNER COVER	1				
40	677-41114-A1	GASKET, EXHAUST OUTER COVER	1				
41	677-41113-01-1S	OUTER COVER, EXHAUST	1				
42	90119-06MA4	BOLT, WITH WASHER	10				
43	90119-06023	BOLT, WITH WASHER	1				
44	94702-00039	PLUG, SPARK (NGK B6HS)	2				

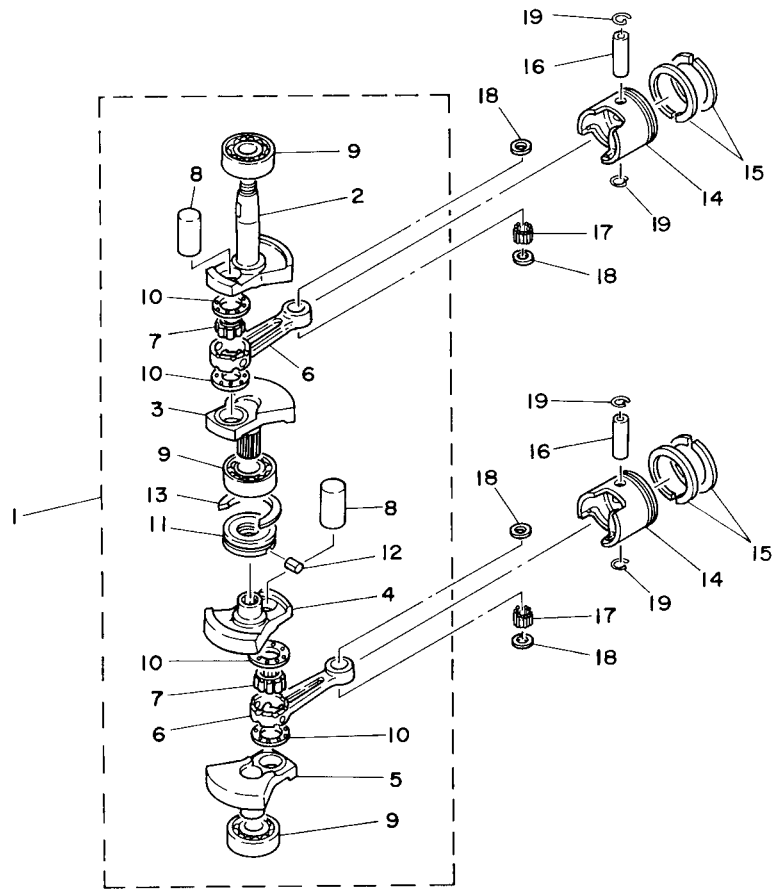

6801200-2030

FIG. 3 CRANKSHAFT & PISTON

REF. NO.	PART NO.	DESCRIPTION	6804				REMARKS
1	680-11400-02	CRANKSHAFT ASSY	1				
2	677-11412-02	.CRANK 1	1				
3	677-11422-02	.CRANK 2	1				
4	677-11432-02	.CRANK 3	1				
5	677-11442-02	.CRANK 4	1				
6	680-11651-02	.ROD, CONNECTING	2				
7	93310-418U1	.BEARING	2				
8	6G1-11681-00	.PIN, CRANK 1	2				
9	93306-204U0	.BEARING	3				
10	90209-18112	.WASHER	4				
11	677-11515-01	.SEAL, LABYRINTH 1	1				
12	91690-30010	.PIN, SPRING	1				
13	93440-47055	.CIRCLIP	1				
14	677-11631-00-97	PISTON (STD)	2				
	677-11635-00	PISTON (0.25MM O/S)	2				AP
	677-11636-00	PISTON (0.50MM O/S)	2				AP
15	647-11610-00	PISTON RING SET (STD)	2				
	647-11610-10	PISTON RING SET (0.25MM O/S)	2				AP
	647-11610-20	PISTON RING SET (0.50MM O/S)	2				AP
16	6G1-11633-00	PIN, PISTON	2				
17	93602-14118	PIN, DOWEL	56				
18	90201-12565	WASHER, PLATE	4				
19	93450-13022	CIRCLIP	4				

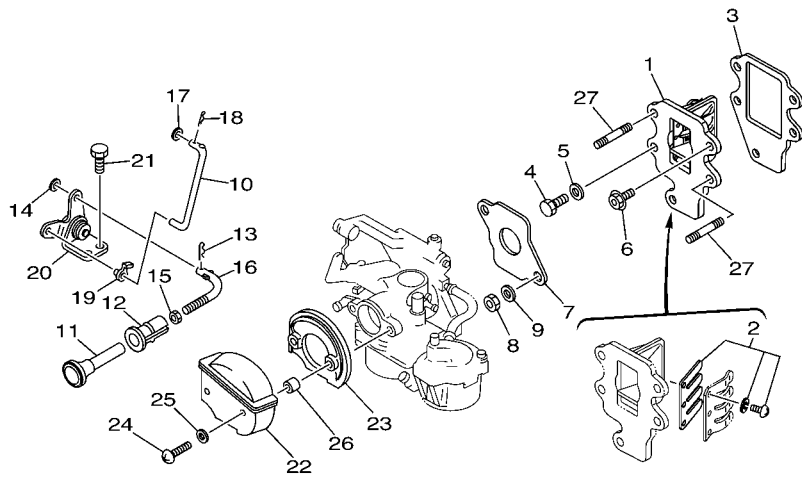

FWD
6803200-C040

FIG. 4 INTAKE

REF. NO.	PART NO.	DESCRIPTION	6804				REMARKS
1	680-13610-00	REED VALVE ASSY	1				
2	680-W0004-00	.REED SET	1				
3	677-13621-A1	GASKET, VALVE SEAT	1				
4	97013-06018	BOLT	2				
5	92903-06600	WASHER, PLATE	2				
6	90119-06M69	BOLT, WITH WASHER	1				
7	650-14198-A1	GASKET	1				
8	95380-06700	NUT	2				
9	92995-06600	WASHER	2				
10	680-41256-00	ROD, CHOKE 1	1				
11	677-41271-00	KNOB, CHOKE	1				
12	90480-14M02	GROMMET	1				
13	90468-10004	CLIP	1				
14	92990-04600	WASHER, PLATE	1				
15	95380-04700	NUT	1				
16	680-41257-00	ROD, CHOKE 2	1				
17	92990-03600	WASHER	1				
18	90468-10004	CLIP	1				
19	661-41262-02	JOINT, CHOKE LEVER	1				
20	680-41201-00	CHOKE LINK ASSY	1				
21	97095-06012	BOLT	1				
22	680-14431-00	SILENCER, INTAKE 1	1				
23	680-14441-00	SILENCER, INTAKE 2	1				
24	97880-05025	SCREW, PAN HEAD	2				
25	92990-05600	WASHER, PLATE	2				
26	90387-05M09	COLLAR	2				
27	90116-06123	BOLT, STUD	2				

B1

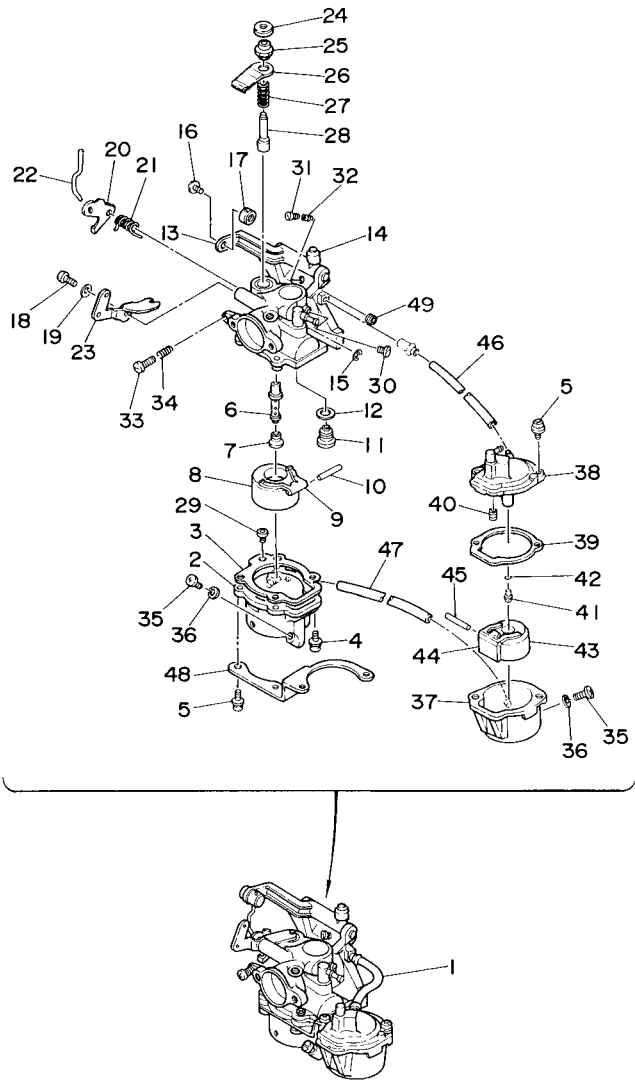

6801200-4050

FIG. 5 CARBURETOR

REF. NO.	PART NO.	DESCRIPTION	6804				REMARKS
1	680-14301-02	CARBURETOR ASSY 1	1				
2	680-14381-20	.BODY, FLOAT CHAMBER	1				
3	650-14384-00	.GASKET, FLOAT CHAMBER	1				
4	97980-04112	.SCREW, WITH WASHER	2				
5	97980-04115	.SCREW, WITH WASHER	4				
6	680-14341-00	.NOZZLE, MAIN	1				
7	648-14343-34	.JET, MAIN (# 68)	1				
8	647-14385-00	.FLOAT	1				
9	626-14387-90	.ARM, FLOAT	1				
10	626-14386-00	.PIN, FLOAT	1				
11	677-14390-12	.NEEDLE VALVE ASSY	1				
12	626-14398-00	.GASKET	1				
13	680-41216-00	.SHEAVE SHAFT, ACCEL. LINK	1				
14	626-42658-00	.BUSHING	1				
15	93430-04301	.CIRCLIP	1				
16	677-14327-01	.SCREW	1				
17	677-41226-00	.END, THROTTLE LEVER	1				
18	650-14327-01	.SCREW	1				
19	650-14349-00	.PIPE	1				
20	680-14315-00	.LEVER, THROTTLE 1	1				
21	648-14331-00	.SPRING, THROTTLE VALVE	1				
22	680-41241-00	.ROD, LINK	1				
23	626-14376-00	.LEVER, STARTER 2	1				
24	626-14373-00	.COVER, PLUNGER CAP	1				
25	626-14374-00	.CAP, PLUNGER	1				
26	626-14378-00	.PLATE, STARTER LEVER 1	1				
27	626-14335-00	.SPRING, PLUNGER	1				

FIG. 5 CARBURETOR

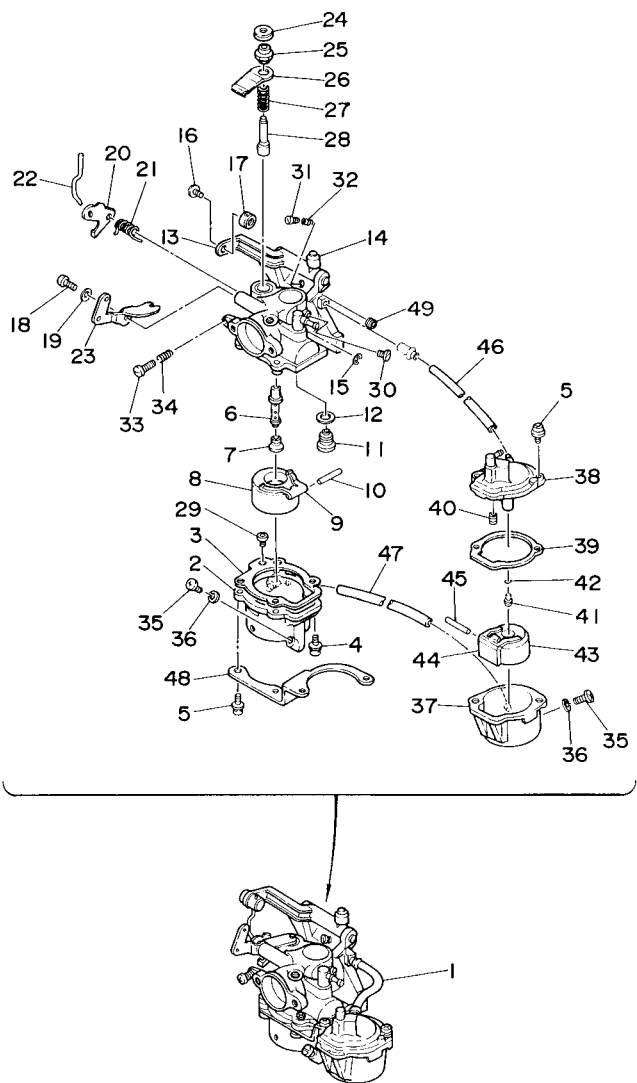

REF. NO.	PART NO.	DESCRIPTION	6804				REMARKS
28	626-14371-00	.PLUNGER, STARTER	1				
29	648-14344-35	.JET, STARTER (# 70)	1				
30	648-14342-24	.JET, PILOT (# 48)	1				
31	647-14323-00	.SCREW, AIR ADJUSTING	1				
32	646-14212-01	.SPRING, PILOT ADJUSTING	1				
33	650-14321-01	.SCREW, THROTTLE	1				
34	626-14333-00	.SPRING, THROTTLE STOP	1				
35	97890-04005	.SCREW, PAN HEAD	2				
36	6L2-14398-00	.GASKET	2				
37	680-14181-00	.BODY, FLOAT CHAMBER 1	1				
38	680-14182-00	.COVER, FLOAT CHAMBER	1				
39	652-14384-00	.GASKET, FLOAT CHAMBER	1				
40	6F5-14392-00	.VALVE, NEEDLE	1				
41	652-14353-25	.JET, PILOT (# 50)	1				
42	652-14147-00	.O-RING	1				
43	652-14385-00	.FLOAT	1				
44	652-14387-40	.ARM, FLOAT	1				
45	652-14386-00	.PIN, FLOAT	1				
46	652-14348-00	.PIPE 1	1				
47	680-14348-00	.PIPE 1	1				
48	680-14346-00	.PLATE	1				
49	647-14342-55	.JET, PILOT (#110)	1				

FWD
6801200-4050

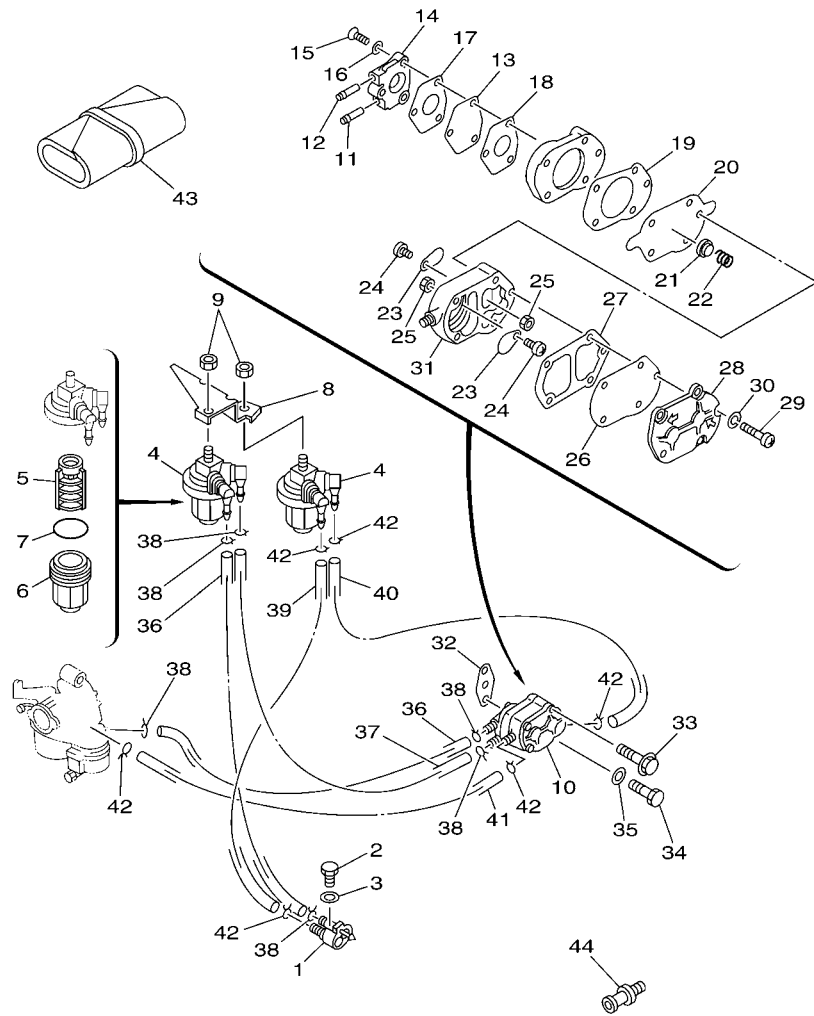

6804200-D060

FIG. 6 FUEL 1

REF. NO.	PART NO.	DESCRIPTION	6804				REMARKS
1	680-24304-01	FUEL PIPE JOINT COMP. 1	1				
2	97095-06020	BOLT	1				
3	92995-06600	WASHER	1				
4	61N-24560-00	FILTER ASSY	2				
5	61N-24563-00	.ELEMENT, FILTER	1				
6	61N-24521-00	.CUP, FILTER	1				
7	93210-32738	.O-RING	1				
8	680-24566-01	BRACKET, FILTER	1				
9	95380-08600	NUT	2				
10	6A4-24410-06	FUEL PUMP ASSY	1				
11	652-24461-00	.PIPE, JOINT	1				
12	62C-24461-00	.PIPE, JOINT	1				
13	652-24471-10	.DIAPHRAGM	1				
14	652-24415-01	.BODY 4	1				
15	98780-04010	.SCREW, FLAT HEAD	3				
16	92990-04500	.WASHER	3				
17	6A4-24471-00	.DIAPHRAGM	1				
18	652-24432-00	.GASKET, FUEL PUMP 2	1				
19	648-24434-01	.GASKET, BODY	1				
20	648-24411-00	.DIAPHRAGM	1				
21	648-24424-00	.SEAT, SPRING	1				
22	648-24423-00	.SPRING, DIAPHRAGM	1				
23	6A0-24421-01	.VALVE, CHECK	2				
24	6A0-14325-00	.SCREW, PAN HEAD	2				
25	95380-03600	.NUT	2				
26	663-24411-00	.DIAPHRAGM	1				
27	648-24435-02	.GASKET, BODY 2	1				

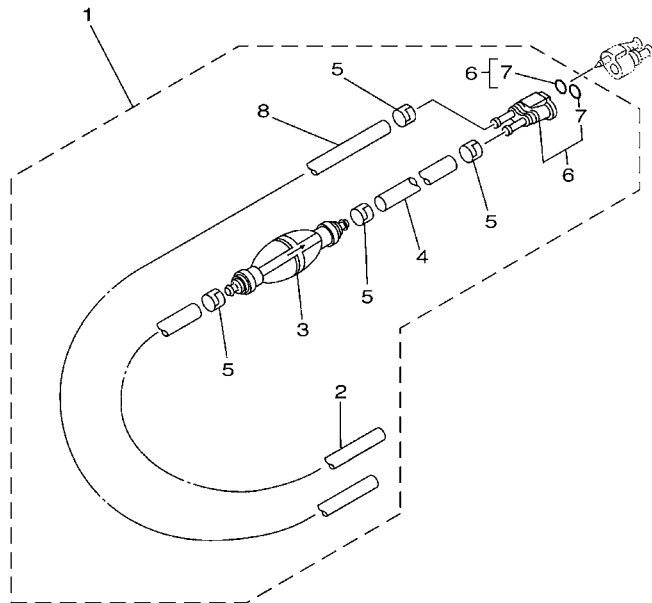

6801200-2070

FIG. 7 FUEL 2

REF. NO.	PART NO.	DESCRIPTION	6804				REMARKS
1	6Y3-24306-04	FUEL PIPE COMP. 1	1				AP FOR LKA
2	90445-11M06	.HOSE (L2050)	1				
3	61J-24360-00	.PRIMER PUMP ASSY	1				
4	90445-11M05	.HOSE (L850)	1				
5	650-24351-01	.BAND 1	4				
6	680-24305-01	.FUEL PIPE JOINT COMP. 2	1				
7	93210-08287	..O-RING	2				
8	90445-11M81	.HOSE (L3000)	1				

FIG. 8 STARTER

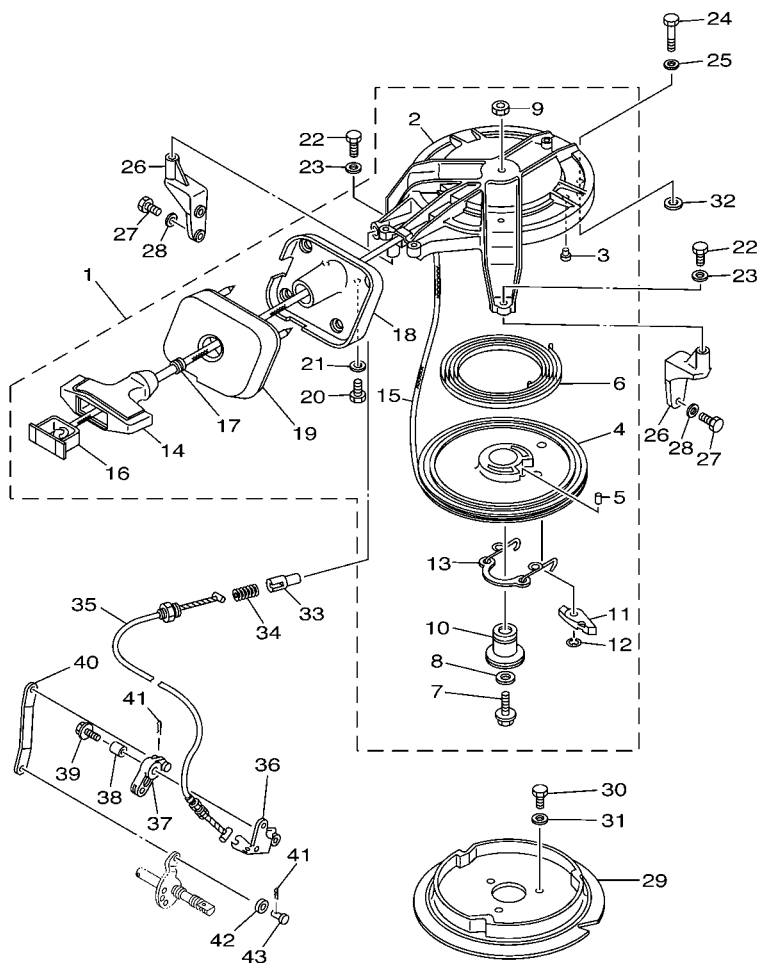

6803200-C080

*1: CUT FROM 50M ROLLS, PART NO.90890-44373, CUTTING LENGTH 1.65M

REF. NO.	PART NO.	DESCRIPTION	6804				REMARKS
1	677-15710-05-94	STARTER ASSY	1				
2	682-15711-71-94	.CASE, STARTER	1				
3	648-15773-00	.STAY 3	1				
4	677-15714-00-94	.DRUM, SHEAVE	1				
5	91690-40020	.PIN, SPRING	1				
6	90510-08M04	.SPRING, SPIRAL	1				
7	90119-06M34	.BOLT, WITH WASHER	1				
8	90201-06060	.WASHER, PLATE	1				
9	95303-06600	.NUT	1				
10	677-15717-01	.SHAFT, STARTER	1				
11	677-15741-01	.PAWL, DRIVE	1				
12	93430-06M02	.CIRCLIP	1				
13	677-15705-02	.SPRING, DRIVE PAWL	1				
14	689-15755-01	.HANDLE, STARTER	1				
15	*	.WIRE (L1650)	1				*1
16	6F5-15779-02	.COVER	1				
17	6A0-15789-00	.DAMPER	1				
18	677-15758-01-94	.GUIDE, ROPE	1				
19	677-15762-00	.SEAL, RUBBER 2	1				
20	97095-06016	.BOLT	2				
21	92995-06600	.WASHER	2				
22	97095-06020	BOLT	2				
23	92995-06600	WASHER	2				
24	97095-06035	BOLT	1				
25	92995-06600	WASHER	1				
26	6K3-15771-00-94	STAY 1	2				
27	97095-06018	BOLT	4				

FIG. 8 STARTER

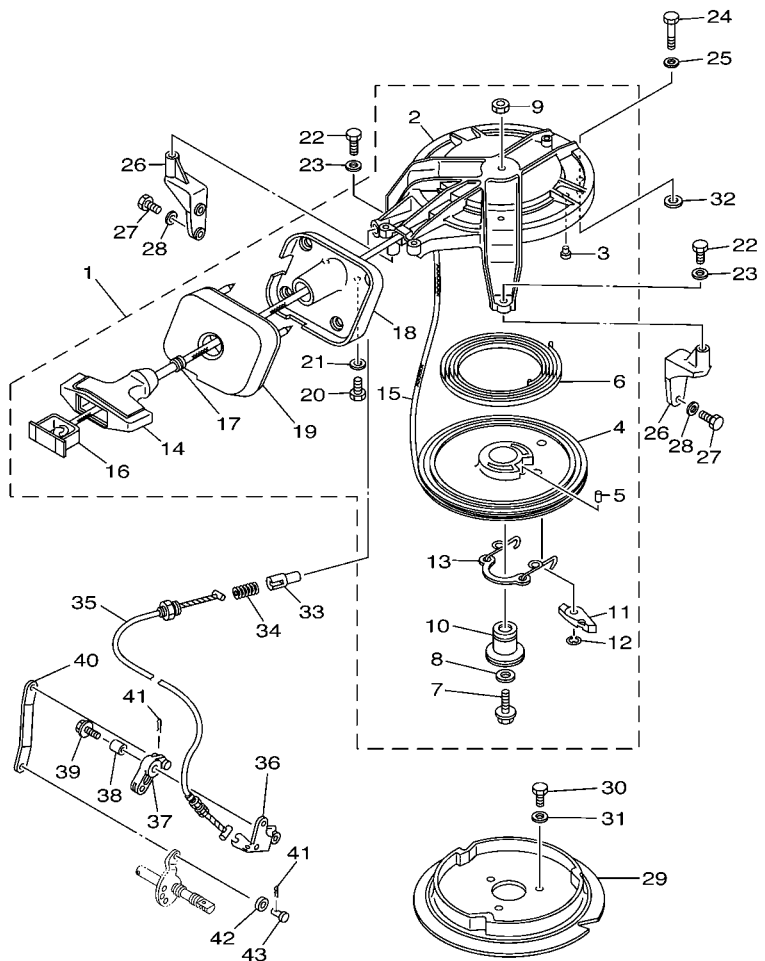

REF. NO.	PART NO.	DESCRIPTION	6804				REMARKS
28	92995-06600	WASHER	4				
29	6E7-15723-00-94	PULLEY, STARTER	1				
30	97095-06012	BOLT	3				
31	92995-06600	WASHER	3				
32	90201-10120	WASHER, PLATE	1				
33	656-15748-00	PLUNGER, STARTER STOP	1				
34	90501-10227	SPRING, COMPRESSION	1				
35	677-15770-01	CABLE COMP., STARTER STOP	1				
36	677-15772-00	STAY 2	1				
37	677-15746-00	ARM	1				
38	90387-06504	COLLAR	1				
39	90119-06M87	BOLT, WITH WASHER	1				
40	677-15747-00	LINK	1				
41	90468-10005	CLIP	2				
42	90202-05088	WASHER, PLATE	1				
43	647-41652-00	SET PIN	1				

 6803200-C080

*1: CUT FROM 50M ROLLS, PART NO.90890-44373, CUTTING LENGTH 1.65M



6770010-0080

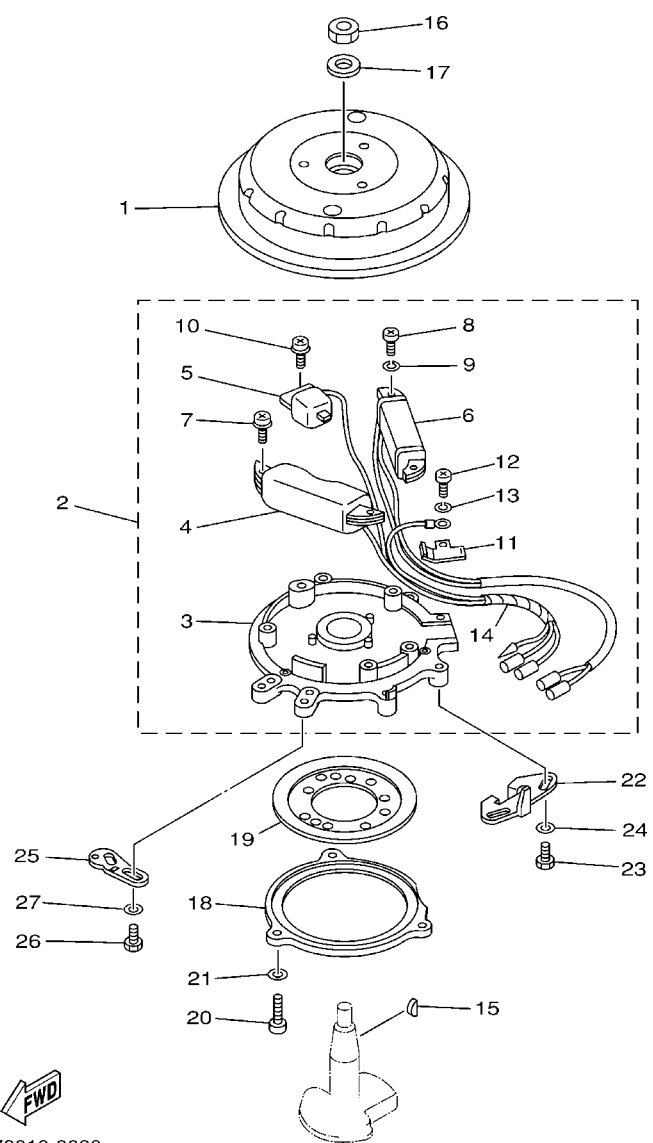
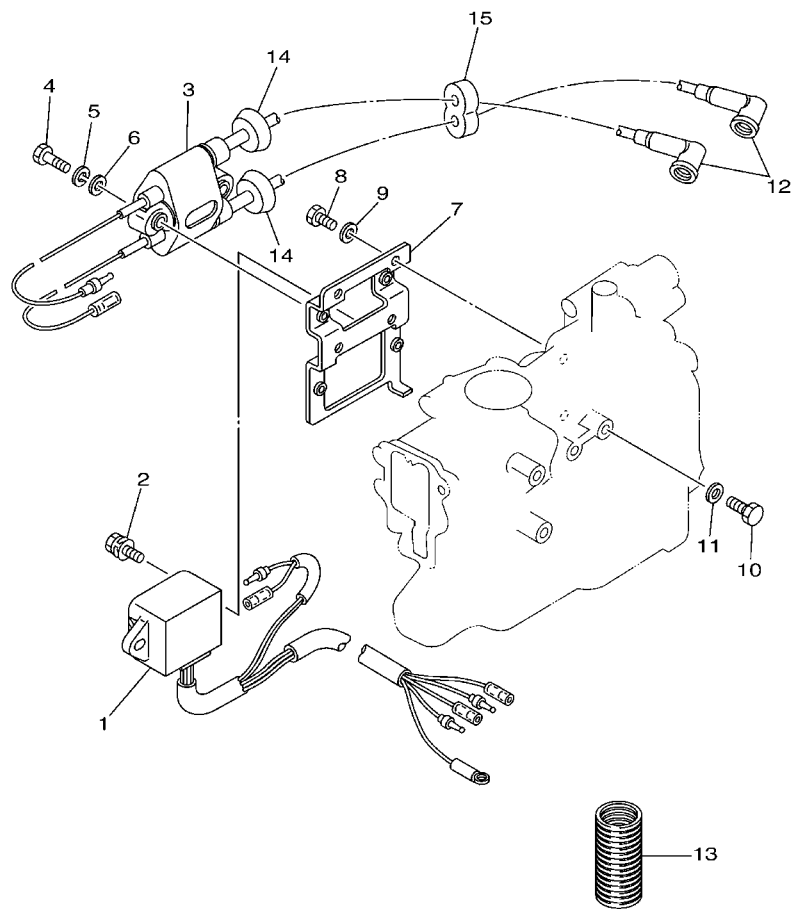

FIG. 9 GENERATOR

REF. NO.	PART NO.	DESCRIPTION	6804				REMARKS
1	6G1-85550-71	ROTOR ASSY	1				
2	6K3-85560-40	BASE ASSY	1				
3	6K3-85509-70	.BASE, MAGNETO	1				
4	6E7-85520-70	.COIL, CHARGE	1				
5	6E7-85580-70	.COIL, PULSER	1				
6	6E7-85533-40	.COIL, LIGHTING	1				
7	90159-05039	.SCREW, WITH WASHER	2				
8	97802-05020	.SCREW, PAN HEAD	2				
9	92902-05100	.WASHER, SPRING	2				
10	90159-05038	.SCREW, WITH WASHER	1				
11	6G1-85548-70	.HOLDER	2				
12	97802-04008	.SCREW, PAN HEAD	1				
13	92902-04100	.WASHER, SPRING	1				
14	6G1-85515-70	.LEAD WIRE ASSY	1				
15	90280-04M06	KEY, WOODRUFF	1				
16	90170-10113	NUT	1				
17	90201-10126	WASHER, PLATE	1				
18	677-41611-00-94	RETAINER, MAGNETO BASE	1				
19	677-41612-00	RETAINER, MAGNETO BASE	1				
20	97885-05010	SCREW, PAN HEAD	3				
21	92995-05600	WASHER	3				
22	680-41615-10	STOPPER, MAGNETO BASE	1				
23	97095-06016	BOLT	2				
24	92995-06600	WASHER	2				
25	680-41213-00-94	CAM, ACCEL.	1				
26	97095-05014	BOLT	2				
27	92995-05600	WASHER	2				



6801200-2100

FIG. 10 ELECTRICAL

REF. NO.	PART NO.	DESCRIPTION	6804				REMARKS
1	680-85540-01	C.D.I. UNIT ASSY	1				
2	90119-06M20	BOLT, WITH WASHER	2				
3	680-85570-00	IGNITION COIL ASSY	1				
4	97095-06025	BOLT	2				
5	92995-06100	WASHER, SPRING	2				
6	92995-06600	WASHER	2				
7	680-85542-00	BRACKET	1				
8	97095-06014	BOLT	4				
9	92995-06600	WASHER	4				
10	97095-06014	BOLT	1				
11	92995-06600	WASHER	1				
12	682-82370-00	PLUG CAP ASSY	2				
13	6K3-83557-00	TUBE	1				
14	90480-25161	GROMMET	2				
15	90480-25M18	GROMMET	1				

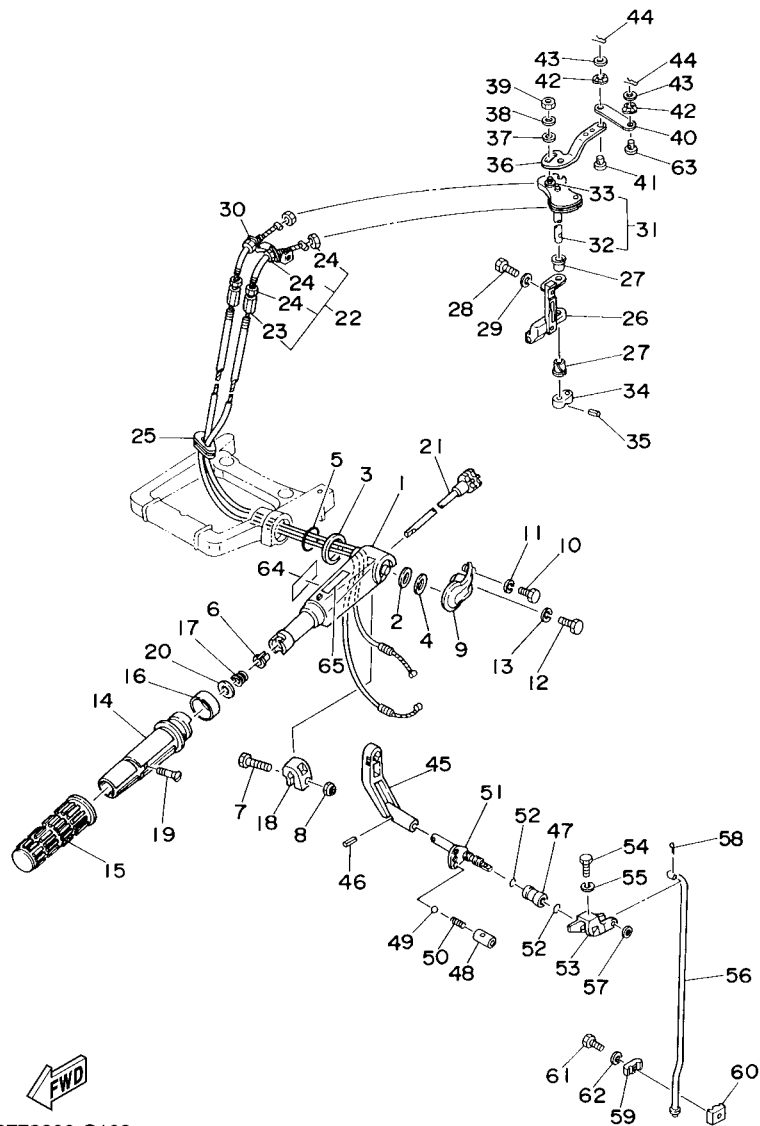

 6773200-C100

FIG. 11 CONTROL

REF. NO.	PART NO.	DESCRIPTION	6804				REMARKS
1	647-42111-02-4D	HANDLE, STEERING	1				
2	90560-12075	SPACER	1				
3	90560-30085	SPACER	1				
4	90560-12141	SPACER	1				
5	93210-25032	O-RING	1				
6	90386-08032	BUSH	1				
7	97095-06020	BOLT	1				
8	90185-06062	NUT, SELF-LOCKING	1				
9	677-42112-00-4D	HANDLE, STEERING	1				
10	97095-06020	BOLT	1				
11	92995-06600	WASHER	1				
12	97095-06040	BOLT	1				
13	92995-06600	WASHER	1				
14	647-42119-02	GRIP, STEERING HANDLE	1				
15	647-42177-00	RUBBER, HANDLE	1				
16	680-42137-00	INDICATOR, THROTTLE	1				
17	90501-23215	SPRING, COMPRESSION	1				
18	656-42126-01	FRICITION, STEERING HANDLE GRIP	1				
19	90149-05M13	SCREW	1				
20	92903-10600	WASHER, PLATE	1				
21	655-42138-01	LEVER, THROTTLE	1				
22	677-26301-02	THROTTLE CABLE ASSY	2				
23	90179-06045	.NUT	1				
24	90170-06011	.NUT	3				
25	90480-16M03	GROMMET	1				
26	677-41661-00-94	BRACKET	1				
27	90386-08032	BUSH	2				

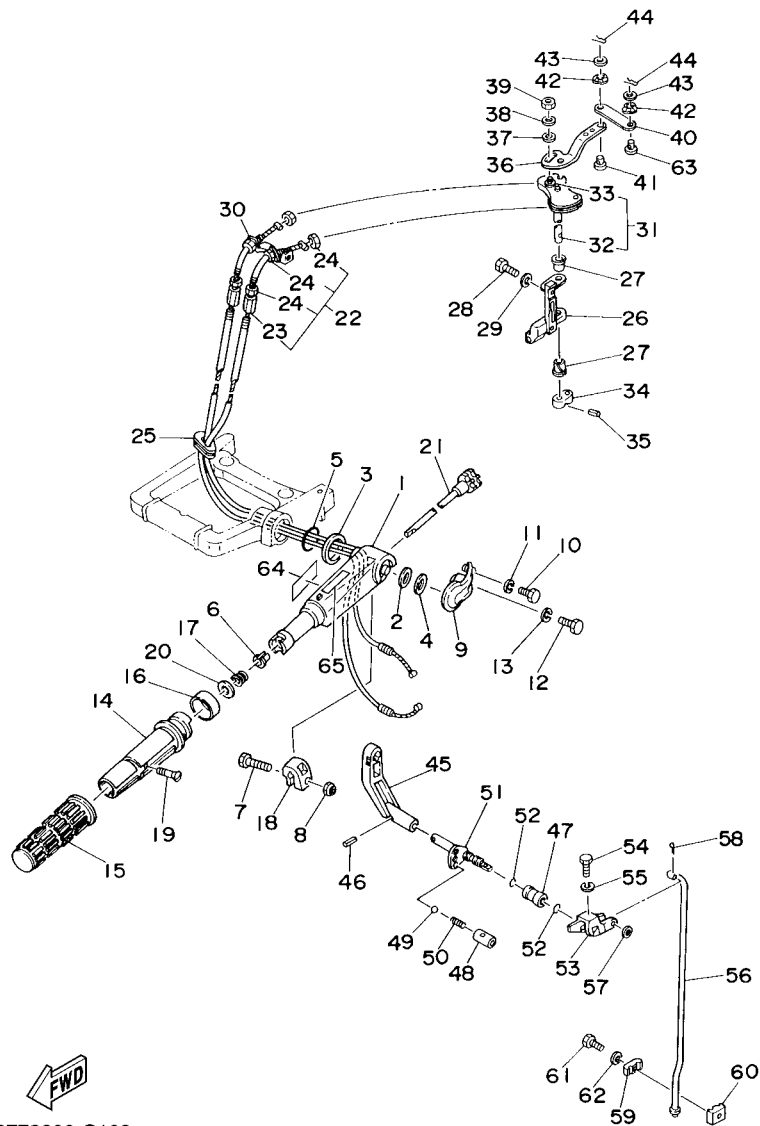

6773200-C100

FIG. 11 CONTROL

REF. NO.	PART NO.	DESCRIPTION	6804				REMARKS
28	97095-06035	BOLT	2				
29	92995-06600	WASHER	2				
30	655-14497-01	STAY, THROTTLE WIRE	1				
31	655-41638-01	PULLEY	1				
32	655-41635-00	.SHAFT, LINK CONNECTING	1				
33	650-41641-00	.BOSS, LEVER	1				
34	655-48541-00-4D	STAY	1				
35	90254-03003	PIN, SPRING	1				
36	677-41631-00	LEVER, MAGNETO CONTROL	1				
37	92990-06600	WASHER, PLATE	1				
38	92990-06100	WASHER, SPRING	1				
39	95380-06600	NUT, HEXAGON	1				
40	677-41632-00	LEVER, MAGNETO CONTROL	1				
41	647-41652-00	SET PIN	1				
42	90206-05005	WASHER, WAVE	2				
43	92990-05200	WASHER, PLAIN	2				
44	90468-10005	CLIP	2				
45	655-44111-02-4D	HANDLE, GEAR SHIFT	1				
46	91690-40016	PIN, SPRING	1				
47	655-44122-03	BUSHING, SHIFT ROD LEVER	1				
48	655-42715-00	BUSHING	1				
49	93505-16024	BALL	1				
50	90501-12274	SPRING, COMPRESSION	1				
51	677-44119-00	SHAFT, CHANGE	1				
52	93210-09165	O-RING	2				
53	655-44121-01	LEVER, SHIFT ROD	1				
54	97090-05020	BOLT	1				



6773200-C100

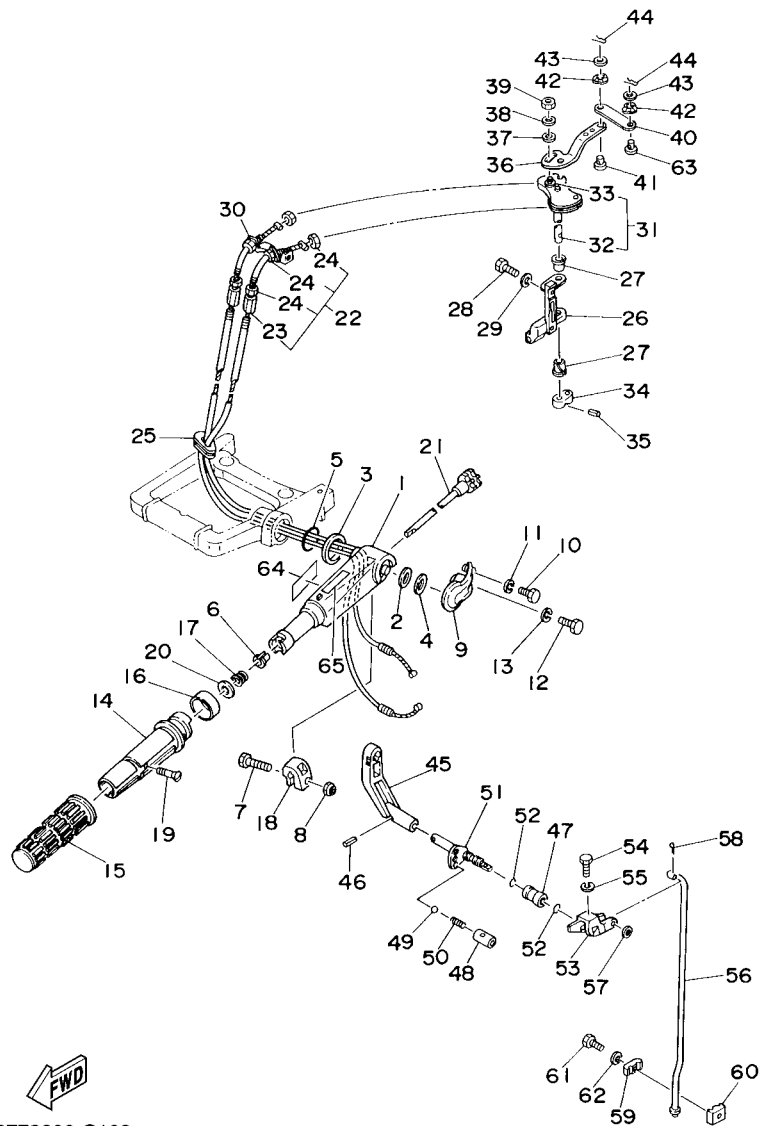
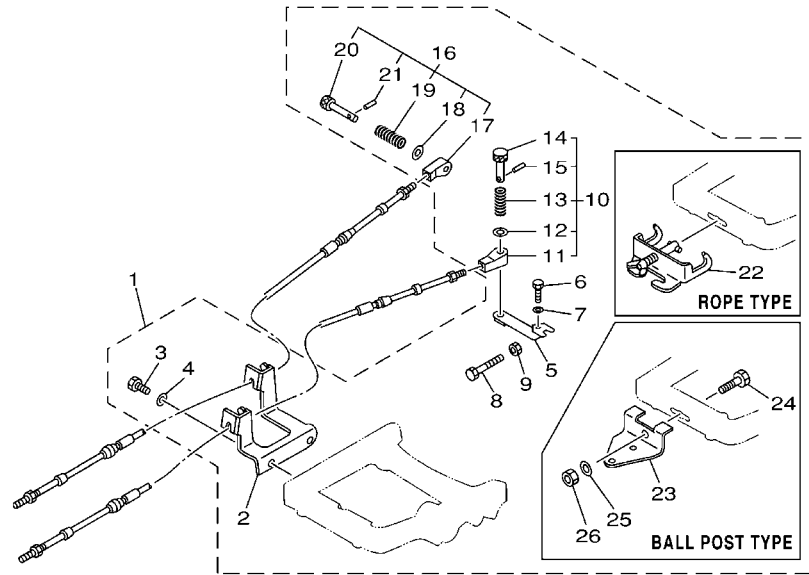

FIG. 11 CONTROL

REF. NO.	PART NO.	DESCRIPTION	6804				REMARKS
55	92990-05100	WASHER, SPRING	1				
56	655-44143-01	ROD, SHIFT	1				
57	92990-06200	WASHER, PLAIN	1				
58	91490-16010	PIN, COTTER	1				
59	616-44145-01	CONNECTOR, SHIFT ROD	1				
60	616-44146-01	CONNECTOR, SHIFT ROD	1				
61	97095-06020	BOLT	1				
62	92995-06600	WASHER	1				
63	90240-05004	PIN, CLEVIS	1				
64	6A1-83625-41	MARK 5	1				
65	6E0-83627-41	LABEL, CAUTION 7	1				

FIG. 12 REMO CON ATTACHMENT



6770200-9110

REF. NO.	PART NO.	DESCRIPTION	6804				REMARKS
1	655-48501-02	REMOTE CONT. ATTACHMENT ASSY.	1				AP ROPE TYPE
	655-48501-10	REMOTE CONT. ATTACHMENT ASSY.	1				AP BALL POST TYPE
2	655-48531-51	.BRACKET, REMOTE CONTROL 1	1				
3	97095-06018	.BOLT	2				
4	92995-06600	.WASHER	2				
5	647-48534-50	.THROTTLE LEVER, CONTROL	1				
6	97095-05020	.BOLT	1				
7	92995-05600	.WASHER	1				
8	97090-06045	.BOLT	1				
9	95380-06600	.NUT, HEXAGON	1				
10	647-48330-50	.CABLE END ASSY	1				
11	617-48346-90	..CABLE END, REMOTE CONTROL	1				
12	92990-08600	..WASHER, PLATE	1				
13	90501-10071	..SPRING, COMPRESSION	1				
14	617-48331-91	..HOOK, CABLE	1				
15	91690-30012	..PIN, SPRING	1				
16	647-48340-50	.CABLE END ASSY	1				
17	647-48346-50	..CABLE END, REMOTE CONTROL	1				
18	92990-08600	..WASHER, PLATE	1				
19	90501-10264	..SPRING, COMPRESSION	1				
20	617-48361-91	..HOOK, CABLE	1				
21	91690-30012	..PIN, SPRING	1				
22	700-48510-12	.STEERING HOOK ASSY	1				ROPE TYPE
23	676-48511-10	.HOOK, STEERING	1				BALL POST TYPE
24	97075-10040	.BOLT	1				
25	92990-10600	.WASHER, PLATE	1				
26	90185-10051	.NUT, SELF-LOCKING	1				

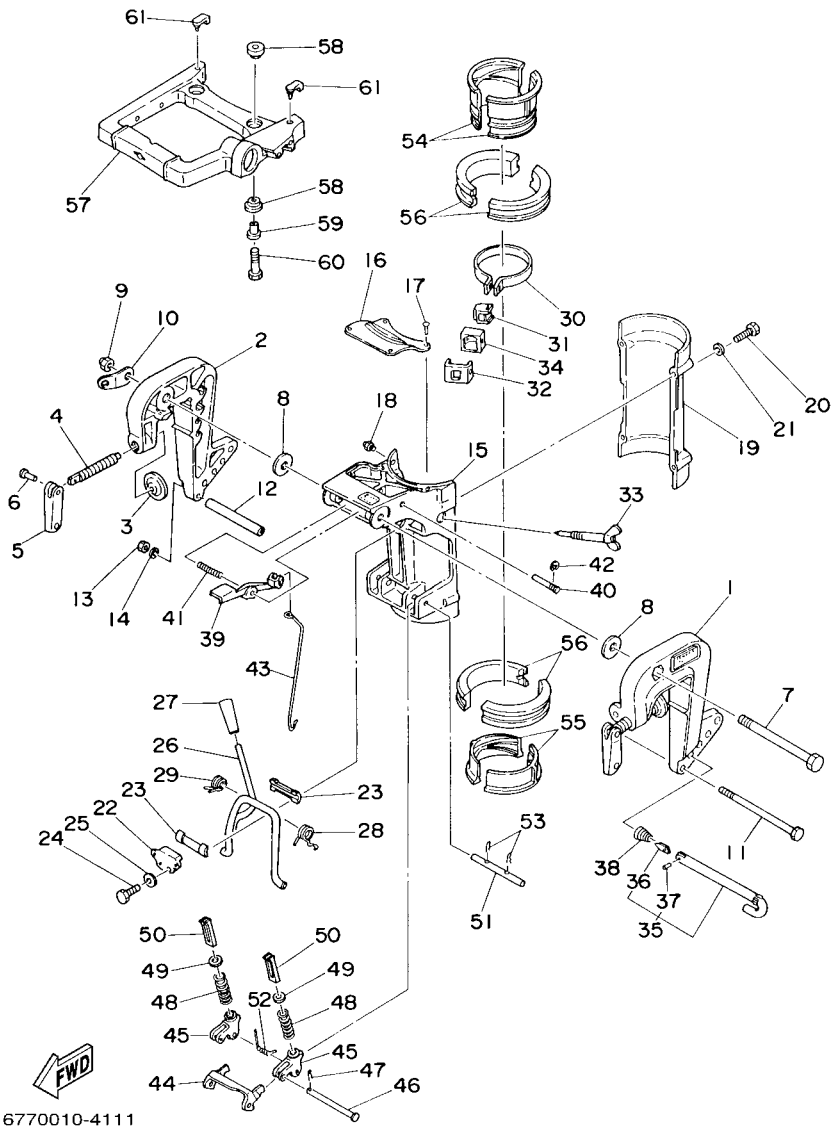

6770010-4111

FIG. 13 BRACKET

REF. NO.	PART NO.	DESCRIPTION	6804				REMARKS
1	620-43111-02-4D	BRACKET, CLAMP	1				
2	620-43112-01-4D	BRACKET, CLAMP	1				
3	620-43114-00	PAD, TRANSOM CLAMP	2				
4	677-43116-01	SCREW, TRANSOM CLAMP	2				
5	663-43118-01-4D	HANDLE, TRANSOM CLAMP	2				
6	90243-04007	PIN	2				
7	90101-10M00	BOLT	1				
8	90201-10M66	WASHER, PLATE	2				
9	90185-10051	NUT, SELF-LOCKING	1				
10	6E7-43113-01	PLATE, CLAMP BRACKET	1				
11	90101-06336	BOLT	1				
12	90387-06M11	COLLAR	1				
13	95380-06600	NUT, HEXAGON	1				
14	92990-06600	WASHER, PLATE	1				
15	677-43311-01-4D	BRACKET, SWIVEL 1	1				
16	655-43318-00-4D	COVER	1				
17	90269-02M08	RIVET	4				
18	93700-06M03	NIPPLE, GREASE	1				
19	647-43312-00-4D	BRACKET, SWIVEL 2	1				
20	97095-06040	BOLT	4				
21	92995-06600	WASHER	4				
22	654-43313-00-94	BRACKET, SWIVEL 3	1				
23	620-43189-00	BUSHING	2				
24	97095-06025	BOLT	2				
25	92995-06600	WASHER	2				
26	647-43181-00	LEVER, TILT STOP	1				
27	620-43632-00	KNOB, TILT	1				

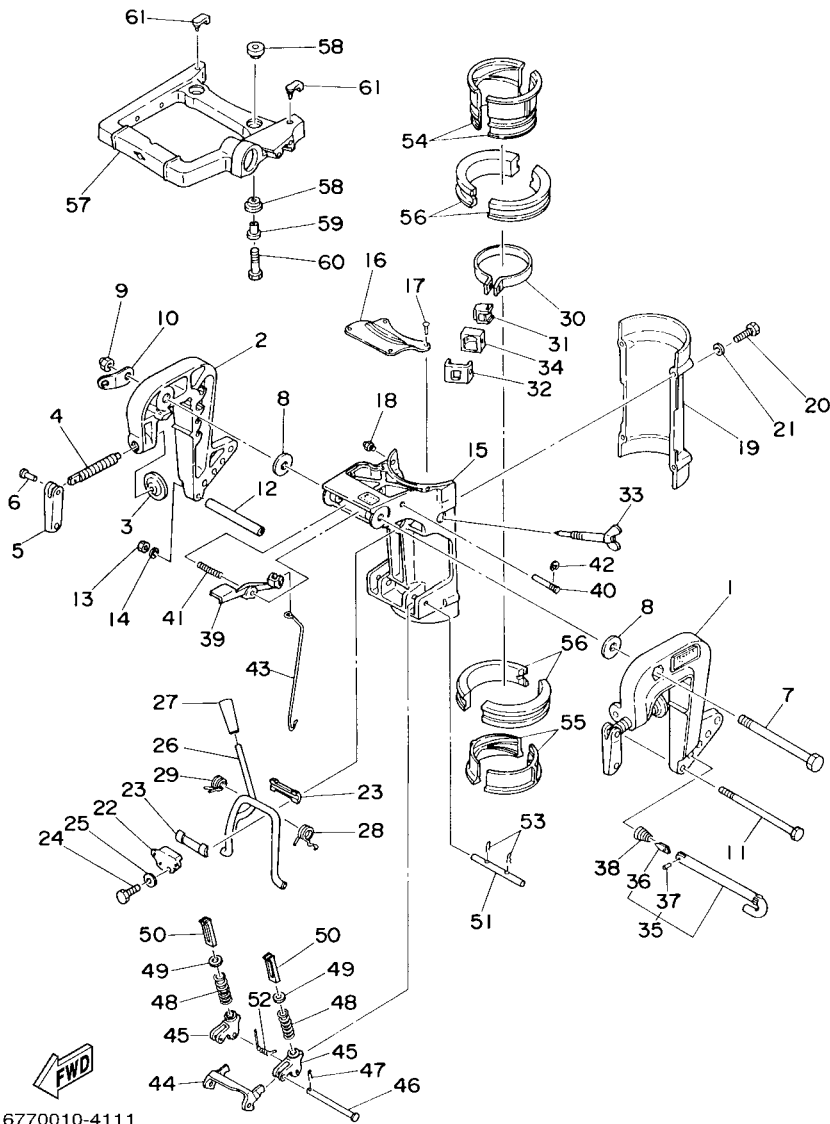

6770010-4111

FIG. 13 BRACKET

REF. NO.	PART NO.	DESCRIPTION	6804				REMARKS
28	90508-16021	SPRING, TORSION	1				
29	90508-16020	SPRING, TORSION	1				
30	655-42525-00	PLATE, FRICTION	1				
31	655-42526-00	PLATE, FRICTION	1				
32	655-42527-00	PLATE, FRICTION	1				
33	655-42529-00	SCREW, FRICTION PIECE	1				
34	655-42532-00	COVER	1				
35	6L4-43160-00	TILT ROD ASSY	1				
36	689-43165-00	.PLATE, TILT LOCK	1				
37	91690-30008	.PIN, SPRING	1				
38	90502-10M07	SPRING, CONICAL	1				
39	677-43630-00	TILT LEVER ASSY	1				
40	90249-04M05	PIN	1				
41	90501-16104	SPRING, COMPRESSION	1				
42	99001-04600	CIRCLIP	1				
43	677-43616-00	ROD, TILT LOCK	1				
44	647-43614-00	PLATE, TILT LOCK	1				
45	647-43615-01	PLATE, TILT LOCK	2				
46	90240-05047	PIN, CLEVIS	1				
47	90468-10005	CLIP	1				
48	90501-26147	SPRING, COMPRESSION	2				
49	647-43627-01	STOPPER	2				
50	647-43613-00	ARM, TILT LOCK	2				
51	647-43659-00	SHAFT, REVERSE LOCK	1				
52	90508-18022	SPRING, TORSION	1				
53	90468-10003	CLIP	2				
54	647-42537-00	BUSHING, PIVOT SHAFT	2				

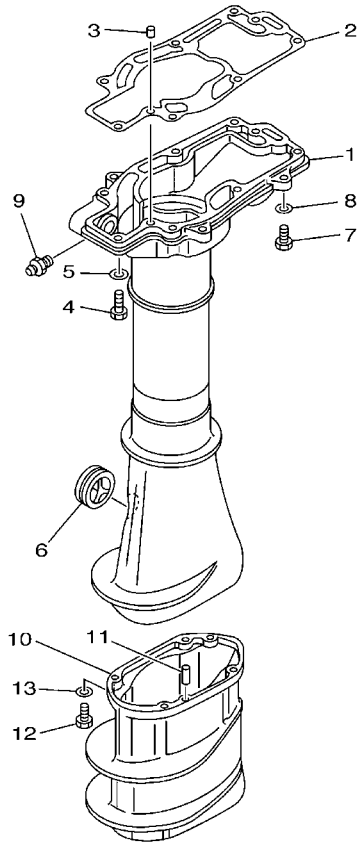

6801200-2140

FIG. 14 UPPER CASING

REF. NO.	PART NO.	DESCRIPTION	6804				REMARKS
1	677-45111-01-4D	CASING, UPPER	1				
2	677-45113-A1	GASKET, UPPER CASING	1				
3	93605-08041	PIN, DOWEL	2				
4	97095-06025	BOLT	7				
5	92995-06600	WASHER	7				
6	647-45151-01	COVER, UPPER CASING	1				
7	97095-06020	BOLT	4				
8	92995-06600	WASHER	4				
9	93700-06M03	NIPPLE, GREASE	1				
10	647-45211-10-4D	EXTENSION	1				L
11	93604-08062	PIN, DOWEL	2				L
12	97095-06020	BOLT	4				L
13	92995-06600	WASHER	4				L

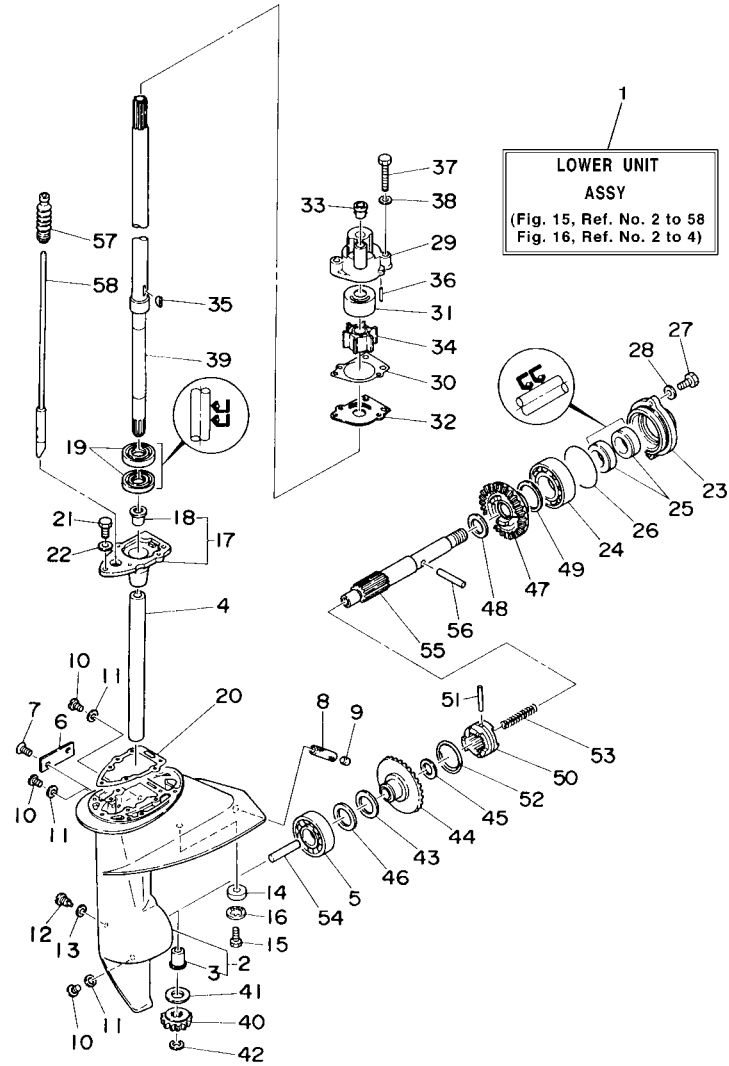

6801200-4150

FIG. 15 LOWER CASING & DRIVE 1

REF. NO.	PART NO.	DESCRIPTION	6804				REMARKS
1	677-45300-11-4D	LOWER UNIT ASSY	1				L
2	655-45310-02-4D	LOWER CASING ASSY	1				
3	647-45316-09	.BUSHING, DRIVE SHAFT	1				
4	90387-14108	COLLAR	1				
5	93306-004U0	BEARING	1				
6	655-45214-02-4D	COVER, WATER INLET	1				
7	90152-05M02	SCREW, COUNTERSUNK	2				
8	626-45215-00	COVER, WATER INLET	1				
9	90334-10008	PLUG, STRAIGHT	1				
10	90340-08002	PLUG, STRAIGHT SCREW	3				
11	90430-08020	GASKET	3				
12	90149-06003	SCREW	1				
13	90430-06M03	GASKET	1				
14	677-45251-00	ANODE	1				
15	95895-06012	BOLT, FLANGE	1				
16	92990-06300	WASHER, INTERNAL TOOTH	1				
17	647-45331-00-94	HOUSING, BEARING	1				
18	647-45316-09	.BUSHING, DRIVE SHAFT	1				
19	93101-18050	OIL SEAL	2				
20	677-45315-A1	PACKING, LOWER CASING	1				
21	97095-06020	BOLT	2				
22	92995-06600	WASHER	2				
23	655-45361-02-4D	CAP, LOWER CASING	1				
24	93306-00501	BEARING (B6005)	1				
25	93101-15074	OIL SEAL	2				
26	93210-58144	O-RING	1				
27	97095-06020	BOLT	2				

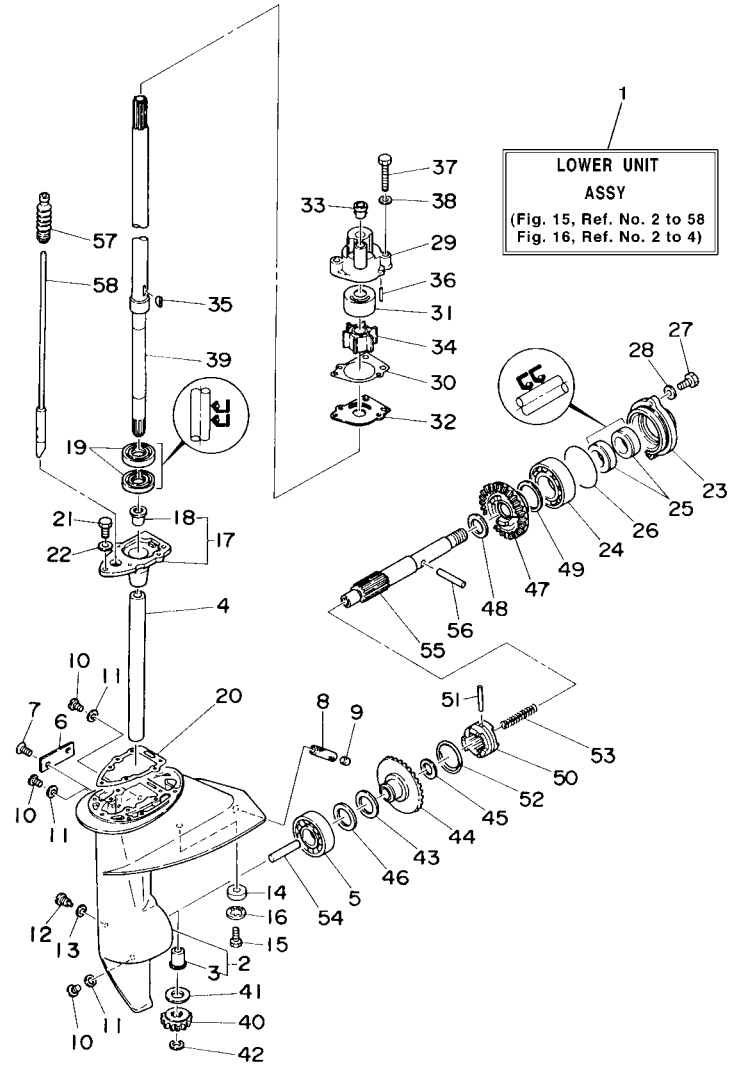

6801200-4150

FIG. 15 LOWER CASING & DRIVE 1

REF. NO.	PART NO.	DESCRIPTION	6804				REMARKS
28	92995-06600	WASHER	2				
29	655-44311-03	HOUSING, WATER PUMP	1				
30	655-44315-A1	GASKET, WATER PUMP	1				
31	650-44322-01	INSERT, CARTRIDGE	1				
32	655-44323-01	OUTER PLATE, CARTRIDGE	1				
33	647-44366-00	DAMPER, WATER SEAL	1				
34	662-44352-01	IMPELLER	1				
35	90280-03024	KEY, WOODRUFF	1				
36	93604-18080	PIN, DOWEL	2				
37	97095-06040	BOLT	3				
38	92995-06600	WASHER	3				
39	655-45501-10	DRIVE SHAFT COMP.	1				L
40	647-45551-00	PINION (13T)	1				
41	647-45533-00	SHIM (T:0.8MM)	1				UR
	647-45533-10	SHIM (T:0.9MM)	1				UR
	647-45533-20	SHIM (T:1.0MM)	1				UR
	647-45533-30	SHIM (T:1.1MM)	1				UR
	647-45533-40	SHIM (T:1.2MM)	1				UR
	647-45533-50	SHIM (T:1.3MM)	1				UR
	647-45533-60	SHIM (T:1.4MM)	1				UR
42	99001-07600	CIRCLIP	1				
43	90201-12161	WASHER, PLATE	1				
44	647-45560-00	GEAR 1 (27T)	1				
45	90201-13198	WASHER, PLATE	1				
46	647-45567-00	SHIM (T:0.10MM)	1				UN
47	647-45570-01	GEAR 2 (27T)	1				
48	90201-15229	WASHER, PLATE	1				

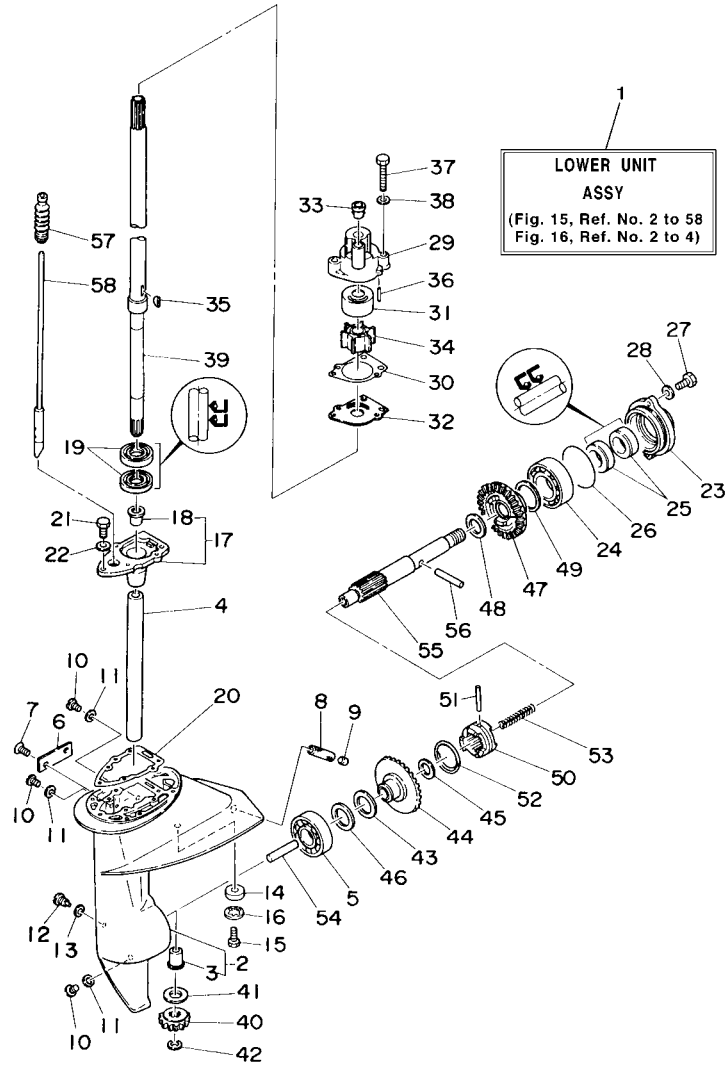

6801200-4150

FIG. 15 LOWER CASING & DRIVE 1

REF. NO.	PART NO.	DESCRIPTION	6804				REMARKS
49	626-45577-00	SHIM (T:0.10MM)	1				UR
	626-45577-10	SHIM (T:0.20MM)	1				UR
	626-45577-20	SHIM (T:0.30MM)	1				UR
	626-45577-30	SHIM (T:0.40MM)	1				UR
	626-45577-40	SHIM (T:0.50MM)	1				UR
50	655-45631-00	CLUTCH, DOG	1				
51	93605-29098	PIN, DOWEL	1				
52	93440-30040	CIRCLIP	1				
53	90501-12M61	SPRING, COMPRESSION	1				
54	654-45635-00	PLUNGER, SHIFT	1				
55	677-45611-01	SHAFT, PROPELLER	1				
56	90250-05036	PIN, STRAIGHT	1				
57	655-44147-00	BOOT, SHIFT ROD	1				
58	655-44150-10	SHIFT CAM ASSY	1				L

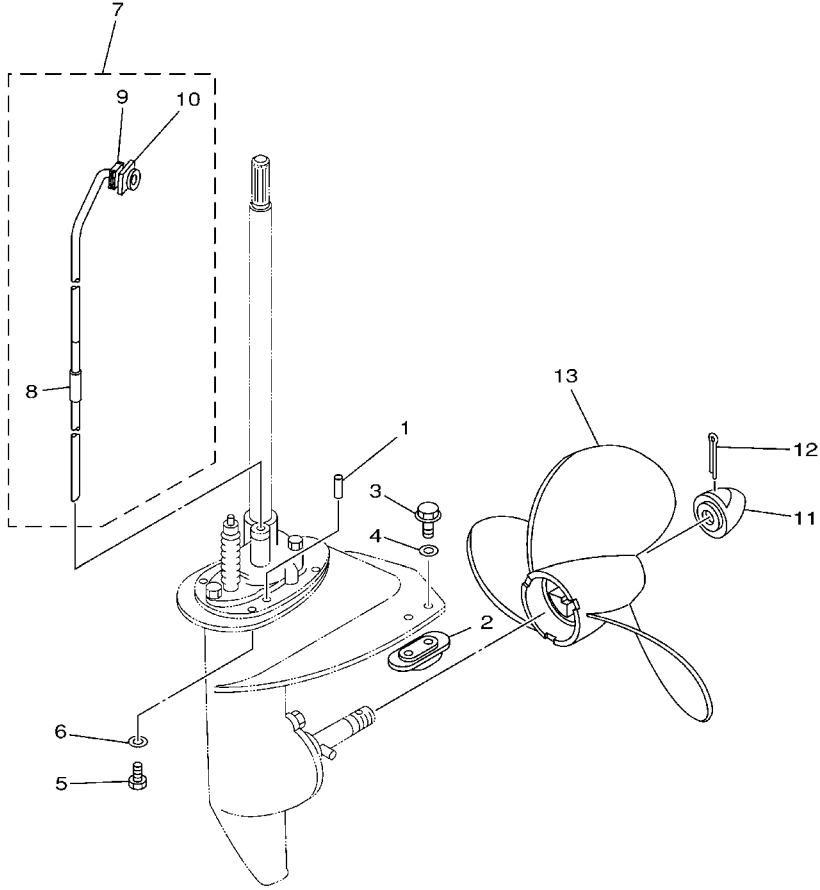

6770010-0140

FIG. 16 LOWER CASING & DRIVE 2

REF. NO.	PART NO.	DESCRIPTION	6804				REMARKS
1	93604-08062	PIN, DOWEL	2				
2	6E0-45251-12	ANODE	1				
3	95895-06016	BOLT, FLANGE	2				
4	92990-06300	WASHER, INTERNAL TOOTH	2				
5	97095-06020	BOLT	4				
6	92995-06600	WASHER	4				
7	655-44360-10	WATER TUBE ASSY	1				L
8	90445-11262	.HOSE (L30)	1				
9	655-44365-00	.DAMPER, WATER SEAL	1				
10	655-44373-00	.SET PLATE, WATER TUBE	1				
11	647-45616-02	NUT, PROPELLER	1				
12	91490-30030	PIN, COTTER	1				
13	647-45941-00-EL	PROPELLER (3X9-1/4"X9-1/4"-C)	1				UR
	647-45943-00-EL	PROPELLER (3X9"X7"-C)	1				UR
	647-45947-00-EL	PROPELLER (3X9"X9"-C)	1				UR
	655-45943-00-EL	PROPELLER (3X9"X7-1/2"-C)	1				UR
	655-45947-01-EL	PROPELLER (3X9"X5-3/4"-C)	1				UR
	655-45949-00-EL	PROPELLER (3X9"X5"-C)	1				UR

E1

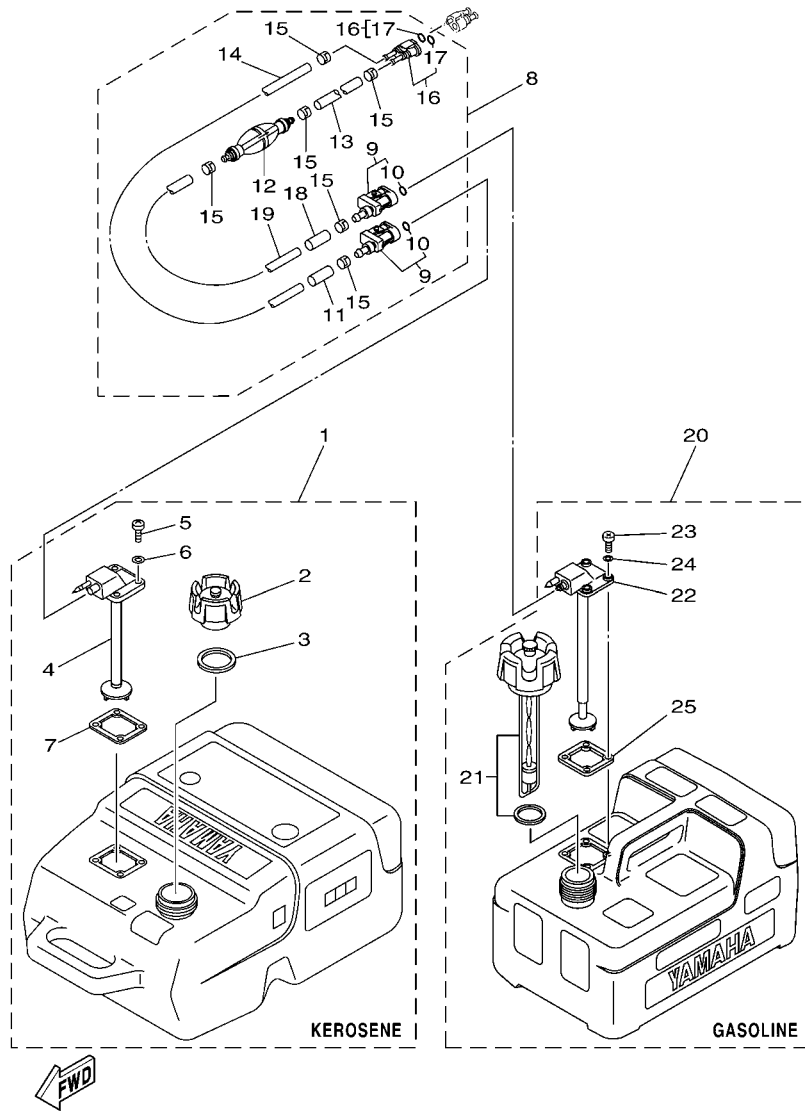

69T5200-D190

FIG. 17 FUEL TANK

REF. NO.	PART NO.	DESCRIPTION	6804				REMARKS
1	6YK-24201-20	FUEL TANK ASSY (25L,KEROSENE)	1				AP KEROSENE
2	6YK-24610-10	.CAP ASSY	1				WITHOUT INDICATOR
3	6YL-24641-00	.GASKET, CAP 1	1				
4	6YK-24260-01	.FUEL METER ASSY	1				
5	90157-05M16	.SCREW, PAN HEAD	4				
6	6YL-24329-00	.SEAL	4				
7	6YL-24268-01	.GASKET, FUEL METER	1				
8	6YK-24306-03	FUEL PIPE COMP. 1	1				AP
9	6Y1-24305-05	.FUEL PIPE JOINT COMP. 2	2				
10	93210-08287	..O-RING	1				
11	6Y1-24397-10	.COLLAR (KEROSENE)	1				
12	61J-24360-00	.PRIMER PUMP ASSY	1				
13	90445-11M05	.HOSE (L850)	1				
14	90445-11M81	.HOSE (L3000)	1				
15	650-24351-01	.BAND 1	6				
16	680-24305-01	.FUEL PIPE JOINT COMP. 2	1				
17	93210-08287	..O-RING	2				
18	6Y1-24397-00	.COLLAR (GASOLINE)	1				
19	90445-11M06	.HOSE (L2050)	1				
20	6YL-24201-04	FUEL TANK ASSY (12L)	1				AP GASOLINE
21	6YL-24610-01	.CAP ASSY	1				
22	6YL-24260-01	.FUEL METER ASSY	1				
23	90157-05M16	.SCREW, PAN HEAD	4				
24	6YL-24329-00	.SEAL	4				
25	6YL-24268-01	.GASKET, FUEL METER	1				

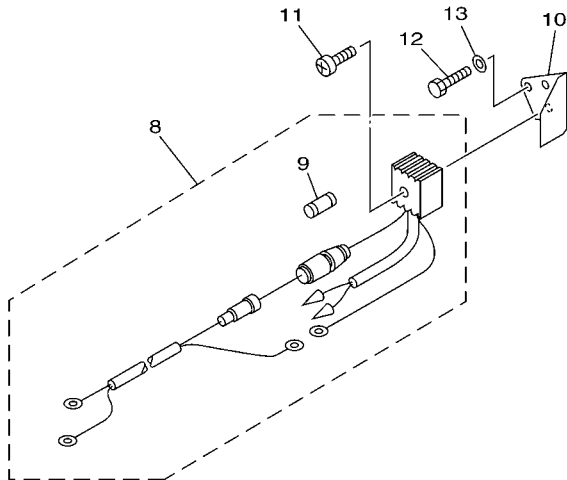
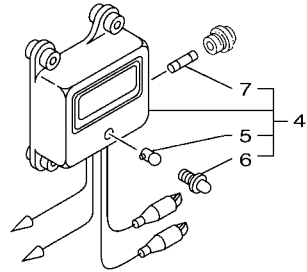
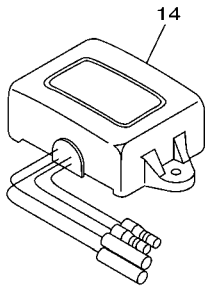
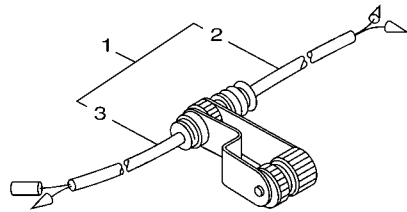

6804200-D180

FIG. 18 OPTIONAL PARTS

REF. NO.	PART NO.	DESCRIPTION	6804				REMARKS
1	682-84380-00	CONCENT 2P	1				
2	682-84381-00	.2P CONCENT	1				
3	682-84382-00	.2P CONCENT	1				
4	648-81970-41	RECTIFIER ASSY	1				
5	648-81977-40	.BULB, PILOT LIGHT	1				
6	648-81978-40	.LENS, PILOT LIGHT	1				
7	648-82151-41	.FUSE	1				
8	676-81970-00	RECTIFIER ASSY	1				
9	663-82151-00	.FUSE (12V-20A)	1				
10	677-81975-00	PLATE, RECTIFIER FITTING	1				
11	97880-05025	SCREW, PAN HEAD	1				
12	97013-06010	BOLT	2				
13	92903-06600	WASHER, PLATE	2				
14	663-81910-10	VOLTAGE REGULATOR ASSY	1				

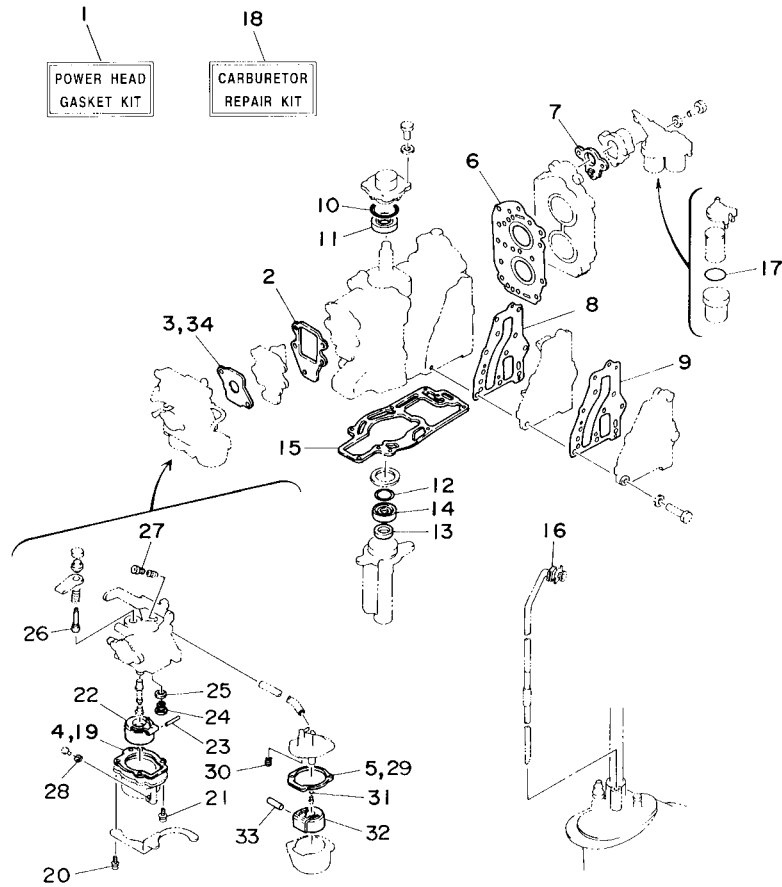

6802200-3190

FIG. 19 REPAIR KIT 1

REF. NO.	PART NO.	DESCRIPTION	6804				REMARKS
1	680-W0001-A2	POWER HEAD GASKET KIT	1				
2	677-13621-A1	.GASKET, VALVE SEAT	1				
3	650-14198-A1	.GASKET	1				
4	650-14384-00	.GASKET, FLOAT CHAMBER	1				
5	652-14384-00	.GASKET, FLOAT CHAMBER	1				
6	677-11181-A1	.GASKET, CYLINDER HEAD 1	1				
7	677-12414-A1	.GASKET, COVER	1				
8	677-41112-A1	.GASKET, EXHAUST INNER COVER	1				
9	677-41114-A1	.GASKET, EXHAUST OUTER COVER	1				
10	93210-42159	.O-RING	1				
11	93102-20M25	.OIL SEAL	1				
12	93210-42M70	.O-RING	1				
13	93101-14M01	.OIL SEAL	1				
14	93101-20M29	.OIL SEAL	1				
15	677-45113-A1	.GASKET, UPPER CASING	1				
16	655-44365-00	.DAMPER, WATER SEAL	1				
17	93210-32738	.O-RING	1				
18	680-W0093-01	CARBURETOR REPAIR KIT	1				
19	650-14384-00	.GASKET, FLOAT CHAMBER	1				
20	97980-04115	.SCREW, WITH WASHER	4				
21	97980-04112	.SCREW, WITH WASHER	2				
22	647-14385-00	.FLOAT	1				
23	626-14386-00	.PIN, FLOAT	1				
24	677-14390-12	.NEEDLE VALVE ASSY	1				
25	626-14398-00	.GASKET	1				
26	626-14371-00	.PLUNGER, STARTER	1				
27	647-14323-00	.SCREW, AIR ADJUSTING	1				

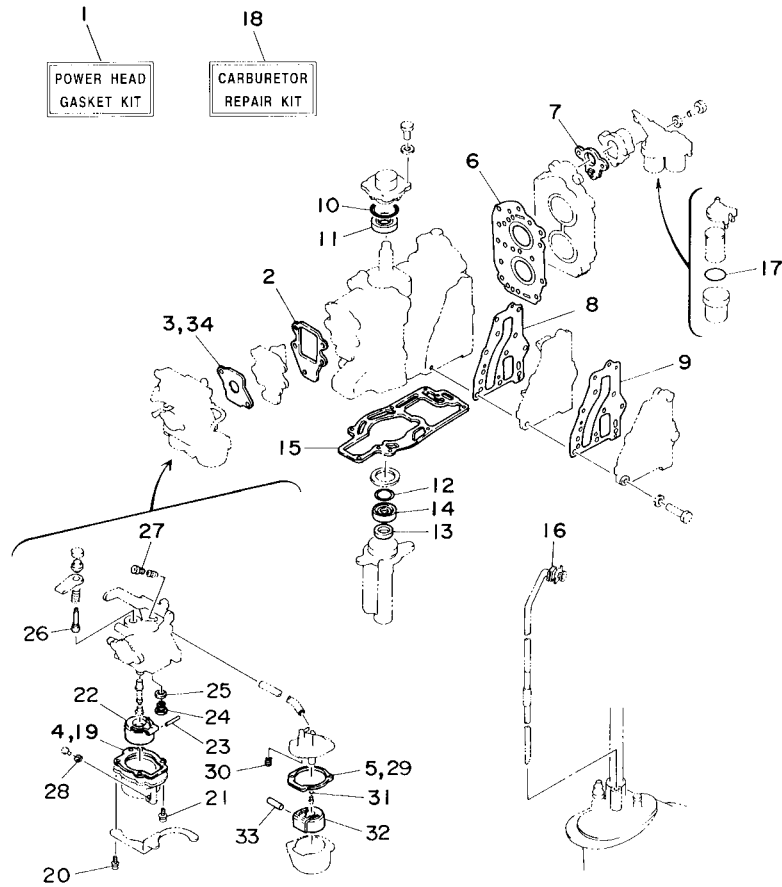

6802200-3190

FIG. 19 REPAIR KIT 1

REF. NO.	PART NO.	DESCRIPTION	6804				REMARKS
28	6L2-14398-00	.GASKET	2				
29	652-14384-00	.GASKET, FLOAT CHAMBER	1				
30	6F5-14392-00	.VALVE, NEEDLE	1				
31	652-14147-00	.O-RING	1				
32	652-14385-00	.FLOAT	1				
33	652-14386-00	.PIN, FLOAT	1				
34	650-14198-A1	.GASKET	1				

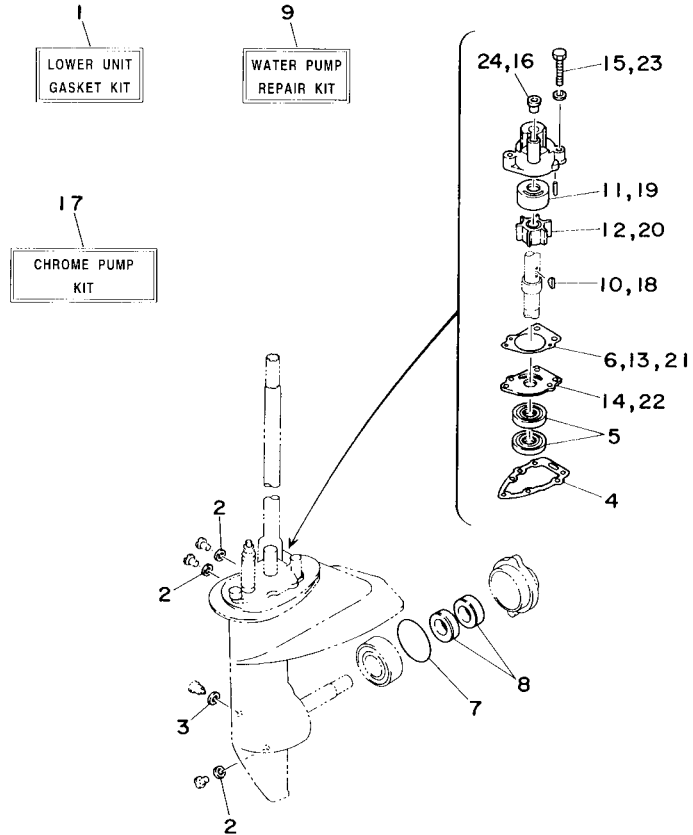

FWD
6801200-4200

FIG. 20 REPAIR KIT 2

REF. NO.	PART NO.	DESCRIPTION	6804				REMARKS
1	677-W0001-C0	LOWER UNIT GASKET KIT	1				
2	90430-08020	.GASKET	3				
3	90430-06M03	.GASKET	1				
4	677-45315-A1	.PACKING, LOWER CASING	1				
5	93101-18050	.OIL SEAL	2				
6	655-44315-A1	.GASKET, WATER PUMP	1				
7	93210-58144	.O-RING	1				
8	93101-15074	.OIL SEAL	2				
9	655-W0078-B0	WATER PUMP REPAIR KIT	1				
10	90280-03024	.KEY, WOODRUFF	1				
11	650-44322-01	.INSERT, CARTRIDGE	1				
12	662-44352-01	.IMPELLER	1				
13	655-44315-A1	.GASKET, WATER PUMP	1				
14	655-44323-01	.OUTER PLATE, CARTRIDGE	1				
15	97095-06040	.BOLT	3				
16	647-44366-00	.DAMPER, WATER SEAL	1				
17	655-W0078-CA	CHROMATE POMP KIT	1				
18	90280-03024	.KEY, WOODRUFF	1				
19	655-44322-41	.INSERT, CARTRIDGE	1				
20	662-44352-01	.IMPELLER	1				
21	655-44315-A1	.GASKET, WATER PUMP	1				
22	655-44323-41	.OUTER PLATE, CARTRIDGE	1				
23	97095-06040	.BOLT	3				
24	647-44366-00	.DAMPER, WATER SEAL	1				

NUMERICAL INDEX

PART NO.	REF. NO.	PART NO.	REF. NO.	PART NO.	REF. NO.	PART NO.	REF. NO.	PART NO.	REF. NO.	PART NO.	REF. NO.
680-11111-00-1S	2 - 30	680-14341-00	5 - 6	677-15710-05-94	8 - 1	652-24432-00	6 - 18	647-42177-00	11 - 15	620-43632-00	13 - 27
677-11181-A1	2 - 31	648-14342-24	5 - 30	682-15711-71-94	8 - 2	648-24434-01	6 - 19	655-42511-00-4D	13 - 57	647-43659-00	13 - 51
	19 - 6	647-14342-55	5 - 49	677-15714-00-94	8 - 4	648-24435-02	6 - 27	647-42523-00	13 - 61	655-44111-02-4D	11 - 45
664-11325-00	2 - 15	648-14343-34	5 - 7	677-15717-01	8 - 10	62C-24461-00	6 - 12	655-42525-00	13 - 30	677-44119-00	11 - 51
650-11370-01	2 - 3	648-14344-35	5 - 29	6E7-15723-00-94	8 - 29	652-24461-00	6 - 11	655-42526-00	13 - 31	655-44121-01	11 - 53
676-11372-00	2 - 5	680-14346-00	5 - 48	677-15741-01	8 - 11	6A4-24471-00	6 - 17	655-42527-00	13 - 32	655-44122-03	11 - 47
677-11372-00	2 - 4	652-14348-00	5 - 46	677-15746-00	8 - 37	652-24471-10	6 - 13	655-42529-00	13 - 33	655-44143-01	11 - 56
680-11400-02	3 - 1	680-14348-00	5 - 47	677-15747-00	8 - 40	61N-24521-00	6 - 6	655-42532-00	13 - 34	616-44145-01	11 - 59
677-11412-02	3 - 2	650-14349-00	5 - 19	656-15748-00	8 - 33	61N-24560-00	6 - 4	647-42537-00	13 - 54	616-44146-01	11 - 60
677-11422-02	3 - 3	652-14353-25	5 - 41	689-15755-01	8 - 14	61N-24563-00	6 - 5	677-42538-00	13 - 55	655-44147-00	15 - 57
677-11432-02	3 - 4	626-14371-00	5 - 28	677-15758-01-94	8 - 18	680-24566-01	6 - 8	647-42539-00	13 - 56	655-44150-10	15 - 58
677-11442-02	3 - 5		19 - 26	677-15761-01	1 - 2	6YL-24610-01	17 - 21	647-42541-00	13 - 58	655-44311-03	15 - 29
677-11515-01	3 - 11	626-14373-00	5 - 24	677-15762-00	8 - 19	6YK-24610-10	17 - 2	655-42542-00	13 - 59	655-44315-A1	15 - 30
647-11610-00	3 - 15	626-14374-00	5 - 25	677-15770-01	8 - 35	6YL-24641-00	17 - 3	606-42591-00	1 - 21		20 - 6
647-11610-10	3 - 15	626-14376-00	5 - 23	6K3-15771-00-94	8 - 26	677-26301-02	11 - 22	680-42610-L1-4D	1 - 1	650-44322-01	15 - 31
647-11610-20	3 - 15	626-14378-00	5 - 26	677-15772-00	8 - 36	626-28193-01-94	6 - 44	6G1-42615-00	1 - 3		20 - 11
677-11631-00-97	3 - 14	680-14381-20	5 - 2	648-15773-00	8 - 3	677-41111-01-1S	2 - 38	677-42647-00	1 - 4	655-44322-41	20 - 19
6G1-11633-00	3 - 16	650-14384-00	5 - 3	6F5-15779-02	8 - 16	677-41112-A1	2 - 39	677-42651-02	1 - 5	655-44323-01	15 - 32
677-11635-00	3 - 14		19 - 4	6A0-15789-00	8 - 17		19 - 8	626-42658-00	5 - 14		20 - 14
677-11636-00	3 - 14	652-14384-00	5 - 39	6YL-24201-04	17 - 20	677-41113-01-1S	2 - 41	677-42677-J0	1 - 7	655-44323-41	20 - 22
680-11651-02	3 - 6		19 - 5	6YK-24201-20	17 - 1	677-41114-A1	2 - 40	680-42678-K0	1 - 8	662-44352-01	15 - 34
6G1-11681-00	3 - 8	647-14385-00	5 - 8	6YK-24260-01	17 - 4		19 - 9	680-42711-70-4D	1 - 11		20 - 12
6E5-12411-02	2 - 34		19 - 22	6YL-24260-01	17 - 22	680-41201-00	4 - 20	655-42715-00	11 - 48	655-44360-10	16 - 7
677-12413-00-1S	2 - 33	652-14385-00	5 - 43	6YL-24268-01	17 - 7	680-41213-00-94	9 - 25	677-42724-00	1 - 19	655-44365-00	16 - 9
677-12414-A1	2 - 35		19 - 32	680-24304-01	6 - 1	680-41216-00	5 - 13	677-42725-00	1 - 20		19 - 16
	19 - 7	626-14386-00	5 - 10	680-24305-01	7 - 6	677-41226-00	5 - 17	669-42791-00	1 - 25	647-44366-00	15 - 33
6B8-13437-00	1 - 10		19 - 23		17 - 16	680-41241-00	5 - 22	677-42815-00-4D	1 - 12		20 - 16
680-13610-00	4 - 1	652-14386-00	5 - 45	6Y1-24305-05	17 - 9	680-41256-00	4 - 10	656-42816-00	1 - 15	655-44373-00	16 - 10
677-13621-A1	4 - 3		19 - 33	6YK-24306-03	17 - 8	680-41257-00	4 - 16	620-43111-02-4D	13 - 1	677-45111-01-4D	14 - 1
	19 - 2	652-14387-40	5 - 44	6Y3-24306-04	7 - 1	661-41262-02	4 - 19	620-43112-01-4D	13 - 2	677-45113-A1	14 - 2
652-14147-00	5 - 42	626-14387-90	5 - 9	680-24311-00	6 - 37	677-41271-00	4 - 11	6E7-43113-01	13 - 10		19 - 15
	19 - 31	677-14390-12	5 - 11	6YL-24329-00	17 - 6	677-41611-00-94	9 - 18	620-43114-00	13 - 3	647-45151-01	14 - 6
680-14181-00	5 - 37		19 - 24	650-24351-01	7 - 5	677-41612-00	9 - 19	677-43116-01	13 - 4	647-45211-10-4D	14 - 10
680-14182-00	5 - 38	6F5-14392-00	5 - 40		17 - 15	680-41615-10	9 - 22	663-43118-01-4D	13 - 5	655-45214-02-4D	15 - 6
650-14198-A1	4 - 7		19 - 30		7 - 3	677-41631-00	11 - 36	6L4-43160-00	13 - 35	626-45215-00	15 - 8
	19 - 3	626-14398-00	5 - 12	61J-24360-00	17 - 12	677-41632-00	11 - 40	689-43165-00	13 - 36	677-45251-00	15 - 14
646-14212-01	5 - 32		19 - 25	6Y1-24397-00	17 - 18	655-41635-00	11 - 32	647-43181-00	13 - 26	6E0-45251-12	16 - 2
680-14301-02	5 - 1	6L2-14398-00	5 - 36	6Y1-24397-10	17 - 11	655-41638-01	11 - 31	620-43189-00	13 - 23	677-45300-11-4D	15 - 1
680-14315-00	5 - 20		19 - 28	6A4-24410-06	6 - 10	650-41641-00	11 - 33	677-43311-01-4D	13 - 15	655-45310-02-4D	15 - 2
650-14321-01	5 - 33	680-14431-00	4 - 22	648-24411-00	6 - 20	647-41652-00	8 - 43	647-43312-00-4D	13 - 19	677-45315-A1	15 - 20
647-14323-00	5 - 31	680-14441-00	4 - 23	663-24411-00	6 - 26		11 - 41	654-43313-00-94	13 - 22		20 - 4
	19 - 27	624-14485-00	2 - 6	6A0-24412-02	6 - 31	677-41661-00-94	11 - 26	655-43318-00-4D	13 - 16	647-45316-09	15 - 3
6A0-14325-00	6 - 24	655-14497-01	11 - 30	6A0-24413-00	6 - 28	647-42111-02-4D	11 - 1	647-43613-00	13 - 50	647-45331-00-94	15 - 17
650-14327-01	5 - 18	680-15100-03-1S	2 - 2	652-24415-01	6 - 14	677-42112-00-4D	11 - 9	647-43614-00	13 - 44	655-45361-02-4D	15 - 23
677-14327-01	5 - 16	677-15359-00-94	2 - 17	6A0-24421-01	6 - 23	647-42119-02	11 - 14	647-43615-01	13 - 45	655-45501-10	15 - 39
648-14331-00	5 - 21	680-15379-01	2 - 29	648-24423-00	6 - 22	656-42126-01	11 - 18	677-43616-00	13 - 43	647-45533-00	15 - 41
626-14333-00	5 - 34	677-15396-01-5B	2 - 22	648-24424-00	6 - 21	680-42137-00	11 - 16	647-43627-01	13 - 49	647-45533-10	15 - 41
626-14335-00	5 - 27	677-15705-02	8 - 13	650-24431-A0	6 - 32	655-42138-01	11 - 21	677-43630-00	13 - 39	647-45533-20	15 - 41

NUMERICAL INDEX

PART NO.	REF. NO.	PART NO.	REF. NO.	PART NO.	REF. NO.	PART NO.	REF. NO.	PART NO.	REF. NO.	PART NO.	REF. NO.
647-45533-30	15 - 41	6K3-83557-00	10 - 13	90170-10113	9 - 16	90445-11262	16 - 8	92990-03600	4 - 17	93210-42159	19 - 10
647-45533-40	15 - 41	6A1-83625-41	11 - 64	90179-06045	11 - 23	90445-11M05	7 - 4	92990-04500	6 - 16	93210-42M70	2 - 23
647-45533-50	15 - 41	6E0-83627-41	11 - 65	90185-06062	11 - 8		17 - 13	92990-04600	4 - 14		19 - 12
647-45533-60	15 - 41	682-84380-00	18 - 1	90185-10051	12 - 26	90445-11M06	7 - 2	92990-05100	6 - 30	93210-58144	15 - 26
647-45551-00	15 - 40	682-84381-00	18 - 2		13 - 9		17 - 19		11 - 55		20 - 7
647-45560-00	15 - 44	682-84382-00	18 - 3	90201-06060	8 - 8	90445-11M81	7 - 8	92990-05200	11 - 43	93306-004U0	15 - 5
647-45567-00	15 - 46	6K3-85509-70	9 - 3	90201-06068	1 - 16		17 - 14	92990-05600	4 - 25	93306-00501	15 - 24
647-45570-01	15 - 47	6G1-85515-70	9 - 14	90201-10120	8 - 32	90467-06016	2 - 11	92990-06100	11 - 38	93306-204U0	3 - 9
626-45577-00	15 - 49	6E7-85520-70	9 - 4	90201-10126	9 - 17	90467-08004	6 - 38	92990-06200	11 - 57	93310-418U1	3 - 7
626-45577-10	15 - 49	6E7-85533-40	9 - 6	90201-10M66	13 - 8	90467-09M03	6 - 42	92990-06300	15 - 16	93430-04301	5 - 15
626-45577-20	15 - 49	680-85540-01	10 - 1	90201-12161	15 - 43	90467-09M09	2 - 13		16 - 4	93430-06M02	8 - 12
626-45577-30	15 - 49	680-85542-00	10 - 7	90201-12565	3 - 18	90468-10003	13 - 53	92990-06600	11 - 37	93440-30040	15 - 52
626-45577-40	15 - 49	6G1-85548-70	9 - 11	90201-13198	15 - 45	90468-10004	4 - 13		13 - 14	93440-47055	3 - 13
677-45611-01	15 - 55	6G1-85550-71	9 - 1	90201-15229	15 - 48	90468-10005	8 - 41	92990-08600	12 - 12	93450-13022	3 - 19
647-45616-02	16 - 11	6K3-85560-40	9 - 2	90201-41303	2 - 26		11 - 44	92990-10600	12 - 25	93505-16024	11 - 49
655-45631-00	15 - 50	680-85570-00	10 - 3	90202-05088	8 - 42		13 - 47	92995-05600	9 - 21	93602-14118	3 - 17
654-45635-00	15 - 54	6E7-85580-70	9 - 5	90206-05005	11 - 42	90480-14M02	4 - 12		12 - 7	93604-08062	14 - 11
647-45941-00-EL	16 - 13	680-W0001-A2	19 - 1	90206-12052	1 - 13	90480-16M03	11 - 25	92995-06100	10 - 5		16 - 1
647-45943-00-EL	16 - 13	677-W0001-C0	20 - 1	90209-18112	3 - 10	90480-25161	10 - 14	92995-06600	1 - 18	93604-18080	15 - 36
655-45943-00-EL	16 - 13	680-W0004-00	4 - 2	90240-05004	11 - 63	90480-25M18	10 - 15		2 - 21	93605-08041	2 - 7
647-45947-00-EL	16 - 13	677-W0070-H0	1 - 9	90240-05047	13 - 46	90501-10071	12 - 13		4 - 9		14 - 3
655-45947-01-EL	16 - 13	655-W0078-B0	20 - 9	90243-04007	13 - 6	90501-10227	8 - 34		6 - 3	93605-29098	15 - 51
655-45949-00-EL	16 - 13	655-W0078-CA	20 - 17	90249-04M05	13 - 40	90501-10264	12 - 19		8 - 21	93700-06M03	13 - 18
647-48330-50	12 - 10	680-W0090-65-1S	2 - 1	90250-05036	15 - 56	90501-12274	11 - 50		9 - 24		14 - 9
617-48331-91	12 - 14	680-W0093-01	19 - 18	90254-03003	11 - 35	90501-12M61	15 - 53		10 - 6	94702-00039	2 - 44
647-48340-50	12 - 16	656-W2810-02	6 - 43	90266-04M04	1 - 6	90501-16104	13 - 41		11 - 11	95303-06600	8 - 9
647-48346-50	12 - 17	90101-06336	13 - 11	90269-02M08	13 - 17	90501-23215	11 - 17		12 - 4	95380-03600	6 - 25
617-48346-90	12 - 11	90101-10M00	13 - 7	90280-03024	15 - 35	90501-26147	13 - 48		13 - 21	95380-04700	4 - 15
617-48361-91	12 - 20	90116-06123	4 - 27		20 - 10	90502-10M07	13 - 38		14 - 5	95380-06600	11 - 39
655-48501-02	12 - 1	90119-06023	2 - 43	90280-04M06	9 - 15	90508-16020	13 - 29		15 - 22		12 - 9
655-48501-10	12 - 1	90119-06047	2 - 37	90334-10008	15 - 9	90508-16021	13 - 28		16 - 6		13 - 13
700-48510-12	12 - 22	90119-06048	2 - 32	90340-08002	15 - 10	90508-18022	13 - 52		2 - 25	95380-06700	4 - 8
676-48511-10	12 - 23	90119-06M15	2 - 8	90386-08032	11 - 6	90510-08M04	8 - 6	93101-14M01	19 - 13	95380-08600	6 - 9
655-48531-51	12 - 2	90119-06M16	2 - 9	90386-12069	1 - 14	90560-12075	11 - 2	93101-15074	15 - 25	95895-06012	15 - 15
647-48534-50	12 - 5	90119-06M20	10 - 2	90387-05M09	4 - 26	90560-12141	11 - 4		20 - 8	95895-06016	16 - 3
655-48541-00-4D	11 - 34	90119-06M34	8 - 7	90387-06504	8 - 38	90560-30085	11 - 3	93101-18050	15 - 19	97013-06010	18 - 12
663-81910-10	18 - 14	90119-06M69	4 - 6	90387-06M11	13 - 12	91490-16010	11 - 58		20 - 5	97013-06018	4 - 4
676-81970-00	18 - 8	90119-06M87	8 - 39	90387-14108	15 - 4	91490-30030	16 - 12	93101-20M29	2 - 24	97075-08035	13 - 60
648-81970-41	18 - 4	90119-06MA3	2 - 36	90430-06M03	15 - 13	91690-30008	13 - 37		19 - 14	97075-10040	12 - 24
677-81975-00	18 - 10	90119-06MA4	2 - 42		20 - 3	91690-30010	3 - 12	93102-20M25	2 - 19	97090-05020	11 - 54
648-81977-40	18 - 5	90149-05M13	11 - 19	90430-08020	15 - 11	91690-30012	12 - 15		19 - 11	97090-06045	12 - 8
648-81978-40	18 - 6	90149-06003	15 - 12		20 - 2	91690-40016	11 - 46	93210-08287	7 - 7	97095-05014	9 - 26
663-82151-00	18 - 9	90151-06M01	2 - 16	90445-07M02	2 - 10	91690-40020	8 - 5		17 - 10	97095-05020	12 - 6
648-82151-41	18 - 7	90152-05M02	15 - 7	90445-09M25	6 - 36	92902-04100	9 - 13	93210-09165	11 - 52	97095-06012	1 - 17
682-82370-00	10 - 12	90157-05M16	17 - 5	90445-10M03	2 - 12	92902-05100	9 - 9	93210-25032	11 - 5		4 - 21
682-82556-00	1 - 23	90159-05038	9 - 10	90445-10M40	6 - 40	92903-06600	4 - 5	93210-32738	6 - 7		8 - 30
677-82575-20	1 - 22	90159-05039	9 - 7	90445-10M41	6 - 41		18 - 13		19 - 17	97095-06014	10 - 8
689-8257Y-00	1 - 24	90170-06011	11 - 24	90445-10M92	6 - 39	92903-10600	11 - 20	93210-42159	2 - 18	97095-06016	2 - 27



NUMERICAL INDEX

PART NO.	REF. NO.	PART NO.	REF. NO.	PART NO.	REF. NO.	PART NO.	REF. NO.	PART NO.	REF. NO.	PART NO.	REF. NO.
97095-06016	8 - 20										
	9 - 23										
97095-06018	2 - 20										
	8 - 27										
	12 - 3										
97095-06020	6 - 2										
	8 - 22										
	11 - 7										
	14 - 7										
	15 - 21										
	16 - 5										
97095-06025	10 - 4										
	13 - 24										
	14 - 4										
97095-06035	8 - 24										
	11 - 28										
97095-06040	11 - 12										
	13 - 20										
	15 - 37										
	20 - 15										
97095-06045	6 - 34										
97595-06550	6 - 33										
97802-04008	9 - 12										
97802-05020	9 - 8										
97880-05025	4 - 24										
	18 - 11										
97885-05010	9 - 20										
97890-04005	5 - 35										
97980-04112	5 - 4										
	19 - 21										
97980-04115	5 - 5										
	19 - 20										
98503-05028	6 - 29										
98780-04010	6 - 15										
99001-04600	13 - 42										
99001-07600	15 - 42										
99530-10014	2 - 14										

EK8DMH
PARTS CATALOGUE
©2004 by Yamaha Motor Co., Ltd.
1st edition, June 2004
All rights reserved.
Any reprinting or unauthorized use
without the written permission of
Yamaha Motor Co., Ltd.
is expressly prohibited.
Printed in Japan.